

# PIN PONG

## Operation and Maintenance Manual

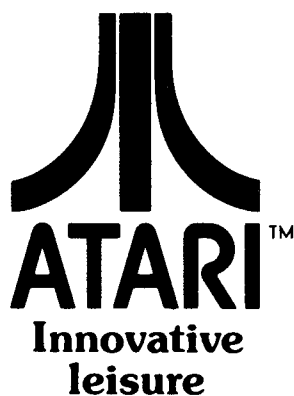

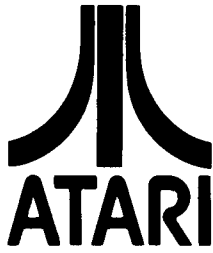

Job Title P.C. BOARD ASSEMBLY  
PIN PONG - 60 HZ

Dwg. P/L 001660-01

Parts List Specification

sheet 1 of 2

Drawn Cynthia  
Checked  
Proj. Eng. Larry Expert  
Mech. Eng. [Signature]  
Elec. Eng. Larry Expert  
Rev. 5

Rev.	Description	Apprv.	Rev.	Description	Apprv.
C	PROD. REL	[Signature]			
D	REV PER ECN 751,811,812	[Signature]			
E	Rev per ECN 926	[Signature]			
F	Rev per ECN 971	[Signature]			
G	REV PER ECN 1071	[Signature]			

Item	Part. No.	Qty.	Description
1	72062/37-74L00	1	Integrated Circuit, 74L00
2	72000/37-7400	8	" " 7400
3	72001/37-7402	7	" " 7402
4	72002/37-7404	5	" " 7404
5	72027/37-7408	8	" " 7408
6	72003/37-7410	7	" " 7410
7	72061/37-7414	1	" " 7414
8	72004/37-7420	5	" " 7420
9	72006/37-7427	2	" " 7427
10	72007/37-7430	2	" " 7430
11	72064/37-7432	1	" " 7432
12	72008/37-7448	1	" " 7448
13	72010/37-7474	20	" " 7474
14	72059/37-7485	2	" " 7485
15	72012/37-7486	8	" " 7486
16	72013/37-7490	4	" " 7490
17	72014/37-7493	3	" " 7493
18	72015/37-74107	4	" " 74107
19	72016/37-74153	2	" " 74153
20	72060/37-74164	1	" " 74164
21	72035/37-74193	5	" " 74193
22	72024/37-9312	4	" " 9312
23	72036/37-9314	3	" " 9314
24	72017/37-9316	3	" " 9316
25	72031/37-9321	1	" " 9321
26	72025/37-9322	4	" " 9322
27	72026/37-9602	1	" " 9602
28	72057/37-LM323K	1	LM323K
29	72048/37-LM380	1	" " LM380
30	72058/37-MC4024	1	" " MC4024
31	72042/37-MFC6040	1	" " MFC 6040
32	72040/37-CD4016	1	" " CD4016
33	72021/37-NE566	1	" " NE566
34	22103/19-311103	1	Trimpot, 10K
35	22502/19-311502	1	Trimpot, 5K
36	22105/19-311105	1	Trimpot, 1M
37	37000/24-160802	1	Capacitor, Electrolytic, 8,000 uf, 16V

## PARTS LIST SPECIFICATION

Dwg. P/L 001660-01

Title PCB ASSY. - PIN PONG - 60 HZ

sheet 2 of 2

Rev. G

Item	Part No.	Qty.	Description
38	35503/24-250501	3	Capacitor, Electrolytic, 500 uf, 25V
39	35254/24-060251	1	" " 250 uf, 6V
40	39100/29-001	2	" Tantalum, 100 uf, 10V
41	35506/24-250100	2	" Electrolytic, 10 uf, 25V
42	35472/24-100050	2	" " 5 uf, 16V
43	35508/24-250010	1	" " 1 uf, 25V
44	34101/27-101104	16	" Ceramic, Disc, .1 uf
45	32221/27-101224	1	" Mylar, .22 uf
46	30332/28-101471	1	" Mica, 470 pf
47	30101/28-101101	1	" " 100 pf
48	30102/28-101221	6	" " 220 pf
49	71001/31-1N4001	6	Diode, 1N 4001
50	31-1N1612	2	Diode, 1N 1612
51	71000/31-1N914	15	Diode, 1N 914
52	71020/32-1N5237	1	Diode, 1N 712 (or 1N 5237), 8.2V Zener
53	70009/34-2N5190	1	Transistor, 2N 5190
54	70000/34-2N3643	3	Transistor, 2N 3643
55	70001/34-2N3544	1	Transistor, 2N 3644
56	19100/19-808W4PO	1	Resistor, 10 Watt, 4 ohm
57	12103/11-0151	1	" 1/2 Watt, 150 ohm
58	11270/19-839C2P7	1	" Carbon, ±5 %, 1/4 Watt, 2.7 ohm
59	11123/10-5123	1	" " " 12K ohm
60	10101/10-0101	4	" " ±10%, " 100 ohm
61	10151/10-0151	1	" " " 150 ohm
62	10221/10-0221	2	" " " 220 ohm
63	10271/10-0271	3	" " " 270 ohm
64	10331/10-0331	7	" " " 330 ohm
65	10102/10-0102	24	" " " 1K ohm
66	10103/10-0103	2	" " " 10K ohm
67	10153/10-0153	2	" " " 15K ohm
68	10181/10-0181	1	" " " 180 ohm
69	10472/10-0472	4	" " " 4.7K ohm
70	10273/10-0273	1	" " " 27K ohm
71	10473/10-0473	1	" " " 47K ohm
72	75103/75-916S	2	Nut, Hex, H6
73	75100/72-1610C	2	Screw, Pan Head, SS, #6-32 x 5/8
74	75101/75-056	4	Washer, Internal Star, #6
75	75102/75-016C	2	Washer, Flat, #6
76	75188/75-1408C	3	Screw, Machine, Pan Hd., #4-40 x 1/2", SS
77	75164/75-914S	3	Nut, Hex, #4-40
78	75194/75-054	5	Washer, Internal Tooth Lock, #4-40
79	75163/75-014S	2	Washer, Flat, #4-40
80	60000/69-001	3	Switch, DPDT
81	81001/90-101	1	Crystal
82	83014/78-06001	1	Wakefield Heatsink
83	001925	1	Printed Circuit Board, Revision C
84	79-20102	7	Useco 2006B Terminals
85	79-58017	1	6 Pin Polarized Male P.C. Conn.
86	001992	1	Heatsink, Diode
87	78-16002	A/R	Thermal Conductive Compound
88	57-216	2	Buss Wire, #16AWG, 1 1/4" Long
89	75-050	2	Washer, Internal Tooth Lock, #10
90	75-910S	2	Nut, Hex, #10-32
91	24-100105	1	Capacitor, Electrolytic, 1 uf, 10V
92	10-0222	1	RESISTOR, CARBON, 10%, 1/4W, 2.2K OHM



PARTS LIST SPECIFICATION

Drawn	
Checked	Mech. Eng. <i>[Signature]</i>
Proj. Eng. <i>[Signature]</i>	Elec. Eng. <i>[Signature]</i>
	REV. B

Rev.	Description	Date	Apprv.	Rev.	Description	Date	Apprv.
A	PROD REL	10/7/74	<i>[Signature]</i>				
B	REV PER ECN 893	10/21/74	<i>[Signature]</i>				

Item	Part Number	Qty.	DESCRIPTION
1	001551	1	Transformer
2	42-70102	1	Transformer
3	90-3001	1	Linefilter
4	79-3201	1	Fuse Holder
5	46-20120	1	Fuse, 2A, Slo-Blo
6	68-001	1	Interlock Switch
7	000268	1	Interlock Switch Bracket
8	72-6608	20	Screw, Sheet Metal, #6, Pan Hd., Phil., 1/2"
9	001998	1	Transformer Cover
10	71-301	1	Staple
11	54-401	1	Line Cord
12	002439	1	Harness
13	47-1001	1	Coin Counter
14	75-2824S	1	Machine Screw, #8 x 1 1/2"
15	75-918S	2	8-32 Nut
16	75-018S	3	Washer, #8
17	A001995	1	Tray, Electronics
18	A001920	1	Harness, Voltage Selection
19*	A001921-01	A/R	Shorting Block, 95V
20*	A001921-02	A/R	Shorting Block, 110V
21*	A001921-03	A/R	Shorting Block, 220V (High Line)
22*	A001921-04	A/R	Shorting Block, 220V (Low Line)
23	75-8808	4	Screw, Wood, Flat Hd., Phil., #8 x 1/2" Lg.
24	78-25001	A/R	Cable Clamp
25	000871	1	Label
26	79-20101	1	Molex Male Pin 02-09-2011
27	79-58019	1	Molex Plug 03-09-2118

\*Install Shorting Block per voltage required

REVISIONS		INITIALS and DATE	
SYM	DESCRIPTION	DRFTG	CHECK
A	PROD BEL	04/14	EC

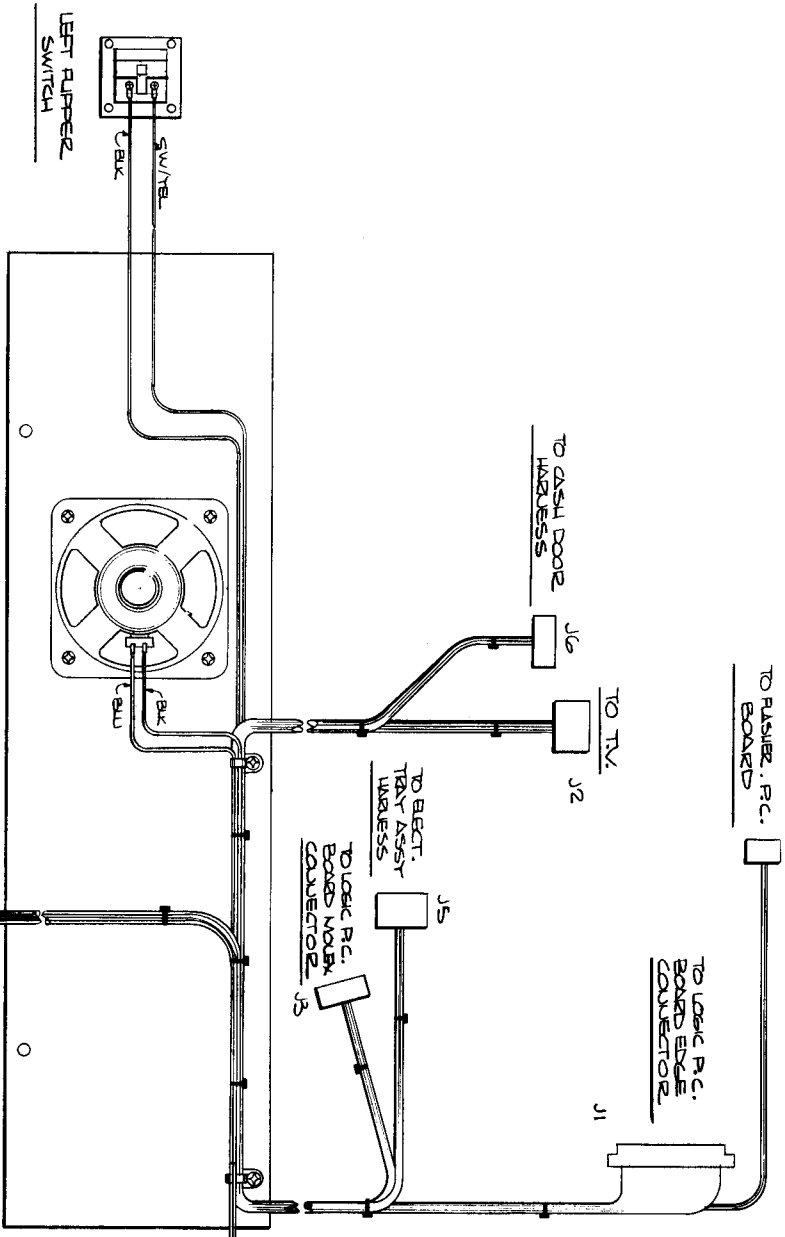

INTERPRET THIS DRAWING FOR USA 1743 UNLESS OTHERWISE SPECIFIED DIMENSIONS ARE IN INCHES TOLERANCES ON: FINISHES - 4:116 5:4:1 ANGLES - 4:10 3:3:3 03 SURFACE FINISH - 3:3:3 4:3:10 MATERIAL:		DRAWN BY DC DATE 0-11-74 CHECKED REGION ENGINEER PROJECT ENGINEER DOCUMENT CONTROL	TITLE HARNESS INSTALLATION DRAWING ATARI INCORPORATED 14400 Winchester Boulevard Los Gatos, California 95030
APPROVED 	SIZE D SCALE 1/2	DRAWING NO. 002446 SHEET 1 OF 1	REV A

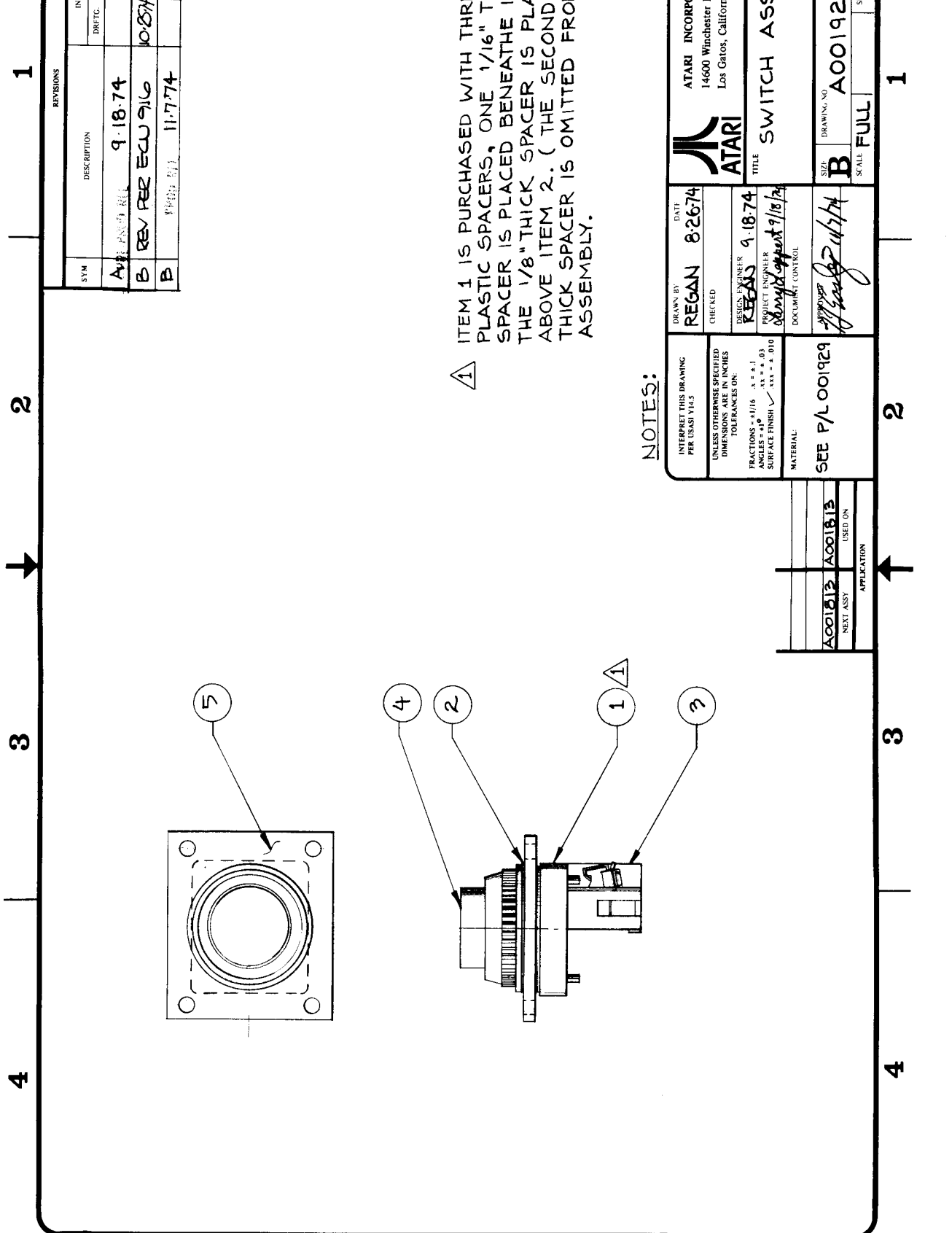

⚠ ITEM 1 IS PURCHASED WITH THREE PLASTIC SPACERS, ONE 1/16" THICK SPACER IS PLACED BENEATH ITEM 5. THE 1/8" THICK SPACER IS PLACED ABOVE ITEM 2. (THE SECOND 1/16" THICK SPACER IS OMITTED FROM THE ASSEMBLY.)

NOTES:

INTERPRET THIS DRAWING PER USASI Y14.5  
 UNLESS OTHERWISE SPECIFIED DIMENSIONS ARE IN INCHES  
 TOLERANCES ON:  
 FRACTIONS = ±1/16 A ±.1  
 ANGLES = ±10  
 SURFACE FINISH = XXX ±.010  
 MATERIAL:  
 SEE P/L 001929

SYM	DESCRIPTION	INITIALS and DATE	
		DRAFT.	ENGR.
A	9-18-74	<i>[Signature]</i>	EC
B	REV PER ECU 9/16	10-25-74	EC
B	REV PER ECU 11-7-74	<i>[Signature]</i>	1/EC

<p>ATARI INCORPORATED          14600 Winchester Boulevard          Los Gatos, California 95030</p>	<p>DATE: 8-26-74          DRAWN BY: REGAN          CHECKED: REGAN          DESIGN ENGINEER: REGAN          PROJECT ENGINEER: <i>[Signature]</i>          DOCUMENT CONTROL: <i>[Signature]</i></p>	<p>ATARI          SWITCH ASSEMBLY</p>
<p>SEE P/L 001929</p>	<p>SCALE: FULL          DRAWING NO: A001929          SHEET 1 OF 1</p>	<p>SIZE: B          RIV: B</p>

A001929	USED ON
NEXT ASSY	APPLICATION

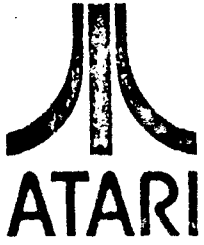

Job Title SWITCH ASSEMBLY  
PIN PONG

Dwg. P/L 001929

*Parts List Specification* sheet 1 of 1

Drawn Cynthia		
Checked	Mech. Eng. <i>BEN CHEN</i>	Rev.
Proj. Eng.	Elec. Eng. <i>Larry Leppert</i>	B

Rev.	Description	Apprv.	Rev.	Description	Apprv.
A	PREPROD REL 9/23/74	<i>RC</i>			
B	Rev per ECN 916 10/25/74	<i>RC</i>			
B	PROD REL 11/7/74	<i>RC</i>			

Item	Part. No.	Qty.	Description
1	60013/60-0102	1	Switch, Push-button, Rundel (#R2)
2	60011/60-0301	1	Ring, Anti-Rotation (#SA 19)
3	60012/60-0401	1	Contact Block, SPST, N.O.
4	60014/60-0202	1	Cap, Switch (Yellow), #AY 1
5	001819	1	Bracket, Mounting, Control

REVISIONS		INITIALS AND DATE	
SYM	DESCRIPTION	DEPT	ENGR
C	PRODUCTION RELEASE	9/2	[Signature]
D	REV. PER ECN 751, 811, 812	9/23	[Signature]
E	REV. PER ECN 826	11/24	[Signature]
F	REV. PER ECN 871	11/24	[Signature]
G	REV. PER ECN 1071	1/15	[Signature]

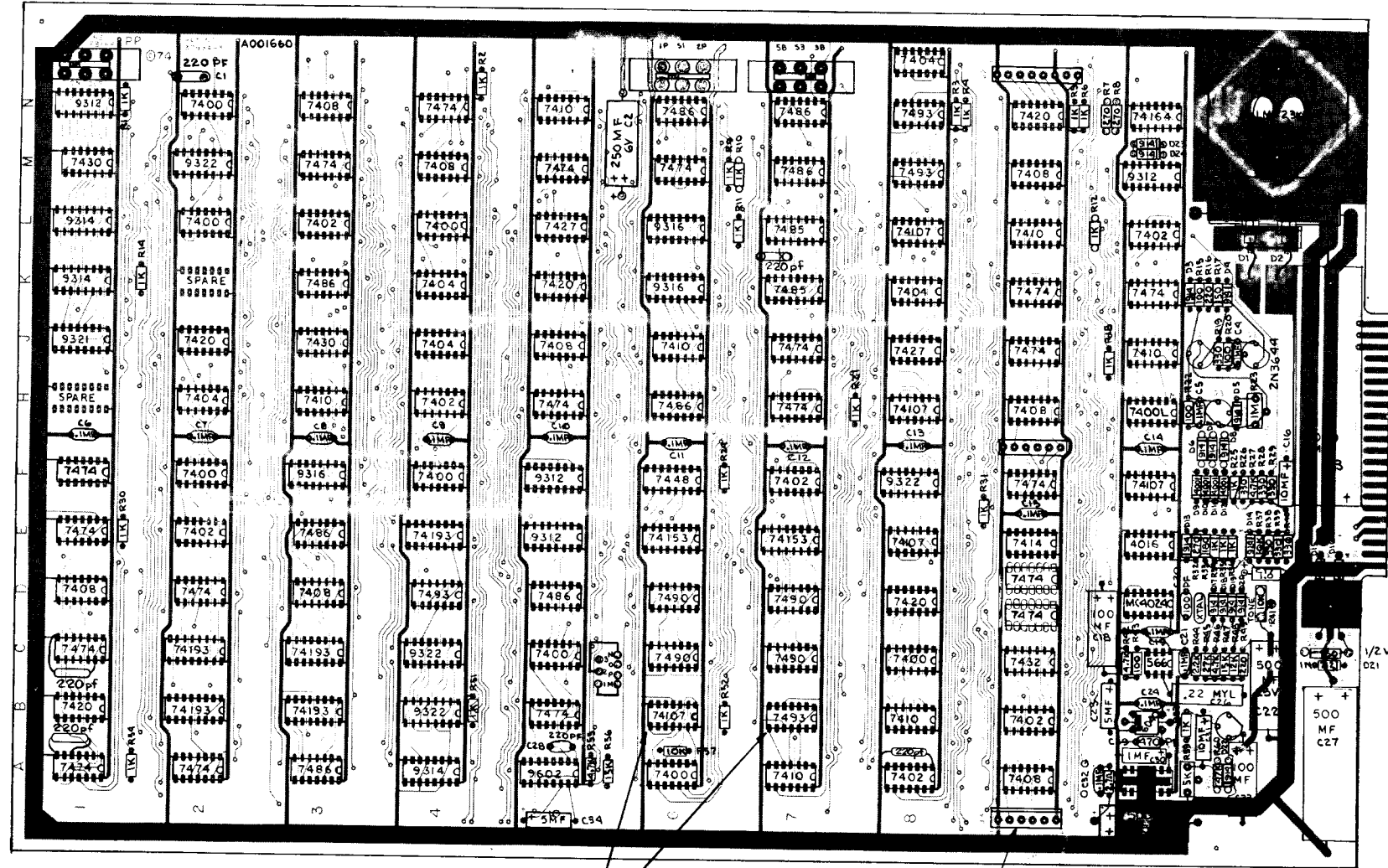

APPLY ITEM 87 (THERMAL COMPOUND) BETWEEN LM323 AND HEATSINK

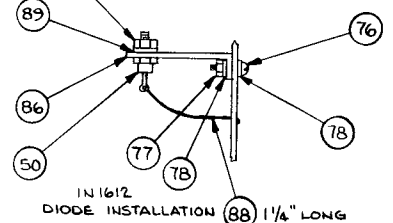
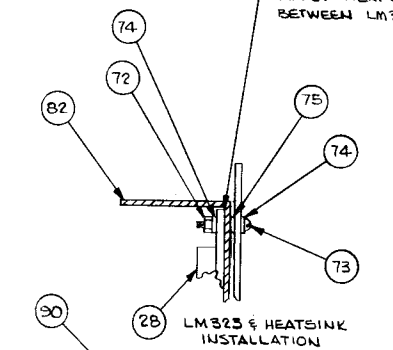

- MODIFICATION LIST**
1. ADD 220 pf CAPACITOR BETWEEN PINS 5 AND 7 OF A1.
  2. ADD 220pf CAPACITOR BETWEEN PINS 7 AND 13 OF C1.
  3. ON CIRCUIT SIDE OF BOARD, CUT TRACE TO K7 PIN 11 AND JUMPER TO ADJACENT TRACE AS SHOWN.
  4. ADD 220pf CAPACITOR BETWEEN PIN 1 OF A8 AND GND BUSS.

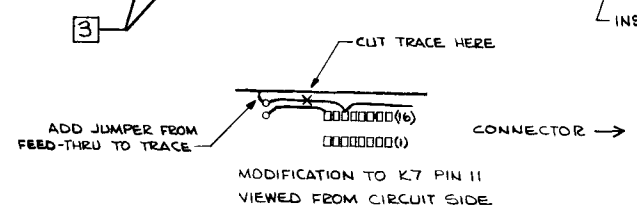
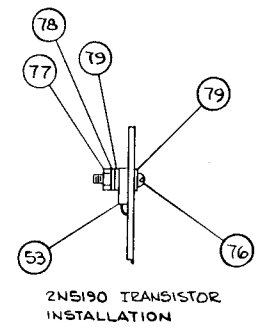

4. FOR 60HZ, SEE P/L 001660-01.  
FOR 50HZ, SEE P/L 001660-02.
3. INTEGRATED CIRCUITS B6 (74107) AND B7 (7493) ARE LOADED FOR 50HZ OPERATION ONLY.
2. ALL TRANSISTORS ARE 2N3643.
1. ALL DIODE ARE IN14.
- NOTES: UNLESS OTHERWISE SPECIFIED.

INTERPRET THIS DRAWING PER USAS 7145	DRAWN BY: PCS	DATE: 9/2/74	ATARI INCORPORATED 14600 Winchester Boulevard Los Gatos, California 95030
UNLESS OTHERWISE SPECIFIED DIMENSIONS ARE IN INCHES TOLERANCES ON:	CHECKED:	DESIGN NUMBER:	
FRACTIONS: 1/16, 1/8, 1/4, 1/2, 3/4	PROJ. ENGR.:	DOC. CONTROL:	TITLE: ASSEMBLY PIN PONG (50HZ/60HZ)
MATERIAL:	APPROVED:	SCALE: 1/1	SHEET: 1 OF 1
P/L 001660-01			
50 HZ			
P/L 001660-02			

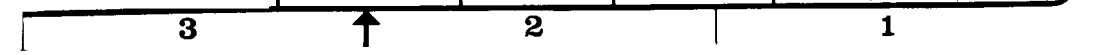



8 7 6 5 4 3 2 1

REVISIONS				
SYM	DESCRIPTION	INITIALS and DATE		
		DRFTG	CHECK	ENGRG
A	PROD REL	10/9/74	[Signature]	[Signature]
B	REVISED PER ECN 893	11/9/74	[Signature]	[Signature]

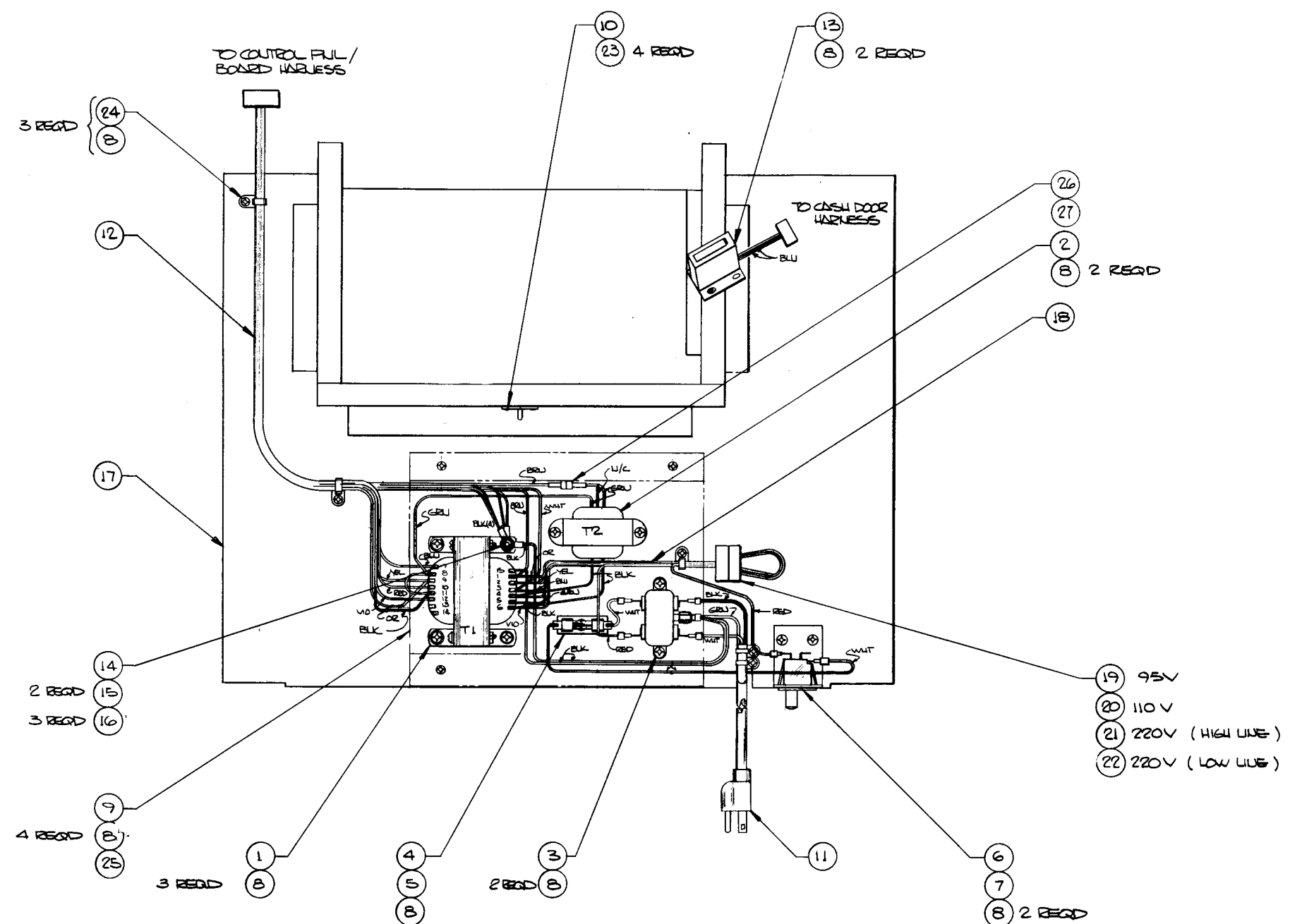

D  
C  
B  
A

D  
C  
B  
A

DRAWING NO. A001927  
SHEET 1 OF 1

NOTICE TO ALL PERSONS RECEIVING THIS DRAWING: CONFIDENTIAL. Reproduction Forbidden without the specific written permission of Atari Inc., Los Gatos, California. This drawing is only conditionally issued, and neither receipt hereon to use, the subject matter of the drawing or any design produced therefrom, nor any right to manufacture or use the subject matter of the drawing or any design produced therefrom, is granted or the subject matter thereof unless by written agreement with or written permission from the corporation.

APPROVED	DATE
[Signature]	10/16/74

INTERPRET THIS DRAWING PER USASI Y14.5	DRAWN BY DC DATE 10/9/74	<p>ATARI INCORPORATED 14600 Winchester Boulevard Los Gatos, California 95030</p>
UNLESS OTHERWISE SPECIFIED DIMENSIONS ARE IN INCHES TOLERANCES ON:	CHECKED RC	
FRACTIONS = +.1/16 X = .1 ANGLES = 45° SURFACE FINISH ✓ .25 X = .010	DESIGN ENGINEER RC PROJECT ENGINEER [Signature] 10/16/74 DOCUMENT CONTROL	TITLE ASSEMBLY ELECTRONICS TRAY
MATERIAL: SEE PL 001927	APPROVED [Signature] 10/16/74	SIZE D DRAWING NO. A001927
NEXT ASSY USED ON	APPLICATION	SCALE 1/2 SHEET 1 OF 1

8 7 6 5 4 3 2 1

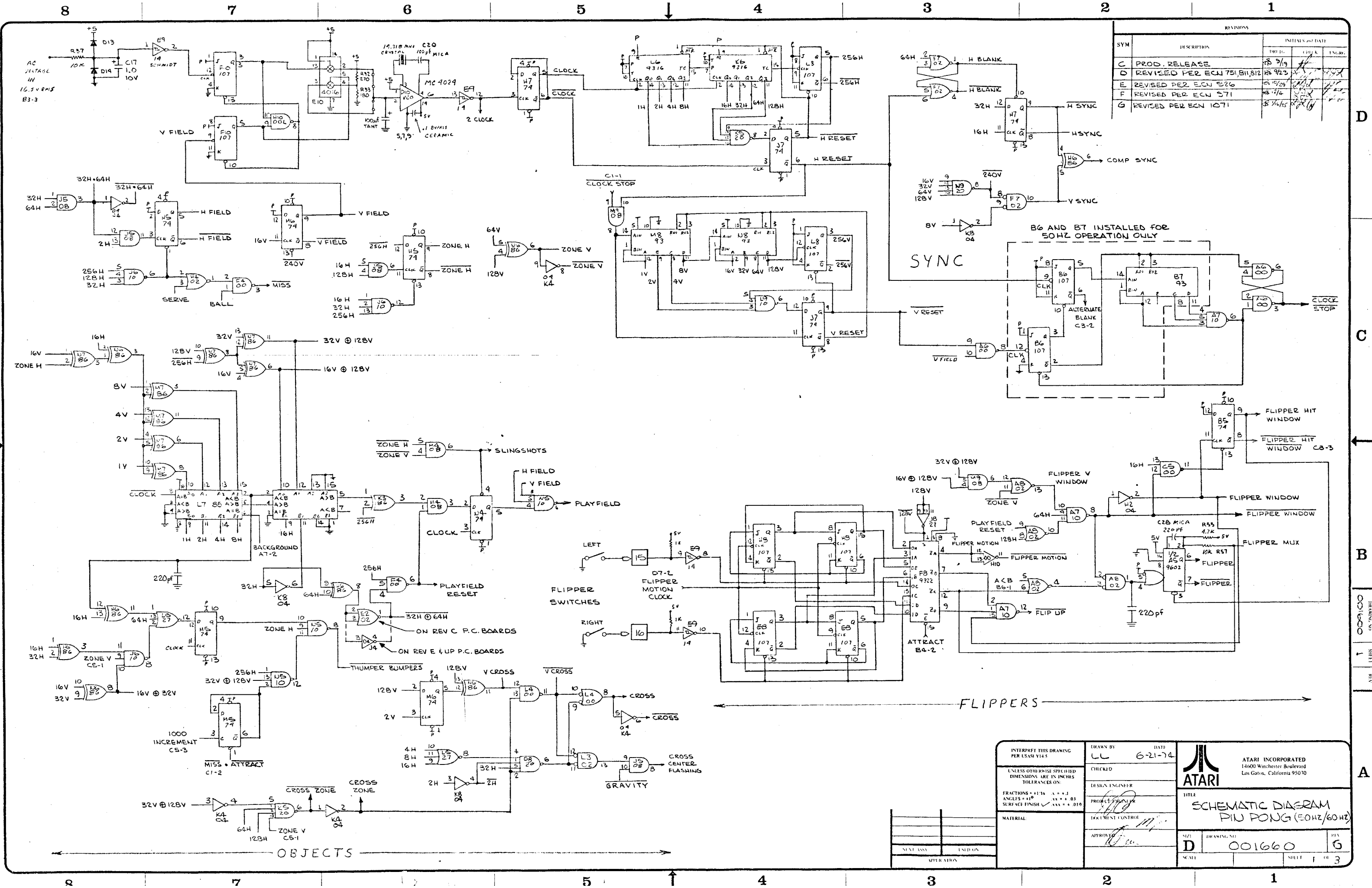

REVISIONS			
SYM	DESCRIPTION	DATE	INITIALS and DATE
C	PROD. RELEASE	8/9/74	
D	REVISED PER ECN 751, 811, 812	8/9/74	
E	REVISED PER ECN 826	8/14/74	
F	REVISED PER ECN 871	8/14/74	
G	REVISED PER ECN 1071	8/14/74	

INTERPRET THIS DRAWING PER IAS 914.5 UNLESS OTHERWISE SPECIFIED DIMENSIONS ARE IN INCHES TOLERANCES ON: FRACTIONS ±.125 ANGLES ±1° SURFACE FINISH ✓ ALL +.010	DRAWN BY <b>LL</b>	DATE <b>6-21-74</b>	ATARI INCORPORATED 14600 Winchester Boulevard Los Gatos, California 95070
	CHECKED DESIGN ENGINEER PROJECT MANAGER DOCUMENT CONTROL APPROVED NAME AND SIGNATURE	TITLE <b>SCHEMATIC DIAGRAM PING PONG (50HZ/60HZ)</b>	
MATERIAL PARTS LIST OPERATION	SIZE <b>D</b>	DRAWING NO <b>001660</b>	REV <b>G</b>
SCALE		SHEET <b>1</b>	OF <b>3</b>

D  
 C  
 B  
 A

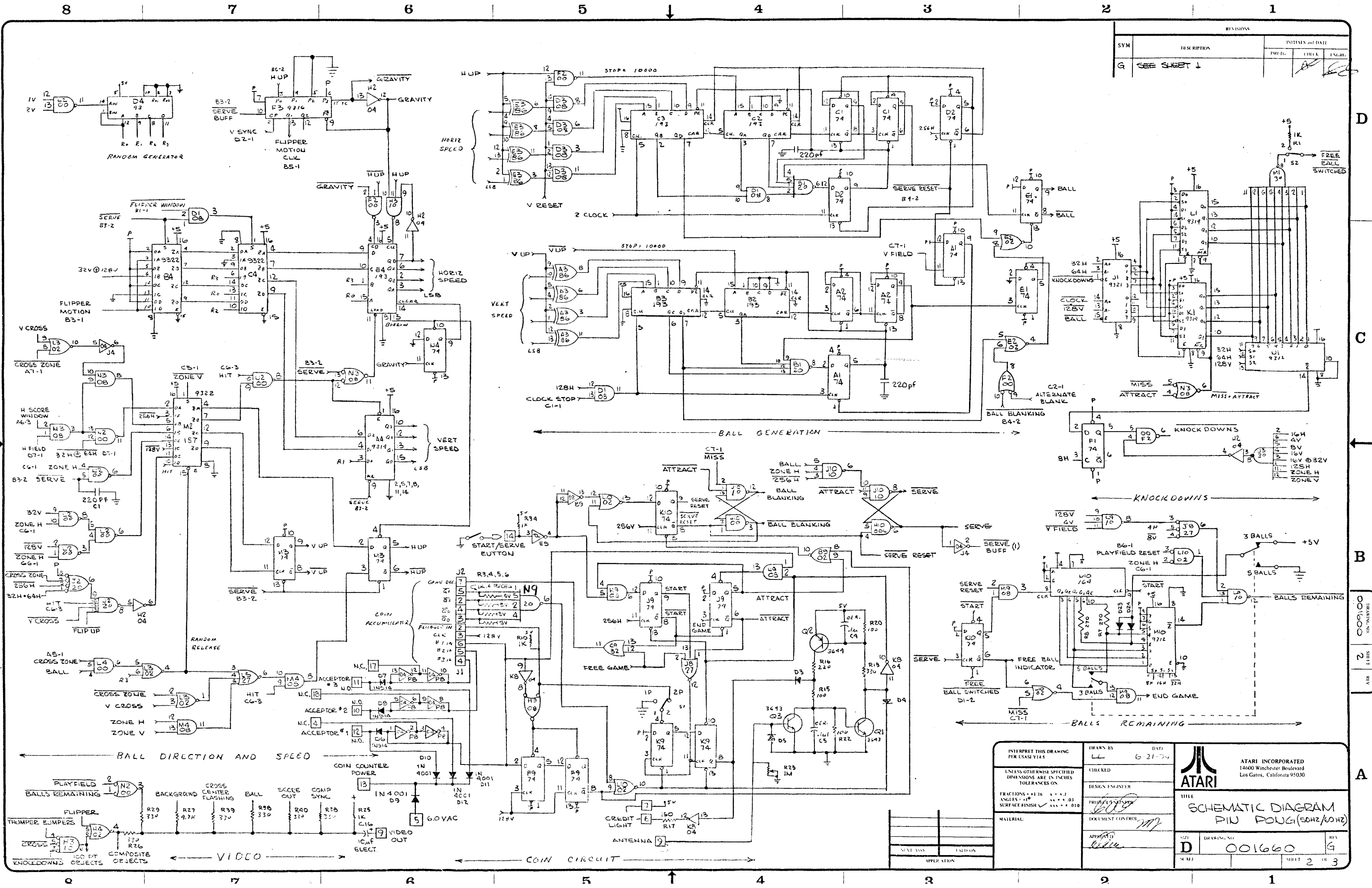

REVISIONS			INITIALS and DATE	
SYM	DESCRIPTION	PREP. BY	CHECK	ENGR.
G	SEE SHEET 1			

INTERPRET THIS DRAWING PER CSAS1 Y14.5 UNLESS OTHERWISE SPECIFIED DIMENSIONS ARE IN INCHES TOLERANCES ON:	DRAWN BY: LL DATE: 6-21-74	ATARI INCORPORATED 14600 Winchester Boulevard Los Gatos, California 95030
	CHECKED: [Signature] DESIGN ENGINEER: [Signature] PROJECT MANAGER: [Signature] DOCUMENT CONTROL: [Signature]	
MATERIAL:	APPROVED: [Signature]	SIZE: D DRAWING NO: 001660 REV: 4 SHEET: 2 OF 3

REVISIONS		
SYM	DESCRIPTION	INITIALS and DATE
G	SEE SHEET J	

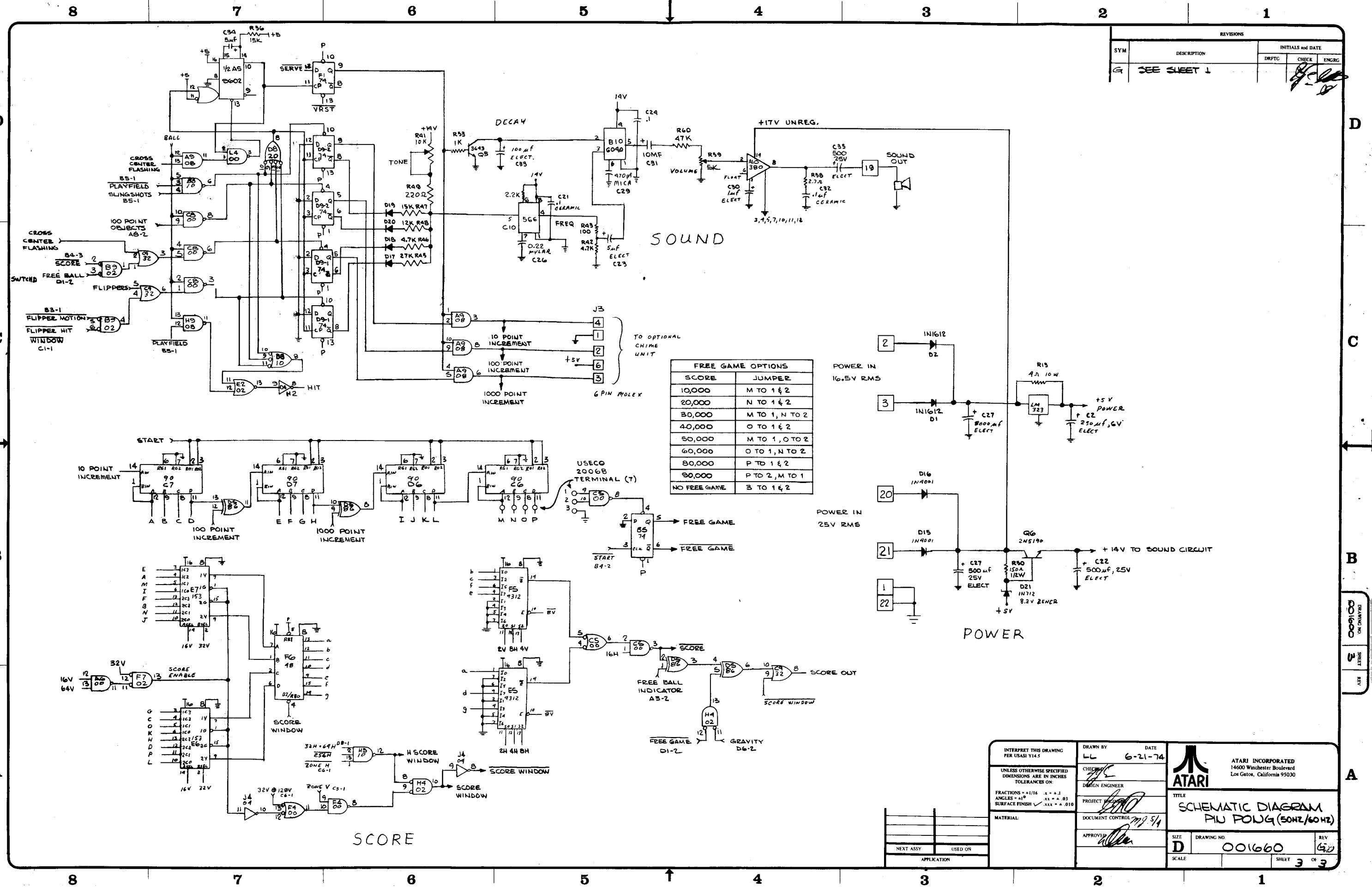

SCORE	JUMPER
10,000	M TO 1 & 2
20,000	N TO 1 & 2
30,000	M TO 1, N TO 2
40,000	O TO 1 & 2
50,000	M TO 1, O TO 2
60,000	O TO 1, N TO 2
80,000	P TO 1 & 2
90,000	P TO 2, M TO 1
NO FREE GAME	3 TO 1 & 2

INTERPRET THIS DRAWING PER USASI Y14.5 UNLESS OTHERWISE SPECIFIED DIMENSIONS ARE IN INCHES TOLERANCES ON: FRACTIONS = ±1/16 DECIMALS = ±.03 SURFACE FINISH = XXX = A .010	DRAWN BY: LL CHECKED BY: [Signature] DESIGN ENGINEER	DATE: 6-21-74 PROJECT: [Signature] DOCUMENT CONTROL: [Signature]	ATARI INCORPORATED 14600 Winchester Boulevard Los Gatos, California 95030
	MATERIAL:	APPROVED BY: [Signature]	
NEXT ASSY: [Blank] USED ON: [Blank] APPLICATION: [Blank]	SIZE: D SCALE: [Blank]	DRAWING NO: 001660 SHEET 3 OF 3	REV: (4)

DRAWING NO: 001660  
 SHEET 3 OF 3

REVISIONS			
SYM	DESCRIPTION	INITIALS and DATE	
		DRFTG	CHECK ENGRG
B	PROD BEL REVISIONS PER ECN 874	10/15/74	RC
C	REVISED PER ECN 892	10/21/74	RC
D	REV PER ECN 1425	5/2/75	RC

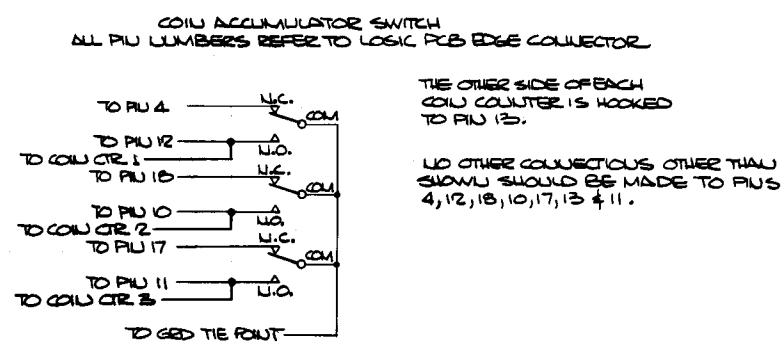
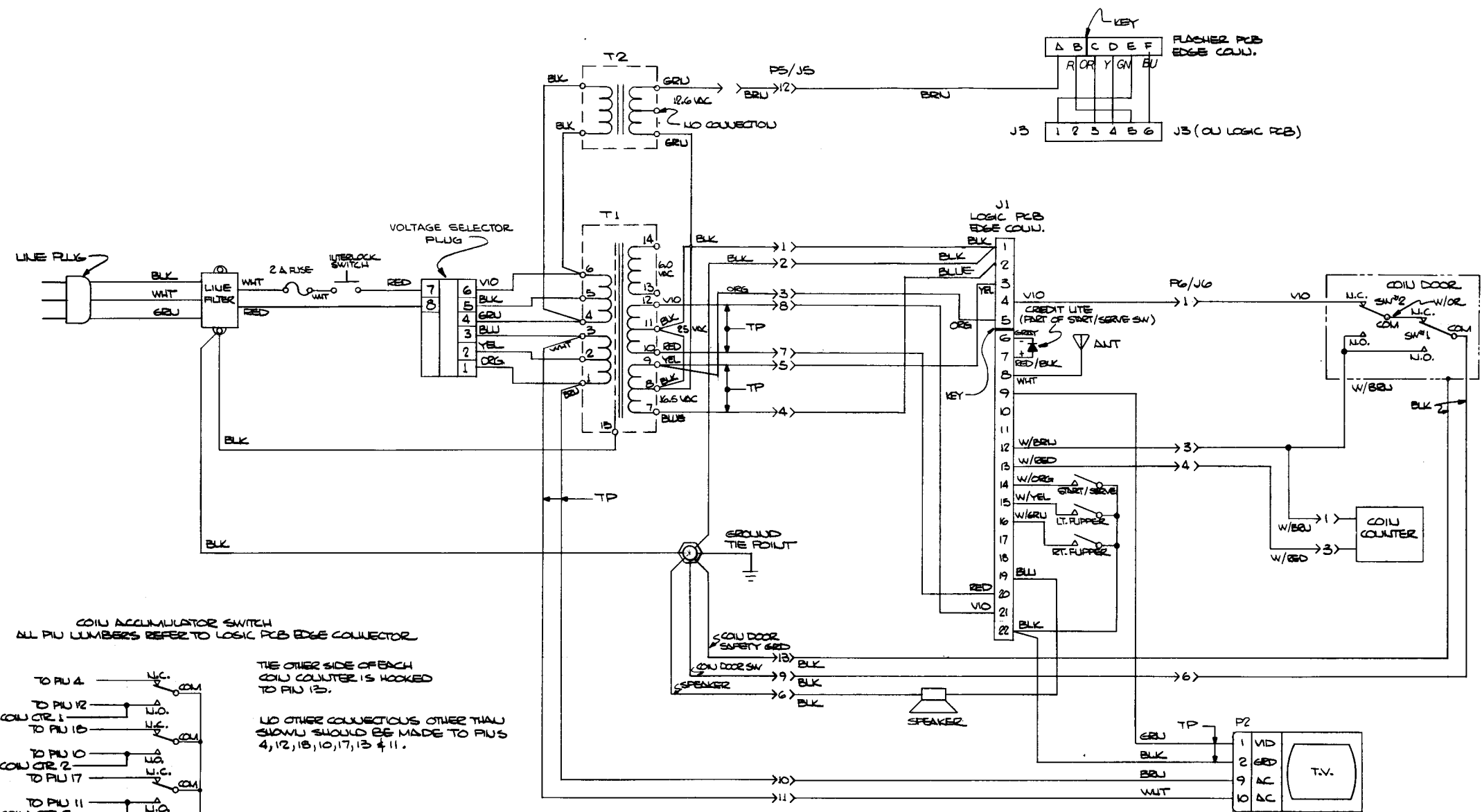

10 PU MOLEX VOLTAGE SELECTOR PLUGS

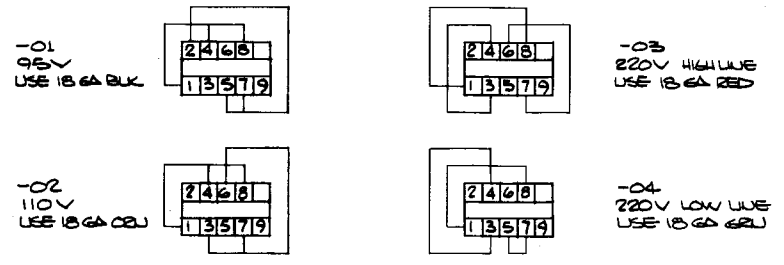

\* SEE DRAWING 0001921 FOR FULL DETAIL

APPROVED	DATE
COOK	10/15/74

INTERPRET THIS DRAWING PER USASI Y14.3	DRWN BY <b>COOK</b>	DATE 10/15/74	<p>ATARI INCORPORATED 14600 Winchester Boulevard Los Gatos, California 95030</p>
UNLESS OTHERWISE SPECIFIED DIMENSIONS ARE IN INCHES TOLERANCES ON:	CHECKED	DESIGN ENGINEER <b>RE</b>	
FRACTIONS = 1/16 .5 = .5 ANGLES = 10° .25 = .25 SURFACE FINISH = .25x = .25x	PROJECT ENGINEER <i>[Signature]</i>	DOCUMENT CONTROL	TITLE <b>WIRING DIAGRAM PING PONG</b>
MATERIAL:	APPROVED <i>[Signature]</i>	DATE	SIZE <b>D</b>
NEXT ASSY	USED ON	APPLICATION	DRAWING NO. <b>001982</b>
			REV <b>0</b>
			SHEET 1 OF 1

DRAWING NO. 001982

D  
C  
B  
A

D  
C  
B  
A