

PURSUIT

Service Information
(PCB Logic)



PURSUIT

TABLE OF CONTENTS

A.	INTRODUCTION/WARRANTY	1
B.	NEW MACHINE SET-UP PROCEDURE	2
C.	SERVICE ACCESS	2
D.	NEW MACHINE CHECKOUT	3
E.	PLAY	5
F.	CIRCUITS	9
G.	SET-UP PROCEDURE	21
H.	PRODUCTION BOARD TESTS	23
I.	MOTOROLA MONITOR	25
J.	Q-530 COIN ACCEPTOR ADJUSTMENT & MAINTENANCE	27
K.	GENERAL MACHINE MAINTENANCE	29
L.	TROUBLESHOOTING	30
M.	P.C.B. SHIPPING	33

A. INTRODUCTION/WARRANTY

PURSUIT is a video amusement device which simulates flying a fighter plane.

This game has been designed with solid state circuitry to be as maintenance free as possible. However, as with all devices mechanical or electrical, there may be minor problems. If the printed circuit board (PCB) fails within the 90 day*warranty period, contact the distributor from whom the game was originally purchased for replacement or repair instructions. All such warranty returns must be accompanied by completed warranty return forms. Any PCB repairs attempted by anyone other than authorized Atari Service Center personnel will void the warranty. If the PCB fails after the warranty period has expired, it will be repaired for a nominal parts and labor charge.

Atari, Inc. warrants the T.V. monitor for a period of 30 days commencing the day of shipment from the Atari factory. If the monitor fails within that period, immediately contact the distributor from whom the game was originally purchased for repair or replacement instructions. Any T.V. repairs (other than replacement of fuses or adjustments) attempted during the warranty period by anyone other than authorized Atari Service Center personnel will void the warranty.

If the T.V. monitor fails after the warranty period has expired, it may be returned to the distributor where it will be repaired for a nominal parts and labor charge, or it may be taken to any competent T.V. repair shop

*(From date of shipment from the factory)

B. NEW MACHINE SET-UP PROCEDURE

Before turning this machine on, inspect it carefully for any damage which may have occurred during shipment. Inspect both interior and exterior of the machine for any obvious damage to the cabinet or internal components. Check for cracked or broken cabinet parts, assemblies pulling loose, broken or disconnected wires or foreign objects shorting electrical connections. After the machine has been plugged in and turned on, perform the checkout procedure.

C. SERVICE ACCESS

All servicing is performed at the rear of the machine through the rear door which provides access to all components, sub-assemblies, and adjustments with the exception of the coin box. The coin door is located on the front of the machine underneath the control panel. To remove the coins, unlock the metal coin door and open. This exposes the coin box.

To reach the interior of the machine, unlock and remove the rear door. Please note that an interlock switch is provided for this door so that the machine is completely turned off whenever this door is opened. These switches protect the operator from accidental shock and so they must always be kept in perfect working order. If the machine is adjusted or tested with the rear door open, the interlock switch must be placed in the closed (or "on" position) by pulling out the white actuator shafts.

WARNING: The covered black terminal block carries full line voltage whenever the line plug is connected to a power outlet. This cover should be removed only with the line plug disconnected. Do not leave off the cover once it has been removed.

D. NEW MACHINE CHECKOUT

As each new machine leaves the factory, every component and subassembly is carefully checked for proper operation. However, since parts may have been damaged or adjustments changed during shipping, the following checkout procedure must be repeated prior to placing the machine on location:

1. Inspect both the exterior and interior of the machine for obvious shipping damage such as cracked or broken cabinet parts, sub-assemblies broken loose, etc.
2. Carefully inspect the interior of the machine to see that all solder joints, slip-on connectors and plug-in type connectors are firmly seated. Pay particular attention to the PCB edge connector, the fuses and the connectors to the potentiometers. Also check the connections to the coin switch, the T.V. monitor, the interlock switches and all the other Molex-type connectors.
3. Plug the machine in, and pull out the white actuator shafts of the interlock switches if the rear door is open. Inspect the CRT (cathode ray tube) image for a steady and sharp picture which exhibits the proper levels of brightness and contrast.
4. Insert several old and new coins into the coin acceptor. No genuine coin should be rejected and each coin insertion should step the coin counter one digit. Depress the coin rejector button to make sure that the linkage is operating smoothly.
5. Coin insertion should start the game. (Check for proper game sequence, making sure that all aspects of the game - i.e. plane display and control, score count and display, etc. are functioning correctly. If you are not familiar with the game sequence for Pursuit, read the game sequence description.

6. The door locks should turn to the "locked" and "unlocked" positions smoothly and the doors should open and close without binding.
7. The interlock switches must turn off the entire machine when the rear door is opened. (See the "WARNING" under Section C).

E. PLAY

Picture:

Joystick moves forward and backward and
from side to side.

In the preceding figure, the view is from the cockpit of a Pursuit airplane. The cross hairs are the sights of an airplane-mounted machine gun.

Control is with a joystick. Pushing the joystick forward causes the airplane to dive. Backward, it causes the airplane to climb. Turning right is accomplished by moving the joystick to the right, and turning left is accomplished by moving the joystick to the left. This is exactly how a real World War I Pursuit aircraft was controlled.

Attract Mode: (1) Enemy aircraft (being followed) remains on the screen. It will normally wander randomly up and down and from side to side. Occasionally it will stick on edge awaiting random circuit instructions to push it back towards the center of the screen.

(2) Sound is shut off in attract mode permitting machine gun to be fired continuously. This is evident by a flashing spot of light in the center of the cross hairs.

(3) If the wandering enemy aircraft moves through the center of the cross hairs, it will be shot down. A shoot down is followed by an explosion sequence. The enemy disappears while the debris of the destroyed aircraft radiates outward from the center. In the latter half of the explosion sequence, a new airplane reappears on the screen. Another plane is chalked up on the scoring strip on the right hand side of the screen.

Play Mode: The enemy aircraft moves randomly as in the attract mode, but now we control our airplane to shoot him down. If the enemy is below us we dive to get him. Pushing the stick forward does this. The horizon is seen to move up while we get nearer to getting the enemy into the gun sights. Conversely, if the enemy is high we climb to get him. The horizon moves down as we get closer. Engine sounds are present in the play mode and they change depending on whether we are climbing or diving.

If the enemy is to the right or left we move the stick sideways to catch him. A motion to the right causes the cross hairs to tilt right simulating the bank of the other airplane. The machine gun is fired by pressing the button on top of the joystick. In addition to flashes of light in the center of the cross hairs, a machine-gun sound comes from the speaker.

A hit results in the explosion of the enemy with the attendant picture of flying debris (see Attract Mode), but we also have the explosion noise. The noise is slightly delayed from the hit. There are 2 series of explosions. The enemy disappears from the screen during the first explosion but he reappears during the second explosion.

Scoring and game time are recorded on the left and right sides of the screen.

Play time shows up as a bar on the left. This is intended to simulate a gas gauge. It starts as a bar that extends to the top. As the game proceeds it shortens until at the end of the game it disappears. Extended play results in a gas tank refill occurring at the skill level that has been set into the PCB with coded switches.

Scoring is done with small marker planes on the right side. A hit marks one plane (light) on the upper right. A score of 15 (light) airplanes is possible, then the score restarts at the top with dark markers. 30 is the maximum recorded score. In addition to score marks, the illuminated tags are as follows:

- 4 WASHOUT
- 8 STUDENT PILOT
- 12 EAGLE
- 16 ACE

Switches on the PCB enable setting to any of these levels for Extended Play. For example, if Extended Play is set for EAGLE, then when EAGLE is attained the game time starts over again. This is seen as a refill of gas. At the end of the game sound and control cease.

F. CIRCUITS

1. Coin and game time. Schematic region CC6, DD6, 7.
 - a. Devices Q5 A8₁₁ A8₈ A7₄ B6₁₂ Q6₁ A7₂, A8₆ E6, D7, A6₃
 - b. Game starts when a voltage is applied at terminal 18. This is also the terminal to which the coin counter is connected. Current to the coin counter flows through the coin switch. According to cherry switch this current helps keep this switch operational. Diode CR13 holds down voltage spikes. Voltage must be at terminal 18 long enough for C36 to integrate up to Q5 conduction (.7V). Q5 sets Flip Flop A8₁₁₋₈ when it conducts. A8 is a Hysterisis device to give extra protection against noise or sparks triggering the game ON. C23 also helps prevent this. GT means GAME TIME and is used in the same sense as ATTRACT is used in other games. When GT is TRUE 555 timer (E6) is released to operate (Terminal 4). E6 operates in the A stable mode. 8 cycles of operation comprise a Game. These cycles of operation are counted in 7493-D7. The termination count is when the 4's significant FF comes ON. This goes through B6, A6 and A7 to reset the Game FF (A8₁₁₋₈). When power is first applied to the game or an interruption in power occurs, the Q6 circuit assures that game time will be in the OFF state. The rising 5V charging C37 causes Q6 to conduct and reset via A6 and A7.

2. Game time display. Schematic region DD6-EE6
 - a. Devices C7_{11,8,6} B7_{12,6,4,2} A7₄, C6₄, D4₈, A7₈

- b. The game time count is compared to functions V32,64, and 127 in C7. When scan has moved down the screen to the point that comparison is TRUE, this result is latched in C6₄. The "moving down" vertical signal is ANDed with A functions in D4₈ to generate the fuel video bar.
3. Score, Memory and Display. Schematic region CC5,6 - DD5 - EE5.
- a. Devices L6₃F7₆, L8₈, J4₁₂J7, J6_{6,11,83}...K6_{6,10,8,4}...K3₁, K3₄, N4₁₃, K4₁₁K4₈, L4₃, L4₁₁, K4₃K3₁₃₋₁₀, D4₆, M4₈, A7₁ F6₂₋₁₀₋₄, C6₉, Q9, Q10, Q11, Q8, Q12
- b. Score memory is 5 bit counter L6, J7. At GT score is reset to "zero" via L6₁₃ and B6₆. Score is accumulated by counting explosion pulse arrowing from L6₅. Score is compared with Functions V16, V32, V64 and V128 in comparison to J6 to generate a pulse when vertical scan moves down to the amount of score count. The occurrence of this compare is stored in FF, K3₁₁, K3₄. The correct number of score marks (airplanes) is gated in at D4₅. Airplane shape is formed at inputs 1,2, and 4 to D4. FF-N4₁₃ and K4₁₁ form the "line" for score wings. The major position of the score body is formed in L4₃₋₁₁ and K4₃. Further shaping and vertical segmentation is done by K3₁₃ and K3₁₀. Exclusive gate M4₈ is used to reverse the polarity of the score signal from white to black for score counts 15 to 30. At count of 15 is by J4₁₂ and the connection to L6₄ causes the least significant bit to be forced to ONE on the next count. This is done for skip count 15-17 as polarity of score changes. Otherwise there would have been no score showing at the 16th

score. Score is decoded at H7 for operating skill lights (H7 is BCD to decimal order). DIP switch P6 selects level at which extended play starts (4 to 8, 12, or 16). When the extended play level is reached FF C6₉ is set lighting EXT PLAY lamp and resetting fuel to full via A7₂A8₆. A8₆ is a hysteresis gate and is operated in this circuit as a monostable detecting rising voltage (FF-C6₉ coming ON).

4. Sound circuits. Schematic region DD5, EE5-6-7-8/
 - a. Devices QX, N3, Q1, N2, K8, N8, N5, LM380, M8₆L8₂Q17.
 - b. Machine gun sound is generated by discharging capacitor C43 through the speaker voice coil. The machine gun pulses operate relay L10 to do this. R118, CR8, CR11 are noise suppression components to limit kickback from speaker inductance due to machine gun operation. C43 recovers its charge between shots through R115. Machine gun sound is enabled only during GT (M8₁). The fact that audio from LM380 is disabled during machine gun sounds is scarcely discernable, but this causes considerable distortion of explosion sounds. Therefore, explosion disables the machine gun (M8₂). The explosion sound is constructed from a noise source (A1 and N2) and a solid variable gain amplifier QX and CA3080. Noise is generated by Q1 which is a 2N3643 whose base to emitter junction is forced into an avalanche (Zener) mode by applying 15 volts through 680K. In this mode white noise is generated. The noise is amplified by N2 to the extent that some clipping occurs.

Noise is input to CA3080 at Pin 3 after the attenuation of 6.8K/150K. The CA3080 amplifies fully when QX pulls up pin 5. The rate of pull-up is controlled by R13. The rate of decay is controlled by R12. Motor sounds are generated digitally in A stable Multi K8 (LM555) and counter 7493 N9. The basic frequency is generated in K8. This frequency is changed to indicate climbing or diving by a varying D.C. input from the horizon circuit (MS at AA2). The airplane engine sound is constructed from Fundamental and appropriate mixing of harmonics. This mixing is done across R120. The highest frequency comes via R117. The next frequency down is a contribution of differentiated spikes via C35. The lowest frequencies are added via R119 and R118. Explosion is normally simulated by a sharp rise in break up sound with a relative slow fading of this sound. In Pursuit, the rise is also slow. A normal explosion is made up of 2 separate explosions as controlled by explosion counter N7. (BB5).

5. Power Supply. Schematic Region CC7-8, DD6-8.
 - a. Devices. (CR6 CR7) for scoring lights CR11 CR12, LM309.
 - b. Five volts is supplied by the TV chassis. The 5 volt wire is larger than the other wires in the cable to minimize voltage drop. For 15 volts the unfiltered voltage appears across C42. The divider R112 and R113 changes the LM309 from a 5 volt regulator to a 15 volt regulator. Actually it is connected as a 10 volt regulator with a +5 volt as ground reference. This was done to increase the accuracy of the +15 volts. A diode (CRX) is connected from +5 volts

to +15 volts to prevent the +15 volts from being much lower than 5 volts at turn on. This situation could cause lock up of the 15 volt supply. Lamp power is supplied unfiltered from CR6 and CR7.

6. Timing Circuits. Schematic region 3 and 4 all across schematic.

a. Devices $A1_{all}$, C1, D1, D2, E3, D3, C3, B3 A3, $C2_{all}$, $E4_{all}$, $A5_{all}$, H3₈₋₁₂₋₁₀, $B2_{all}$, $B1_{all}$, $A2_{all}$, E2₁₀₋₁₃, $A1_8$.

b. A new crystal frequency is used in Pursuit. This frequency was selected because the logic functions that it generated in division divides the screen in a much more symmetrical way. This can be appreciated by operating the explosion circuit and observing the symmetrical function radiants outward from the exact center of the screen.

A ripple counter is used throughout. To avoid problems with ripple propagation, intergate pulses BT and MF are generated near the beginning to supply levels that occur only after all settling has occurred. The division to horizontal drive frequency is divided by (256 x 3). There are no counter resets required although the divide by 3 counter D2 accomplishes the divide by 3 from the logical feedback via $B2_3$. The vertical fields are interlaced as in TV but with 544 lines per frame instead of 525. Division for vertical and slower functions continues through C3, B3 and A3. Wave form diagrams are supplied for horizontal and vertical functions.

7. Video Circuit. Schematic region DB and DD4, C4, Q5.

a.

b. The video mixing circuit picks up the various picture components and mixing occurs at the junction of these mixing resistors. A.C. coupling to the TV is through C40. Q15 inserts H and V sync signals that are forced negative TRUE. This deletes video during sync resulting in a steady picture. A separate input to the video mixing is provided for convenience when testing.

8. Cross hair circuit. Schematic region AA and BB 7,8 and 9.

a. Devices: F1, E1_{6,12}, K7₁₀.

A2_{all}, F2_{all}, J3_{all}, B7_{9,8}, J1, H1, J2₃₋₆₋₁₁, C4₆₋₈, A3₄₋₂,

K1_{all}, N4₇, L3_{all}, K6_{2,12}, M3_{all}, L4, L2, K2, N4₉.

Tilt since - (analog to digital).

Schematic region AA1-2

Devices E8₂, E8₁, F7.

b. Counters L2 and K2 and J1 to H1 are compared to vertical and horizontal timing functions to lines for the cross hairs.

When there is no tilt, the counters are loaded at Pin 11 of the counters. The counters being set to center number generate only straight lines when compared to timing functions. J1 and H1 being compared to horizontal will generate a vertical line when the count number is center. L2 and K2 set to center and compared to vertical functions generates a horizontal line.

When a tilted line is to be generated the counters are preset to ZERO. (Pin 14). While L2-K2 generate the straight horizontal line, the tilted line is essentially horizontal. N4 generates a narrow window in the center of the screen in which the tilted line is to be generated. When this window opens the counter starts to count and it will have counted through to 256 by the time the window closes. If the cross hair tilt is to be to the left, the count pulses are counted UP (J2₆). Thus at the top of the picture the comparator writes a spot at the left of the window. On subsequent lines the comparison is farther and farther to the right. The result is a slanted line.

If the tilt is to be to the right, J2₈ is enabled causing count down. While the counter starts at reset (ZERO), the first count down put it at 256, and we write a line slanting to the left. J1 and J1 generate the horizontal slanting line in an analogous manner, except that the window is a V function and the count H functions. Raw cross hair video is solid when there is no slant. There is no way to avoid dotted lines when there is slant. Therefore, to make the cross hairs consistent F1₁₁,

F1₈, K7₁₀, E1₆, E1₁₂, F1₆ circuits are used to break up the lines for uniform appearance, and to gate out undesired portions.

9. Machine Gun Circuit. Schematic region AA5.
 - a. Devices M7, L7, K7_{all}, M8, L8₄, F7₃.
 - b. Machine gun pulses are developed in counter, M7. V6 is counted (1/60 second). During game time reset is released by trigger. The audio portion of the count is decoded EM and DM at M8₆ (EE8) to operate the speaker. K7_{1,13} - L7₁ decodes a narrow vertical line. L7_{18,4,13} decodes a narrow horizontal line. The AND of these signals at M8₈ gives Bullet Video. Bullet Video is a spot at the center of the screen. There is also a spot at center-bottom but this is to be ignored.

10. Explosion Circuit. Schematic region BB and CC-5 and AA6.
 - a. Devices: N6, M6, M4₃₋₁₁, J4₆, L4₈, K4₆, L8₆, P1_{all}, N1_{all}, M1₆₋₁₂₋₈, L1_{6,9,11}, F6₈, F5₈.
 - b. The explosion is an expanding window in which successively larger blocks blink ON and OFF. The largest WINDOW is WFN3 which is a larger square taken in the center of the display. WFNZ and WFN1 are successively smaller. XFN1 and 2 are broken block functions. The above functions are multiplied in N6 and M6 to give the expanding explosion function.

11. Analog Motion. Schematic region AA and BB1.

a. Devices: Q7, N5₁₀, H8_{1,7}, E8_{14,13}, Q16, Q14, Q12, Q13
and

Random Target Motion Control: Schematic region AA and BB 1 and 2.

Devices A8₃, B8, D8_{all}, N5₂₋₄₋₆₋₈, Q4, Q3, M5₁₂₋₆, N4₄, E1₈, E2₁₋₄.

b. The analog motion circuit outputs at H8₁ and H8₇. The output is in the form of a DC voltage representing position on screen. When this voltage is at about 7.5 volts (reference BB2), the target should be at center of the screen. Comparator E8₁₄₋₁₃ and V-H ramp circuits translate the analog voltage for the digital circuits. The analog voltages are normally always changing. H8 and H8₇ being integrator will continually change in the direction of the input currents.

Input currents are supplied at H8₂ and H8₆ from 3 sources. Source #1 is from the joystick pots and this arrives as the current junction via R50 and R76. Source #2 is random motion. This comes via R68 and R59. Source #3 is via R51 and R77 and this is predominantly bounce components intended to keep the target either on the screen and/or to prevent the integrator from saturating. A saturated integrator would result in a large time delay before the target can be pulled away from the edge of the picture. The bounce circuit is operated by charging or discharging C34 and C33. When the target is moving around in the central area of the picture, the bounce capacitor is charged only through R49 or R75. This is nominally towards ZERO voltage with respect to reference. In other words, towards "no effect". The small effect that these resistors

have is to give motion some inertia to more realistically simulate real airplane behavior. At 1.2 meg, this effect is very small. However, if it is desired to change game characteristics, this could be changed. When the target moves to the edge logic circuits M5₁₂₋₆ and E2₁₋₄ operate N5₄ to N5₈ for charging capacitor or N5₂ to N5₆ for discharging the capacitor. This action either forcefully bounces the target away from the edge or keeps sufficient charge to the capacitor to prevent integrator saturation. If integrator saturation is prevented, random motion summary current will certainly sooner or later push the target back towards center. This is more important in attract than in game because in game the joystick is used to pull the target to the center. Neutral voltage at the joystick pots during game time should be at the reference level, hence giving no motion bias. At mechanical neutral, the resistance on each side of the arm is unbalanced at 1K and 4K. Balance is recovered with on board pots connected on the low resistance side of each joystick control. These pots are used for compensating all game time off center bias. At attract time the control pots are disconnected by conduction of Q7. At this time centering of both horizontal and vertical target motion is done with the 250 ohm attract center pot. Random motion is always imparted to the target by current inputs to the summary junction via R65,64,61,63,66 and 62. For each of horizontal and vertical the values are roughly in the ratio of 4-2-1, giving a D/A conversion of the digital inputs from D8₁. Voltages higher than reference give down or right motion, whereas voltages less than reference give up or left motion. The most significant bit from D8₁₂ or D8₂ is essentially the direction bit. Random digital input to D8 is

obtained from B8 (74164) which is a serial in parallel out 8 bit shift register. The input to the shift register is oscillator A8₃. The shift register is advanced about every 2 seconds. The value that happens to be at the input at shift time is the value that is shifted through the shift register. Since advance time is asynchronous with respect to the free running oscillator, the value at this time is random. As the bit shifts its significance changes allowing the total change instructed to also be random.

12. Digital Motion Circuit. Schematic region DD and EE1.

- a. Devices: D5_{a11}, E5_{a11}, F5₁₂₋₁₀, H5, J5, H6, L5₃.
- b. Prior to a compare of DC input, H8₁ with a ramp at E8₉ the output at E8₁₄ is down. This down condition holds D5₁₃ (latch) up unconditionally. When E8₁₄ rises upon detecting compare, D5₁₃ is enabled to come down, but it will not do so until DT comes down. DT is a negative going signal of 25% duty cycle that is exactly out of phase with MF. Since detection of compare can occur only at a synchronous condition with DT an interface is established from the analog signal which can occur at any time to a synchronous system that has forbidden times.

The negative signal is transmitted through E5₈ to release latch D5₉ and to D5₁. At that time both 1 and 2 of E5 are up giving a negative output at E5₃. This negative condition is quickly terminated when D5₉ is reset by MF.

The overall result is a very short negative pulse guaranteed to occur at compare. This negative pulse resets HT window counters H5 and H6, which count through once. Count is stopped by a down condition at K5. (The most significant bit of the counter). While counting through the target functions are generated. The generation of the vertical target function is completely analogous.

13. Target form circuits. Schematic region DD and EE2.

- a. Devices: $A4_{all}$, $B4_{all}$, $F4_{1,10,4}$, $F1_3$, $C5_{all}$, $A4_{all}$, $A6_8$, $K5_{8-11}$.
- b. Wings, body and fins are ORed at 4, 3, and 5 of C5 respectively. Gate $A6_8$ is disabled during explosion ($A6_{10}$) to cause target to disappear for a moment.

14. Horizon. Schematic region AA and BB2.

- a. Devices: $H8_8$, $H8_{14}$.
- b. The vertical joystick voltage is amplified by $H8_8$ and compared to the vertical ramp with $H8_{14}$. R73 and R74 give hysteresis to smooth transition when a change of direction occurs. The step function generated at $H8_{14}$ is the horizon voltage. The changing voltage at $H8_8$ is used to change motor sound.

G. SETUP PROCEDURE

(1) Instruments Required

- (a) Watch or clock for timing.
- (b) Micronta 22-205A 20,000 ohm/volt meter or equivalent
- (c) Mirror to observe screen while adjustments are made at board.

(2) Motion Centering Adjustment

- (a) Make sure adjustment tabs on each of the joystick pots are centered and secured. We use RTV to secure these tabs.
- (b) Center the joystick mechanically. This should be the position to which spring loading holds the joystick.
- (c) Adjust H balance on board until there is ZERO volts between reference junction R39-R40 and the H control arm. Use a Micronta meter on .5 volt scale.
- (d) Same as (3) except on V joystick pot.
- (e) While meter is connected between V arm and reference, turn game OFF (interrupt power), and adjust ATTRACT center control for ZERO volts.
- (f) Using clip leads short C27 and C24.
- (g) Adjust V and H ramp to center target. Explosions will occur but position can still be observed in at least half of this sequence.

(3) Extended Play Adjustment

The extended play switch is located at P6 on the PCB. It is a 4 pole DIP switch. Each of the poles enables extended play at the skill level of:

1. Wash Out
2. Eagle
3. Student Pilot
4. Ace

Note reversed sequence

If all switches are OFF no extended play occurs. Only one switch should be ON at a time.

(4) Game Time Adjustment

Location: About D6 on board.

Orientation: Face is from top of board.

Adjustment: Clockwise increases game time.

Range: 1/2 minute to 3.5 minutes.

(5) Sound (Volume Control)

Location: About N9

Orientation: Facing is from top of board.

Adjustment: Clockwise to increase volume.

H. PRODUCTION BOARD TESTS

(1) Instruments Required:

- (a) Oscilloscope
- (b) Test station with display and analog controls.

(2) Suggest logical sequence of investigation. A given circuit cannot be assured of work until all that is before it has been confirmed to be functional. (Can be changed as experience dictates).

- (a) Power Supply
- (b) Timing chain to Pix Sync.
- (c) Game Time circuits
- (d) Analog input adjustment
- (e) Confirm proper analog motion as varying DC at H8 1 and 7.
- (f) Confirm H and V ramp at E3 9 and 11.
- (g) Confirm H and V "step" signals at E8 14 and 13.
- (h) Trigger pulse should exit at E5₃ & 11. These pulses are very short and at E5₁₁ may be difficult to see.
- (i) Check for H and V window at H6₆ and L5₂.
- (j) Check for structure of target body through to video.
- (k) Check for proper motion of target in response to control input and random motion input.
- (l) If no random motion check oscillation A8₃ and shift register B8.
- (m) If target sticks check H and V bounce circuits.
- (n) Horizon video.
- (o) Bullet circuits
- (p) Explosion counter L6₅ to N7.
- (q) Explosion video.
- (r) Explosion sounds. If more check audio.

- (s) Motor sounds. If more check audio.
- (t) Audio output.
- (u) Machine gun sounds.
- (v) Cross hair circuits.

NOTES

- (a) R110 on PCB provides a video input point so that circuit may be probed in the video display mode. This point is at E10 and is marked "TP".

- (b) Balance control must be adjusted to match the test station analog controls. See setup procedure. This setup procedure must be repeated later with controls used in actual game.

I. MOTOROLA MONITOR

Monitor circuitry includes four stages of video amplification - a two stage audio amplifier, sync and deflection circuits, and a regulated power supply. An additional 5 volt supply is included to power the external logic system. The rear panel controls work as in any normal T.V. - vertical, horizontal, brightness and contrast. The vertical and horizontal controls should be set in the middle of their range. Turn control until picture tears or rolls, turn control back until picture tears or rolls in the opposite direction and reset control in the middle of the stable range. The brightness and contrast should be set at a point where the images on the screen do not smear. Additional controls are mounted on the printed circuit board (PCB) and are accessible from the rear of the chassis. These include vertical size, vertical linear, focus , etc.

1. Five Volt Supply: This is located on the power, audio PCB which is on the left side of the monitor in back of the power transformer. There is a 1,000 ohm trim pot to adjust the supply voltage. This measurement should be made on the logic PCB to allow for voltage drop from monitor to PCB.
2. Regulator Adjustment: Connect monitor to AC line supply. Adjust horizontal and vertical controls until display is synced. Connect precision voltmeter to any of the 73 volt test points and adjust regulator control R74 on circuit board for an output of 73 volts. CAUTION: Do not run the regulator control through its range or damage to the monitor may result. All that needs to be done is a slight turn to adjust properly. Both the 5 volt and 73 volt adjustments have been made at the factory and under normal

conditions should not need readjustment.

3. The Yoke: The yoke should never need adjustment unless the adjusters have been tempered with or the machine damaged. If yoke adjustment is indicated, adjust both yoke rings simultaneously for optimum centering of the image on the CRT. This adjustment is best handled by a qualified service person.
4. A.C. Voltage Switch: Set this switch to the 115V position ("115" visible on the switch) if the machine is connected to a 115V source or to the 230V position ("230" visible on the switch) if the machine is connected to a 230 volt source. The T.V. monitor will not function if this switch is misadjusted. NOTE: If the monitor of a 230 volt machine is set to 115 volts, it will blow the machine line-fuse repeatedly.
5. The T.V. Monitor Fuse: One 6/10-amp, 250-volt fast-blo fuse protects the T.V. from electrical overload (for 155V operation, the T.V. fuse must be 1-amp fast-blo.) Replace blown fuses with ONLY those which have the above rating. This fuse is located on the electronics mounting board inside the rear door. The fuse furthest from the door is the T.V. fuse, and the fuse nearest the door is the P.C.B. fuse. The P.C.B. fuse should be replaced ONLY with a one-amp, slo-blo, 250-volt fuse.
6. Monitor P.C.B. Removal:
 - (a) Power, Audio PCB: Locate board on the left side of the monitor in back of the power transformer. To remove, pull board up. To replace board, locate the slot between pins 3 and 4 and put this on your left side, then simply insert into the connector.

(b) Monitor PCB: To remove the monitor PCB take a screwdriver or similar object and slowly pry the PCB up off of the chassis until it clears the pins. Next, unplug the socket from the yoke and slide board out. To replace this board, follow the above steps in reverse order.

The monitor can be removed by way of the rear access door of the cabinet. This door also provides access to the logic PCB, transformer assembly, score light PCB and main harness connectors.

CAUTION: Any work performed on monitor chassis should be done only by qualified service personnel who are familiar with servicing procedures and precautions.

J. Q-530 COIN ACCEPTOR: OPERATION, ADJUSTMENT & MAINTENANCE

1. Adjustment: All coin acceptors leave the factory adjusted for maximum performance. If, however, more critical adjustments are desired, or if the unit has been completely disassembled for service, the following adjustment procedure is suggested. If the coin acceptor has been removed from the machine, place it in a vertical position on a level surface. If the acceptor is still mounted on the coin door, place the coin door in a vertical position on a level surface.

Kicker and Separator

1. Set the acceptor with the back of the unit facing you in the test position.
2. Loosen the screws holding the kicker (1) and the separator (3) and move both the kicker (2) and the separator (4) as far to the right as they will go. Tighten the screws.

3. Insert several test coins (both old and new) and note that some are returned by striking the separator.
4. Loosen the separator screw and move the separator a slight amount to the left. Tighten the screw.
5. Insert the test coins again and, if some of them are still returned, repeat Step 4 until all the coins are accepted.
6. Loosen the kicker screw and move the locker as far to the left as it will go. Tighten the screw.
7. Insert the test coins and note that some are returned.
8. Loosen the kicker screw and move the kicker a slight amount to the right. Tighten the screw.
9. Insert the coins again and, if some are still returned, repeat Step 8 until all the coins are accepted.
10. Be sure that both screws are tight after the adjustments have been made.

The Magnet Gate

1. Set the acceptor with the front of the unit facing you in the test position.
2. Turn the magnet gate adjusting screw (2) out (counterclockwise) until none of the coins will fit through.
3. With a coin resting in the acceptor, turn the adjuster in (clockwise) until the coin barely passes through the magnet gate.
4. Test this adjustment using several other coins (both old and new) and, if any of them fail to pass the magnet gate, repeat Step 3 until all the coins are accepted.
5. Fix the magnet gate in this position with a drop of glue or lok-tite, if necessary.

Acceptor Maintenance: Depending on the environment in which the acceptor is used, periodic preventative maintenance should be performed. The mainplate (5) may be cleaned with any household cleaner. Thorough rinsing and drying are necessary to remove deposits and/or film. Remove all metal particles from the magnet by guiding the point of a screwdriver or similar tool along the edges of the magnet. You will notice that the particles will cling to the point of the tool. Remove the transfer cradle (9) and the undersize lever (10) and clean the bushings and the pivot pins. A pipe cleaner is an effective cleaning tool. Apply powdered graphite or pencil lead to the pivot pins and bushings and reassemble. Spray the entire unit lightly with WD-40, a silicone lubricant.

K. GENERAL MACHINE MAINTENANCE

Due to its solid state circuitry, your Pursuit will require very little maintenance other than periodic cleaning, lubrication and T.V. monitor adjustment. The cabinet and plexiglass screen may be cleaned with any non-abrasive household cleaner. The coin acceptor and the rejector linkage should be sprayed lightly once every three months with WD-40 or similar silicone lubricant. The potentiometer shafts must never be lubricated in any way. The T.V. monitor is adjusted only when the CRT picture is distorted, or if the contrast or brightness appear to be out of adjustment.

L. TROUBLESHOOTING

The first step in any troubleshooting procedure is to identify the observable characteristics of the malfunction. With these clues in mind, examine the areas of the machine which might cause these symptoms. For example, if there is no power, check the harness - not the PCB. Likewise, if part of the playfield display is missing, check the PCB - not the harness or TV.

Three major areas of the machine can be isolated for troubleshooting purposes: the T.V., the PCB and the harness. The harness includes the fuses, the transformer, the interlock switches, the A.C. line filter, the start and coin switches, the antenna wire, the potentiometers, all plug-in type connectors, the PCB edge connector and all the interconnecting wires.

1. Substitution: Substitution of parts is a legitimate and easy way to troubleshoot the machine. For instance, if you suspect PCB malfunction try substituting another and known-to-be-good PCB. To check the T.V. monitor by substitution, connect the malfunctioning game to a known-to-be-good monitor. Harnesses are checked by elimination. Substitute a good T.V. and PCB and if the malfunction persists, the harness must be at fault.
2. Other Troubleshooting Tips: If you have a T.V. raster only (a T.V. raster is a blank, but lit T.V. screen with the brightness turned all the way up) and you want to determine if it is the PCB or the T.V. that is causing the lack of video display, try the following test: (A) disconnect the PCB edge connector; (B) turn the brightness and contrast all the way up; (C) connect pin 11 of the PCB edge connector to pin 12 with a test lead. If

your T.V. monitor is functioning correctly, you will see faint black bars ("hum bars") on the screen.

TO CHECK THE SPEAKER, turn the volume control all the way up, and connect one end of a test lead to pin 2 (audio) of the disconnected PCB edge connector. Momentarily touch the other end to either pin 3 or pin 4 (transformer secondary AC) of the edge connector and if the speaker is functioning correctly, you will hear a loud buzz (60 cycle hum). To check if the TV POWER SUPPLY is functioning correctly, use the following procedure: check the T.V. power supply output between pin 6 and pin 8 with a VOM. Meter should read 5 volts DC.

3. Troubleshooting by Symptom:

1. NO POWER: a. check for correct line voltage and if OK then check fuses and interlock switches. If OK, check transformer primary which should show line voltage. Then check transformer secondary (pins 19 and 21) which should be 10 VAC.
2. GAME CREDIT SHUTS OFF: Try cutting the antenna wire shorter in increments of 1-2 inches.
3. GAME CREDIT SHUTS OFF AND/OR T.V. PICTURE SHRINKS: Check line voltage with VOM and be aware that a large motor nearby (e.g. air conditioner) may drop line voltage when starting up.
4. NO PICTURE; NO RASTER: Check to see if T.V. connector is plugged in; check for line voltage at T.V. and if T.V. AC voltage switch is set to correct position. Check T.V. fuses and brightness control.
5. T.V. RASTER ONLY: Check harness and especially the PCB edge

- connector. Check PCB. Check T.V.
6. PICTURE ROLLS: Adjust T.V. vertical hold. Check or replace PCB.
 7. PICTURE IS WAVY: Adjust T.V. horizontal hold. Replace transformer. Check harness, particularly grounds.
 8. PICTURE IS BROKEN INTO DIAGONAL LINES: Adjust T.V. horizontal hold. Replace PCB.
 9. JERKY PLANE MOTION: Replace appropriate potentiometer.
 10. NO GAME CREDIT: Check coin switch and harness. Replace PCB.
 11. GAME SEQUENCE INCORRECT OR PARTS OF PLAYFIELD DISPLAY MISSING, DISTORTED OR NOT FUNCTIONING: Replace PCB.
 12. NO AUDIO: Check volume control, speaker connections.
Replace PCB.

DIAGNOSIS:

SYMPTOM

CHECK

No picture	Power cord, harness connections, line and monitor fuses.
No sound	Speaker connections, volume adjustment
Rolling or tearing picture	Readjust T.V. controls
White picture but no display	Edge connector on logic PCB, 5 volt supply from monitor, 12 pin Molex connector on monitor.
Wavy Picture	5 volt supply, 73 volt regulator adjustment
Game will not start	Coin mechanism, harness connections
No Firing	Joystick, harness connections

NOTE: If the above checks do not solve the problem, consult the appropriate theory of operation description of the logic PCB circuits.

M. P.C.B. SHIPPING

Careful packing of PCBs and other parts being returned is recommended as we cannot be liable for items damaged in transit. If possible, include a short statement describing the problem encountered with the game.

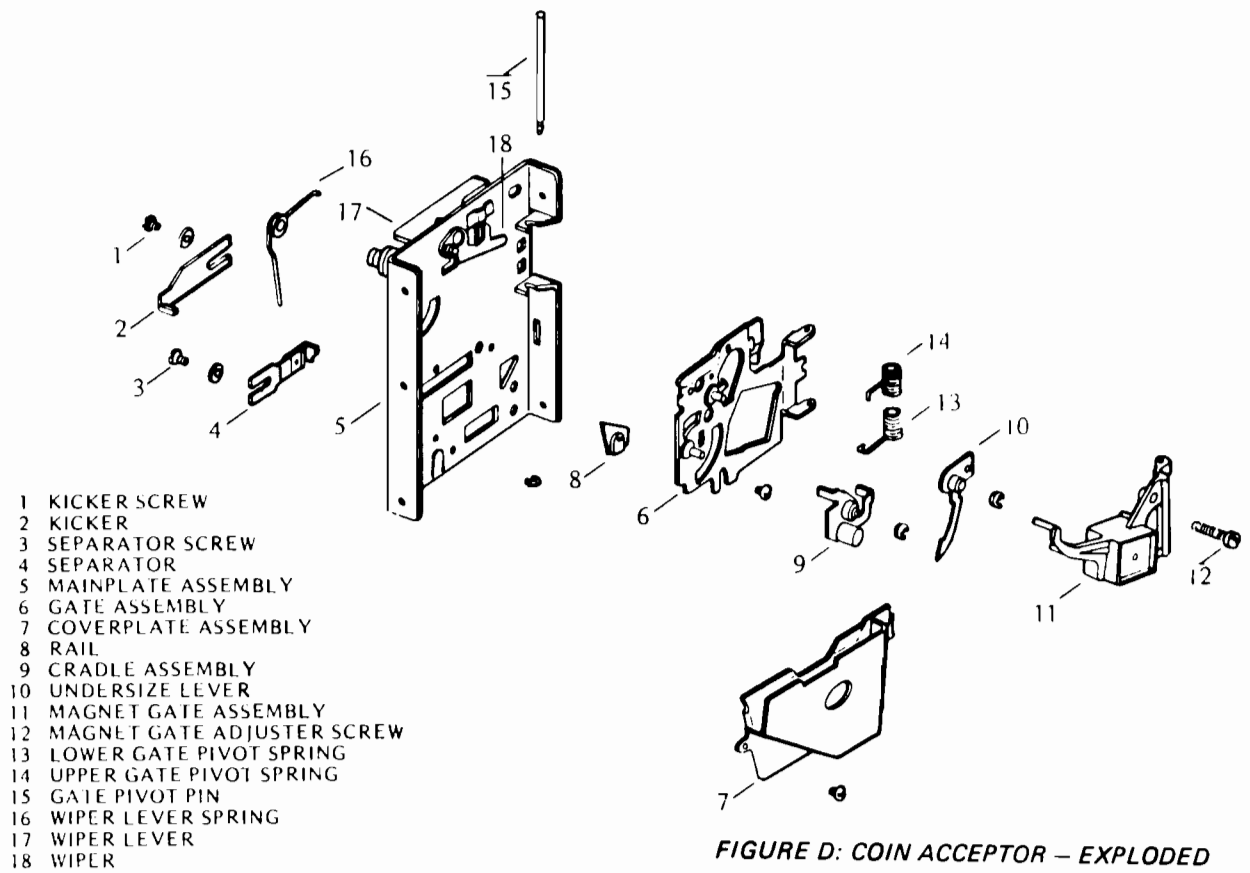

FIGURE D: COIN ACCEPTOR – EXPLODED

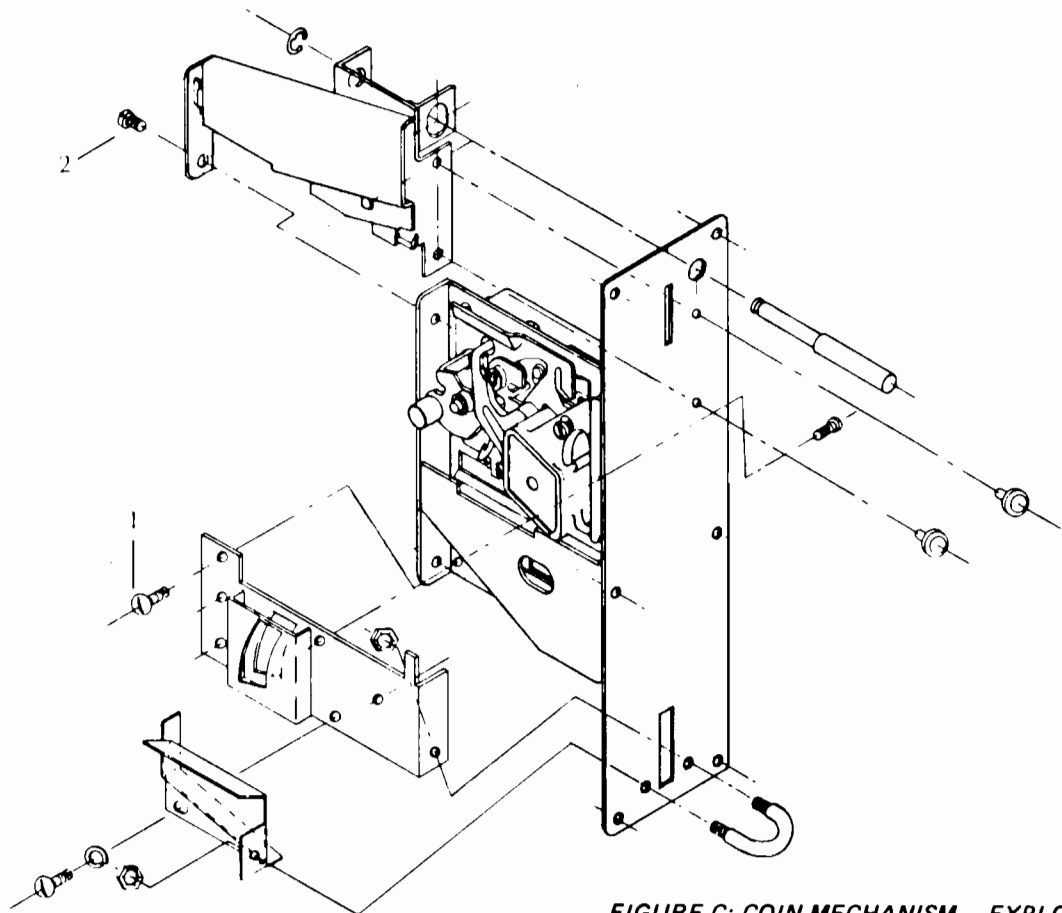

FIGURE C: COIN MECHANISM – EXPLODED



ASSEMBLY TITLE / FINAL ASSY - JOYSTICK P/L A002780

PARTS LIST SPECIFICATION Page 1 of 1

Drawn	
Checked	Mech. Eng. <i>[Signature]</i>
Proj. Eng. <i>[Signature]</i>	Elec. Eng. <i>[Signature]</i>
	REV. B

Rev.	Description	Date	Apprv.	Rev.	Description	Date	Apprv.
A	<i>[Handwritten]</i>						
B	<i>[Handwritten]</i>	<i>[Handwritten]</i>	<i>[Handwritten]</i>				

Item	Part Number	Qty.	DESCRIPTION
1	A002780	Ref	Joystick - Final Assy
2	A002783	1	Shaft Weld Assy
3	002784	1	Mounting Plate
4	002809	1	Stop
5	002786	1	Mounting Bracket
6	A002781	1	Kraft joystick Assy
7	73-02-08	1	Cotter Pin 1/8 dia x 1/2 long
8	78-2622	1	Grommet
9	71-5203	1	Links of chain - Stl, Single Jack #12- 2-1/2" long
10	75-666	4	Sheet Metal Screw #6 - 3/8 long
11	75-5616A	2	Carriage Bolt 5/16-18 x 1
12	75-991102	2	Nut 5/16- 18
13	75-043	2	Split Lock Washer - 5/16"
14	75-5512N	2	Carriage Bolt 1/4-20x3/4
15	75-915S	2	Nut 1/4-20
16	75-045	2	Lock Washer 1/4



ASSEMBLY TITLE / PURSUIT CABINET FINAL ASSY P/L A002869

PARTS LIST SPECIFICATION Page 1 of 1

Drawn *[Signature]*
 Checked *[Signature]* Mech. Eng. *[Signature]*
 Proj. Eng. *[Signature]* Elec. Eng. TJE
 REV. C

Rev.	Description	Date	Apprv.	Rev.	Description	Date	Apprv.
A	Production Release	12-27-74	<i>[Signature]</i>				
B	Per ECN = 1028	12-27-74	<i>[Signature]</i>				
C	Rev per ECN 1054	1-13-75	<i>[Signature]</i>				

Item	Part Number	Qty.	DESCRIPTION
1	A002869	Ref	Cabinet Final Assy
2	A002804	1	Cabinet
3	A002882	1	Upper, Formed Panel Assy
4	A002870	1	Flourescent Light Assy
5	A002871	1	T.V. Mounting Assy
6	A002780	1	Joystick Assy
7	A002878	1	Double Coin Switch Assy
8	73-7401	10	Southco Rivet #38-106-30-13
9	75-5520N	4	Carriage Bolt 1/4-20 x 1-1/4
10	75-015S	4	Plain Washer 1/4"
11	75-045	4	Lock Washer 1/4"
12	75915S	4	Hex Nut 1/4-20
13	75-5132N	6	Carriage Bolt #10-24 x 2"
14	75-911S	6	Hex Nut #10-24
15	75-0146	6	Plain Washer #10
16	75-040	6	Lock Washer #10
17	A002807	1	Harness (Sub)
18	A002808	1	Harness (Main and Sub)
19	A002879	1	PCB Tray Assy
20	75-2124S	2	R.Hd. Mach. Screw #10-24 x 1-1/2
21	75-911S	2	Hex Nut #10-24
22	75-014C	4	Flat Washer #10
23	75-050	2	Lock Washer #10
24	75-7606	1	Sht. Metal Screw Pan Hd. Phil. #6 x 1"

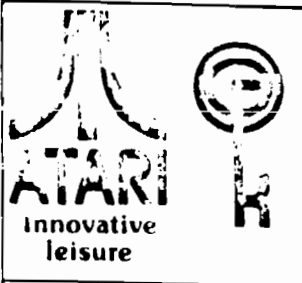

ASSEMBLY TITLE / PURSUIT P/L 002490

PARTS LIST SPECIFICATION Page 1 of 3

Drawn *[Signature]* 12-12-74
 Checked *[Signature]* Mech. Eng.
 Proj. Eng. *[Signature]* Elec. Eng
[Signature] 7 01/3/77
 REV. D

Rev.	Description	Date	Apprv.	Rev.	Description	Date	Apprv.
B	PROD 1	12-17-74					
C	Rev per ECN 1021, 1034, & 1035	1-8-75					
D	REV PER ECN 1057, 1072						

Item	Part Number	Qty.	DESCRIPTION
1	37-7400	10	I.C. 7400
2	37-7402	5	I.C. 7402
3	37-7404	9	I.C. 7404
4	37-7405	4	I.C. 7405
5	37-7406	2	I.C. 7406
6	37-7410	5	I.C. 7410
7	37-7420	3	I.C. 7420
8	37-7427	2	I.C. 7427
9	37-7442	1	I.C. 7442
10	37-7474	1	I.C. 7474
11	37-7486	13	I.C. 7486
12	37-7493	13	I.C. 7493
13	37-74107	4	I.C. 74107
14	37-74132	1	I.C. 74132
15	37-74153	2	I.C. 74153
16	37-74164	1	I.C. 74164
17	37-74193	4	I.C. 74193
18	37-74279	3	I.C. 74279
19	37-555	2	I.C. 555
20	37-741	1	I.C. 741
21	37-LM339	1	I.C. LM339
22	37-LM324	1	I.C. LM324
23	37-3080	1	I.C. 3080 RCA
24	37-LM309K	1	I.C. LM309K
25	37-LM380	1	I.C. LM380
26	10-02P7	1	Resistor, 27 ohm, 1/4 watt, 10%R125
27			
28	10-0220	1	" 22 " " " " R101
29	10-0101	1	" 100 " " " " R120
30	10-0181	2	" 180 " " " " R37,54
31	10-0221	2	" 220 " " " " R39,86,
32	10-5331	2	" 330 " " " " 5%R39,R40
33	11-5331	1	" 330 " 1/2 " 5%R112
34	10-0331	3	" 330 " 1/4 " 10%R3,R2
35	10-0471	8	" 470 " " " " R97,R32,R83,R84,81, 109,110,111
36	10-0561	4	" 560 " " " " R79,94,60,67
37	10-0102	14	" 1K " " " " R107,38,10,104,85,27, 28,1,18,55,90,15,,124,80
38	10-0563	2	" 56K " " " " R21,23
39	10-0122	7	" 1.2K " " " " R70,71,57,58,69,78,56

PARTS LIST SPECIFICATION

Item	Part Number	Qty.	DESCRIPTION	Rev	D
39	10-0222	5	Resistor, 2.2K ohm, 1/4 watt,10%,	92,	,16,
40	10-0272	10	" 2,7K " " " " "	9,108,105	
41	11-5221	1	" 220 " 1/2 " 5% R113		
42	10-0392	1	" 3 9K " 1/4 " 10% R119		
43	10-0472	3	" 4.7K " " " " "	R93,102,103	
44	10-0562	5	" 5.6K " " " " "	R47,91,	,118
45	10-0682	1	" 6.8K " " " " "	49,72	
46	10-0822	1	" 8.2K " " " " "	R11	
47	10-0103	8	" 10K " " " " "	R117	
48	10-0153	4	" 15K " " " " "	R87,83,106,96,98,	99, 43,73
49	10-0223	3	" 22K " " " " "	R68,19,22,59,	
50	10-0333	5	" 33K " " " " "	R13,R24,R26	
51	10-5563	2	" 56K " " " 5% R46,R44		
52	10-0823	1	" 82K " " " 10% R53		
53	10-0104	5	" 100K " " " " "	R29,30,51,77,121	
54	10-0154	2	" 150K " " " " "	R7,R8	
55	10-0474	2	" 470K " " " " "	R33,34	
56	10-0394	2	" 390K " " " " "	R50,76	
57	10-0564	2	" 560K " " " " "	R122,R14	
58	10-0684	1	" 680K " " " " "	R4	
59	10-0105	4	" 1 meg " " " " "	R53,65,6,5	
60	10-0125	2	" 1.2 " " " " "	R75,49	
61	10-0225	2	" 2.2 " " " " "	R64,66	
62	10-0395	2	" 3.9 " " " " "	R62,61	
63	34-2N3643	12	Transistor, NPN, 2N3643		
64	34-2N3644	6	" PNP, 2N3644		
65	31-1N914	6	Diode, 1N914		C26,27, 12
66	31-1N4001	5	Diode, 1N4001		C4,21,20,38,
67	27-120104	17	Capacitor, .1uf, +80%,-20% Ceramic		C19,23,22,47,2,
68	29-008	2	" " +20%, 12 volts,C24,C28		C15,16,9,3,25,
69	27-250104	3	" " +80%,-20%,25volts,C41,46,8		
70	27-101103	6	" .01uf,+80,-20%,Cer,C17,1,30,35,15,14		
71	29-009	3	" .001uf,±10%,100v,C32,C11,7		
72	21-101224	2	" .22uf,±10%,Mylar, C31,29		
73	28-101221	1	" 220pf, Ceramic Disc,10%,C5		
74	28-101101	1	" 100pf, Ceramic Disc,10%, C45		
75	24-250475	1	" 4.7uf,25v, ±10%, Electrolytic, C6		
76	24-250106	4	" 10uf,25v,Electrolytic,C10,33,34,18		
77	24-060105	3	" 1uf,25v, Electrolytic,C44,36,37		
78	24-250506	1	" 50uf, 25v, Electrolytic,C40		
79	24-250507	1	" 500uf, 25v, " ,C48		
80	24-060107	1	" 100uf, 6v, " ,C39		
81					
82	24-250478	1	" 4700uf, 25v,GMV Nichicin N7419 or equiv. C42		
83					
84					
85	19-311105	1	Pot, 1 meg, CTS x201 R105B		

PARTS LIST SPECIFICATION

Page 3 of 3

Item	Part Number	Qty.	DESCRIPTION	Rev	D
85	19-311502	4	Pot, 5K, CTS x201R502B		
86	19-311104	1	Pot, 100K, CTS x201R104B		
87	66-02	1	Dip Switch, Molex 4130 #01-70-0104		
88	19-311251	1	Pot, 250		
89	002743	1	Crystal 12.096 MHz		
90	75-2601S	2	Screw, 6-32 x 5/8", Pan Hd., S.S.		
91	75-056	2	Washer, Internal Star Lock, #6		
92	75-016S	2	Washer, Flat		
93	75-916S	2	Nut, Hex, 6-32		
94	12-0101	1	Resistor, 100 ohm, 1 watt, 10%		
95	38-MV5013	1	LED, MV5013		
96	10-0274	1	Resistor, 270 K ohm, 1/4 watt, 10%		

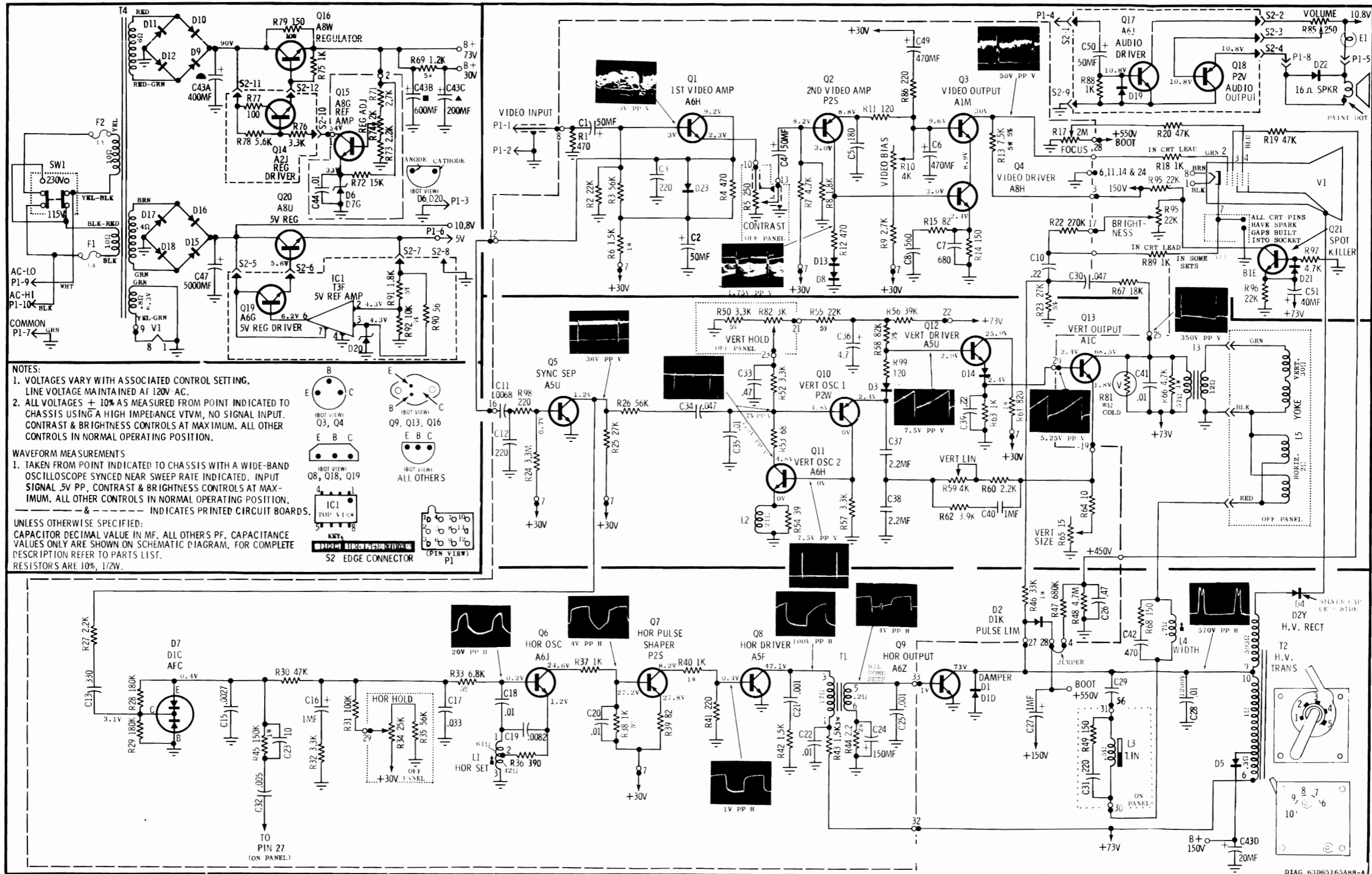

NOTES REVISED
 NOTE ADD TO R86 & C5
 C7 WAS 270
 D22, D21, D14 ADDED.
 C49 & R86 REVERSE ORDER IN CKTRY
 C31 & R49 REVERSE ORDER IN CKTRY
 WAVE FORM PP VOLTAGE
 CHANGED AT Q68, T2 PIN 9, 10
 C1, C2, C4 WERE 47MF
 VOLTAGES REVISED - Q2, Q4, Q3
 VOLTAGES ADDED TO Q15, Q19,
 IC1, Q17, Q19
 RESISTANCES ADD TO
 T4, R81, L5, T2, L4, T1, L2

0 RELEASED FOR REPRODUCTION
 ISSUE RELEASES AND REVISIONS MIMO
 DRAWN BY DATE COLLECTED BY DATE
 6335 1-22-71
 DMC APPR BY DATE SPEC BY

MOTOROLA
 AUTOMOTIVE PRODUCTS
 CONSUMER PRODUCTS
 FRANKLIN PARK, ILL. 60131

PART NAME: XM501-10
 XM701-10
 DIAGRAM SCHEMATIC

DESIGNED BY: BLUMHETTER
 TRAC PROJ NO: 19V111 23VD111

NUMBER: 63D65165A88

SYM	DESCRIPTION	DFTG	APPV.
C	REV PER ECN 1021, 1034, 1035	8/9	[Signature]
D	REV PER ECN 1067, 1072	8/9	[Signature]

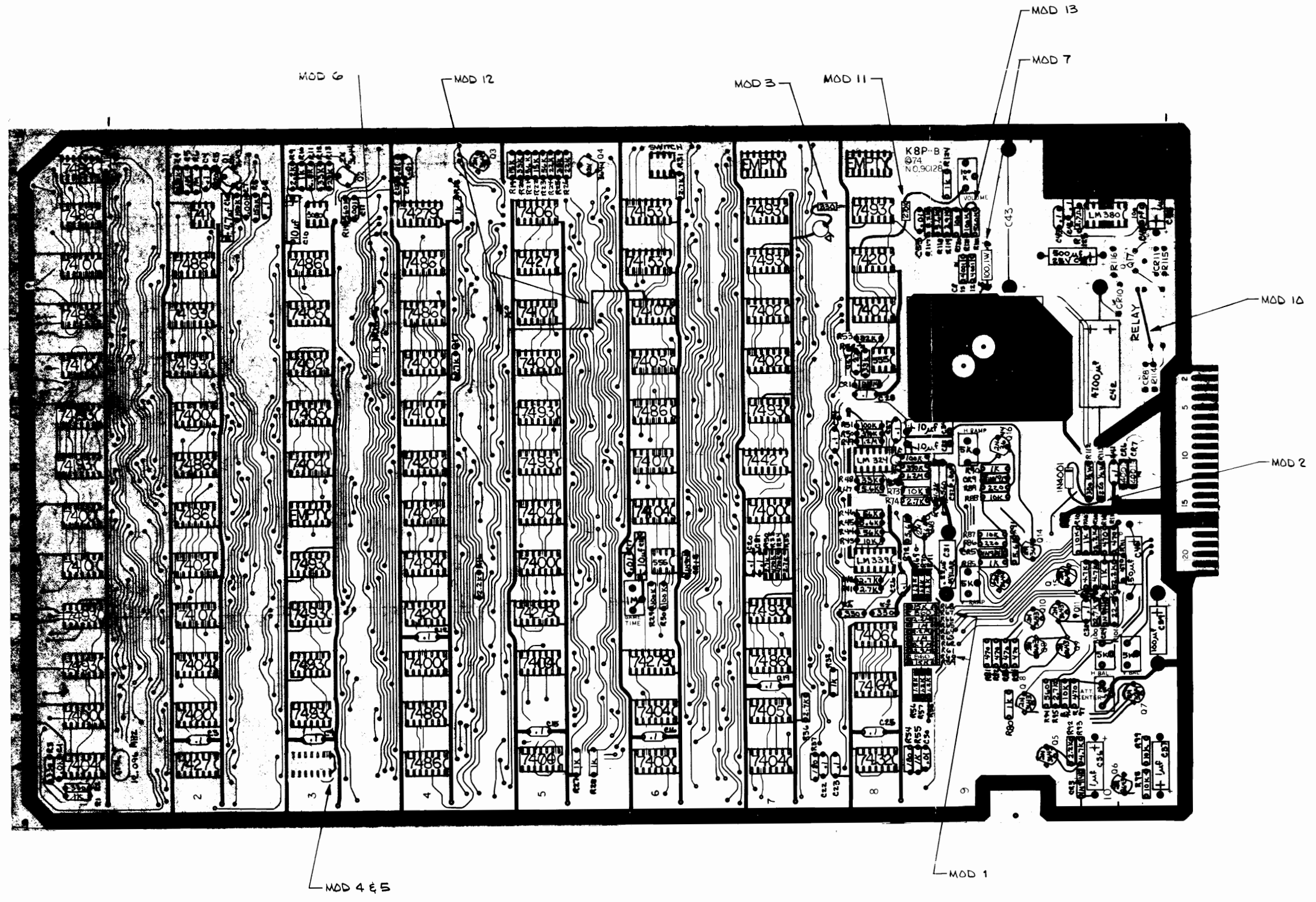

MODIFICATIONS:

1. CHANGE R60 & R67 FROM 5.6K TO 560Ω.
2. ADD 1N4001 BETWEEN +15V & +5V, CATHODE TO +15V.
3. ADD LED IN SERIES WITH 330Ω RESISTOR BETWEEN +5V & GND.
4. DELETE I.C. A3 (7493).
5. JUMPER PIN 1 TO PIN 14 ON A3 I.C. PATTERN.
6. CHANGE R15 FROM 2.2K TO 1K.
7. ADD 100Ω, 1W RESISTOR IN EXISTING HOLES NEXT TO CR12.
8. DELETE HEATSINK FROM LM309.
9. DELETE THE FOLLOWING COMPONENTS:
 - A. C43 - 250μf
 - B. Q17 - 2N3643
 - C. CR10 - 1N914
 - D. CR11 - 1N4001
 - E. CR8 - 1N914
 - F. R116 - 1K
 - G. R114 - 15Ω
 - H. R115 - 100Ω
 - I. L10 - RELAY
10. ADD JUMPER BETWEEN WIPER AND N.C. OF RELAY PATTERN.
11. ADD 270K RESISTOR FROM MB PIN 6 TO C.W. SIDE OF 100K POT.
12. CUT TRACE, AS SHOWN, ADJACENT TO K5 & L5. RUN JUMPER FROM TRACE TO I.C. L6 PIN 5.
13. JUMPER LEADS OF R121 & R122 NEAREST 100K POT.

K8P-A PURSUIT REV. D
 KEE GAMES INC. ASSY.
 14600 WINCHESTER BLVD.
 LOS GATOS CA. 95030
 (408) 374-2440

SCALE: 1/1 APPROVED: [Signature]
 DATE: 11-7-74
 P. BRISTOW
 DRWG. NO. A002490

REV.	DESCRIPTION	DRAWN	CHECKED	APPROVED
A	PROD. RELEASE			
B	FOR ECN 1066		1/15/75	

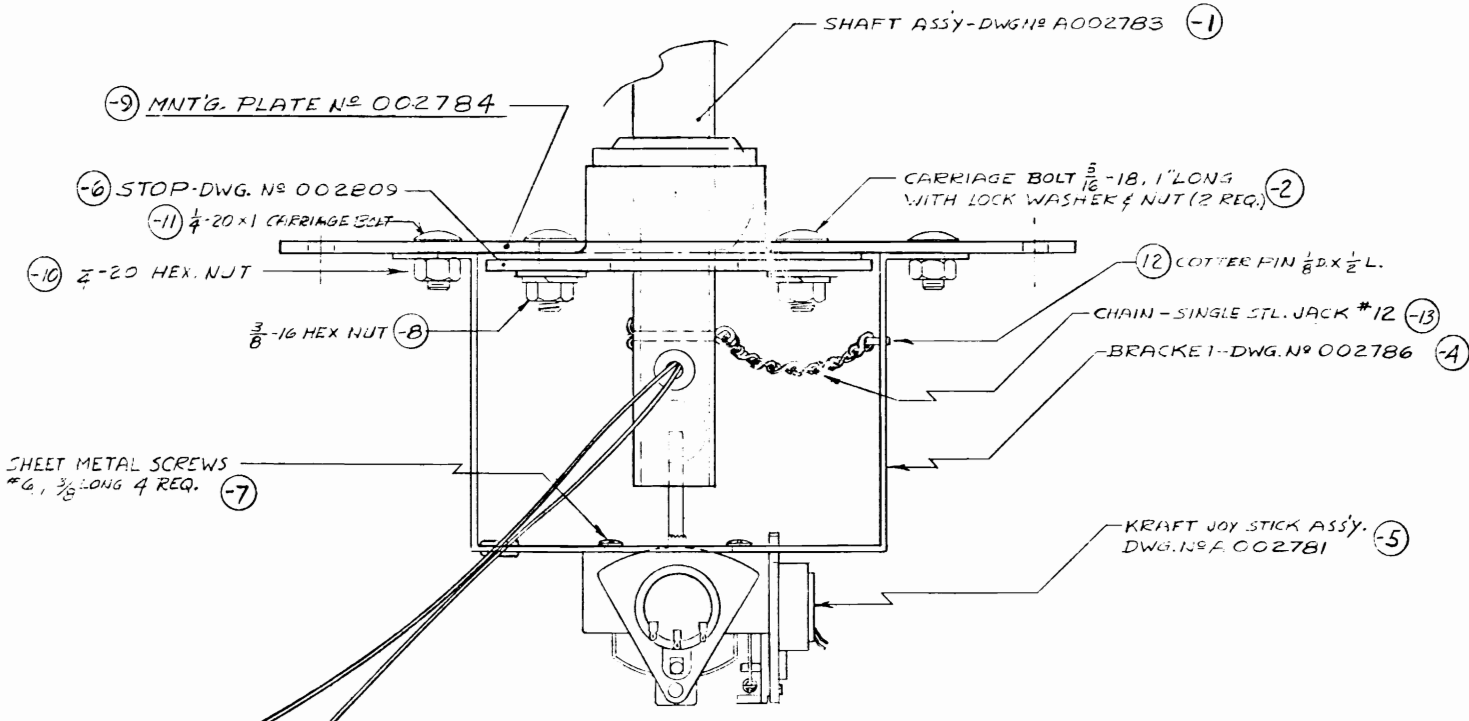
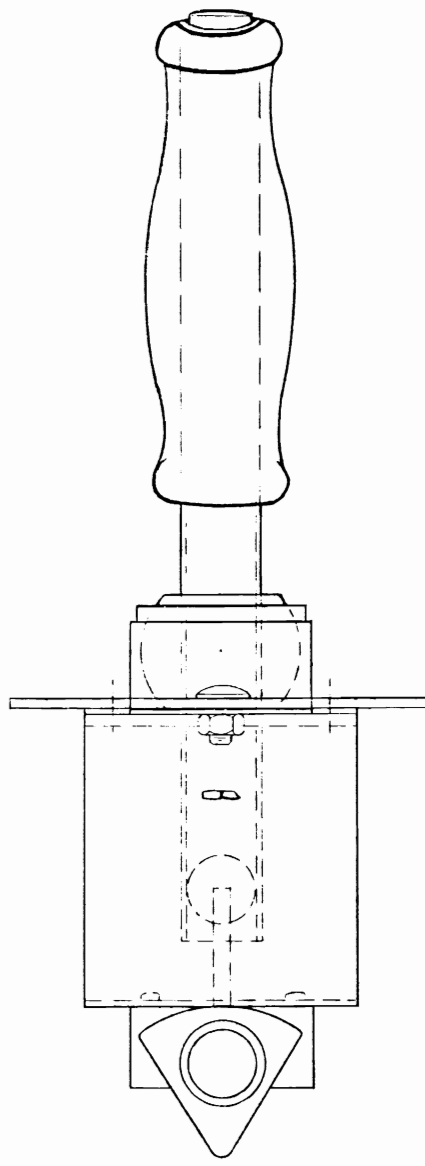
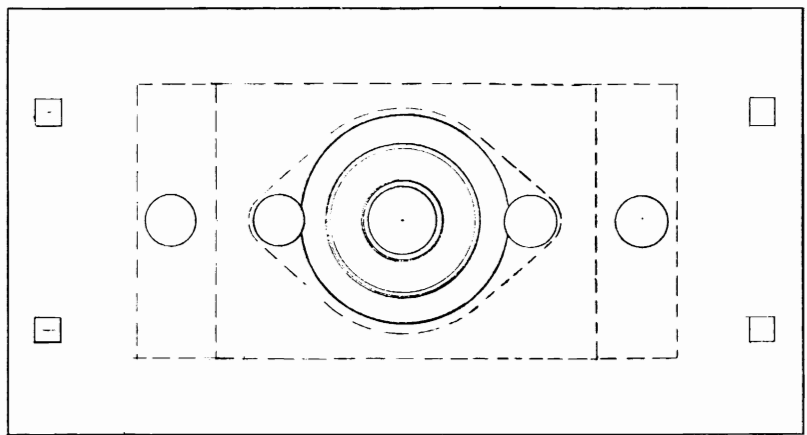

NOTE:
 INSERT WH-RED WIRE INTO PIN #1 HOLE &
 WH-BLU WIRE INTO #5 HOLE
 JOY STICK HARNESS A002807-04
 JOY STICK WIRE DETAIL DWG. A002807-03

BACK VIEW

SIDE VIEW

ECN 1083
1-22-75 N. Wolff
HISTORY PRINT

QTY	DESCRIPTION	UNIT
1	CHAIN-SINGLE STL. JACK #12	QTY
1	COTTER PIN 1/8 DIA. X 1/2 L.	
2	1/4-20 X 1 CARRIAGE BOLT	
2	1/4 LOCK WASHER	
2	1/2-20 HEX NUT	
1	MNT'G PLATE	
2	LOCK WASHER - 5/16	
2	HEX NUT 5/16-18	
4	SHEET METAL SCREW 1/8 X 3/8 L.	
1	STOP	
1	KRAFT JOY STICK MODIFICATION	
1	BRACKET	
2	CARRIAGE BOLT 5/16-18 X 1	
1	SHAFT ASS'Y.	
	DWG. NO.	DESCRIPTION

KEE GAMES

SCALE:	APPROVED BY:	DRAWN BY:
DATE:	<i>7/1/75</i>	REVISED <i>1/15/75</i>
PURSUIT		
FINAL ASSY.-JOY STICK		DRAWING NUMBER
		A002730

REVISIONS				
SYM	DESCRIPTION	INITIALS and DATE		
		DRFTG	CHECK	ENGRG

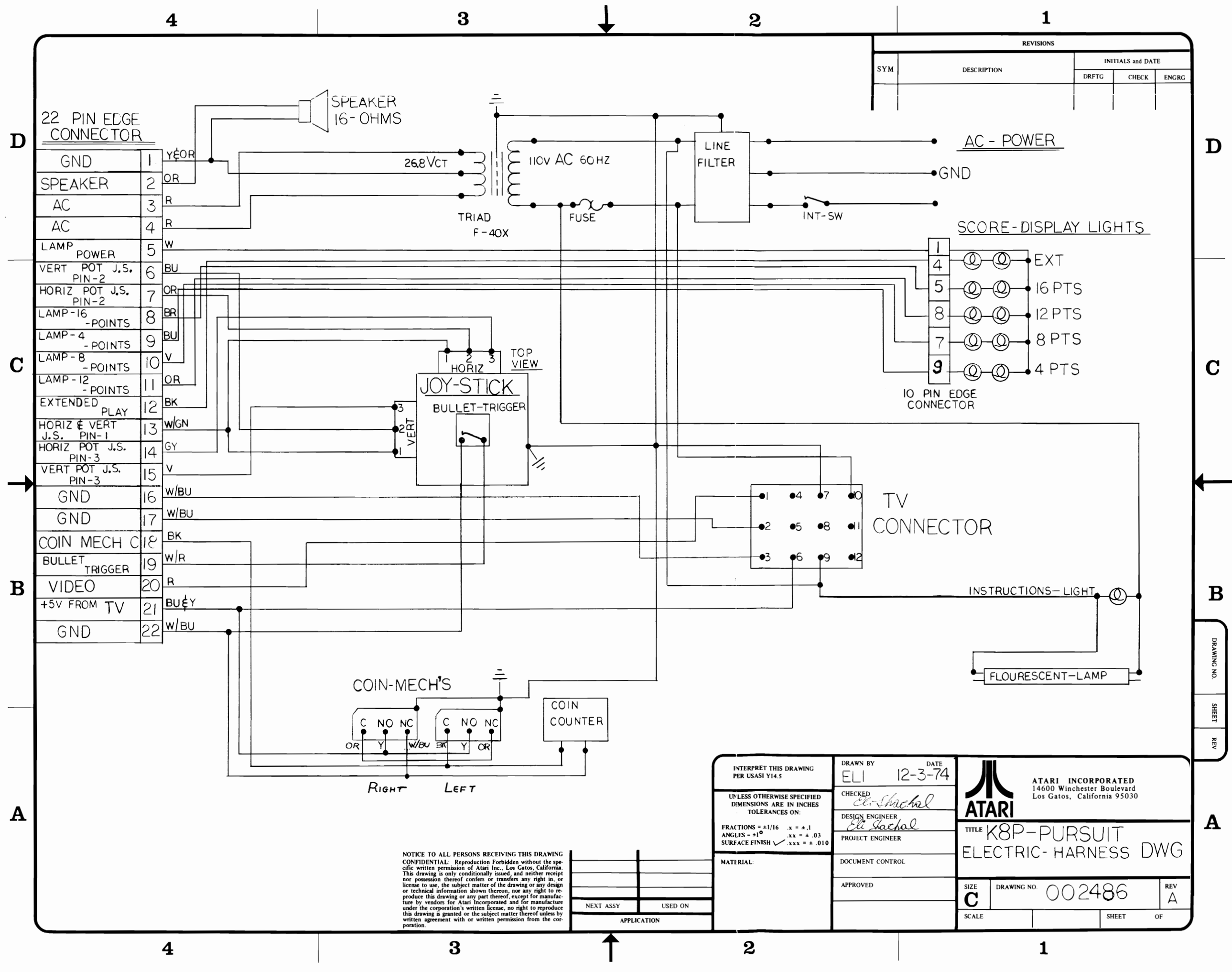

NOTICE TO ALL PERSONS RECEIVING THIS DRAWING
 CONFIDENTIAL: Reproduction Forbidden without the specific written permission of Atari Inc., Los Gatos, California. This drawing is only conditionally issued, and neither receipt nor possession thereof confers or transfers any right in, or license to use, the subject matter of the drawing or any design or technical information shown thereon, nor any right to reproduce this drawing or any part thereof, except for manufacture by vendor for Atari Incorporated and for manufacture under the corporation's written license, no right to reproduce this drawing is granted or the subject matter thereof unless by written agreement with or written permission from the corporation.

APPLICATION	USED ON	NEXT ASSY

INTERPRET THIS DRAWING PER USASI Y14.5	DRAWN BY ELI	DATE 12-3-74
UNLESS OTHERWISE SPECIFIED DIMENSIONS ARE IN INCHES TOLERANCES ON:	CHECKED <i>Eli Sachal</i>	DESIGN ENGINEER <i>Eli Sachal</i>
FRACTIONS = +1/16 .x = .1 ANGLES = ±1° .xx = .03 SURFACE FINISH ✓.xxx = .010	PROJECT ENGINEER	DOCUMENT CONTROL
MATERIAL:	APPROVED	

ATARI INCORPORATED
 14600 Winchester Boulevard
 Los Gatos, California 95030

TITLE **K8P-PURSUIT
 ELECTRIC-HARNES DWG**

SIZE **C** DRAWING NO. **002486** REV **A**

SCALE SHEET OF

DRAWING NO.
SHEET
REV

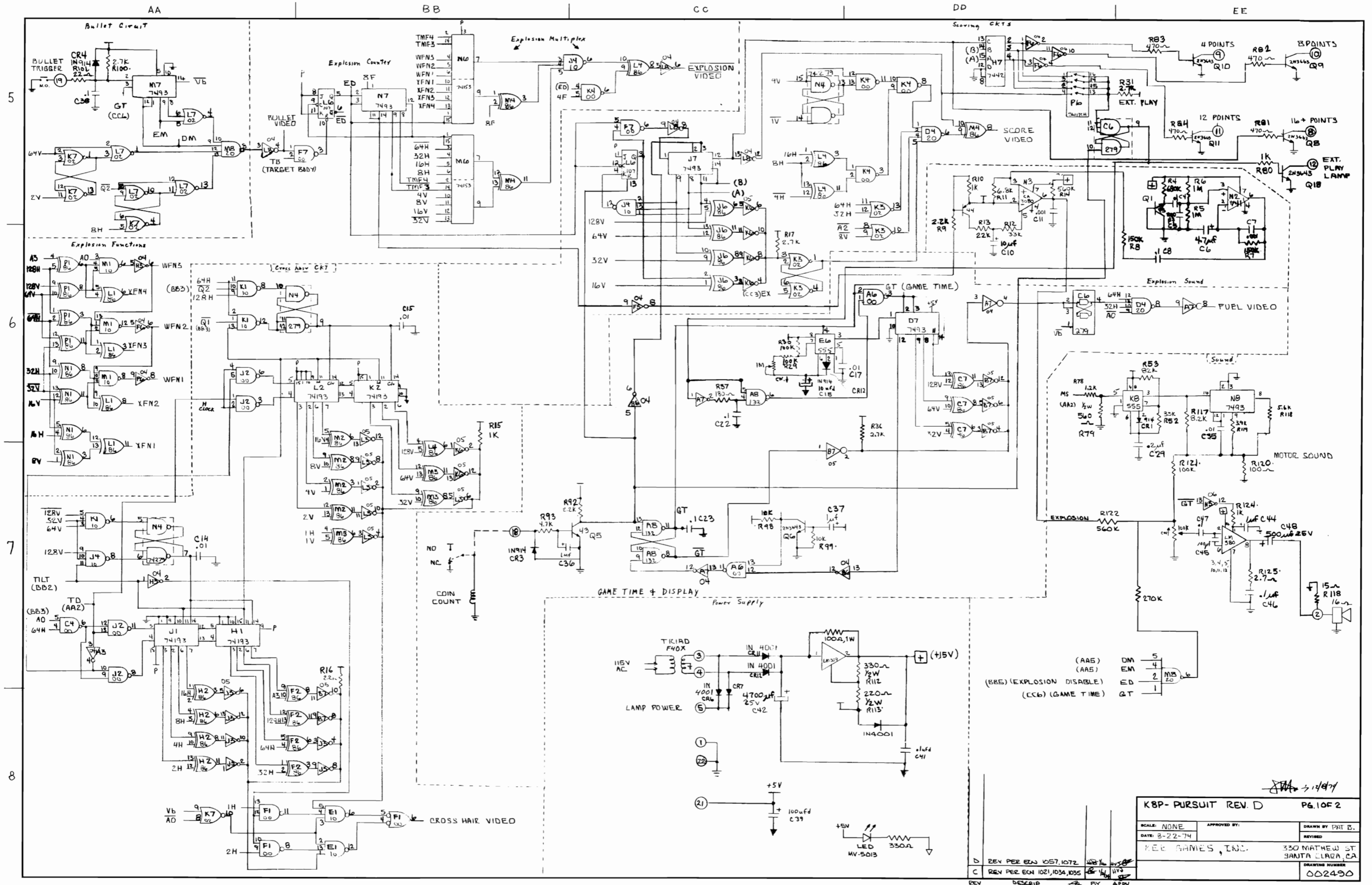

1/14/77

KBP- PURSUIT REV. D		P6.10F2
SCALE: NONE	APPROVED BY:	DRAWN BY: PAT B.
DATE: 3-2-74		REVISED:
K&E GAMES, INC.		350 MATHEW ST SANTA CLARA, CA
DRAWING NUMBER		002490

D REV PER ECU 1057,1072
 C REV PER ECU 1021,1034,1035
 REV DESCRIP BY APPV

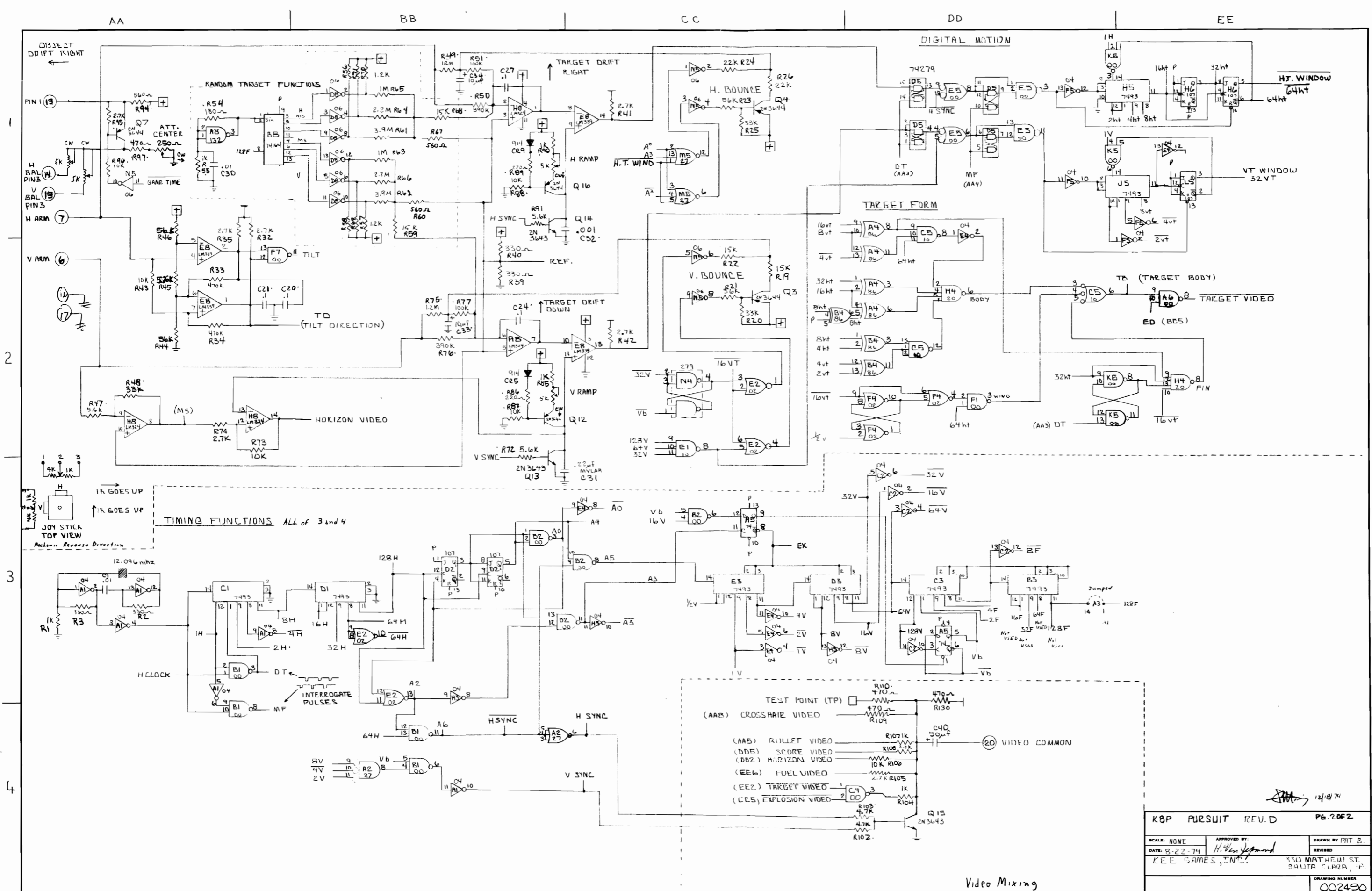

K8P PURSUIT REV. D		PG. 2 OF 2
SCALE: NONE	APPROVED BY: <i>H. Van Dyke</i>	DRAWN BY: PAT B.
DATE: 8-22-74		REVISED
K.E.E. GAMES, INC.		350 MATHEW ST. SAULT CLAIR, MI.
DRAWING NUMBER		002490

Video Mixing

