

GAME NOS. 961, 962 & 963
JUNE, 1981

MIDWAY'S

WIZARD OF WOR

PARTS AND

OPERATING MANUAL



#963-MINI

#962-COCKTAIL

#961-UPRIGHT



MIDWAY MFG. CO.

A BALLY COMPANY

10750 WEST GRAND AVENUE
FRANKLIN PARK, ILLINOIS 60131
U.S.A.

PHONE: (312) 451-1360

CABLE ADDRESS: MIDCO

TELEX NO.: 72-1596

WARNING

**THIS GAME MUST BE GROUNDED. FAILURE TO DO SO MAY
RESULT IN DESTRUCTION TO ELECTRONIC COMPONENTS.**

COPYRIGHT 1981 ©BY MIDWAY MFG. CO. ALL RIGHTS RESERVED.

NO PART OF THIS PUBLICATION MAY BE REPRODUCED BY ANY MECHANICAL, PHOTOGRAPHIC, OR ELECTRONIC PROCESS, OR IN THE FORM OF A PHONOGRAPHIC RECORDING, NOR MAY IT BE TRANSMITTED, OR OTHERWISE COPIED FOR PUBLIC OR PRIVATE USE, WITHOUT PERMISSION FROM THE PUBLISHER.

FOR PERMISSION REQUESTS, WRITE: MIDWAY MFG. CO., 10750 W. GRAND AVE., FRANKLIN PARK, IL 60131

WARNING: This equipment Generates, Uses and can Radiate Radio Frequency Energy and if not installed and used in accordance with the Instructions Manual, may cause interference to Radio Communications. As temporarily permitted by Regulation it has not been tested for compliance to Subpart J or Part 15 of FCC Rules, which are designed to provide reasonable protection against such interference. Operation of this equipment in a Residential Area is likely to cause interference in which case the user at his own expense will be required to take whatever measures may be required to correct the interference.

ELECTRICAL BULLETIN: FOR ALL APPARATUS COVERED BY THE CANADIAN STANDARDS ASSOCIATION (CSA) STANDARD C22.2 NO. 1, WHICH EMPLOYS A SUPPLY CORD TERMINATED WITH A POLARIZED 2-PRONG ATTACHMENT PLUG.

CAUTION: TO PREVENT ELECTRIC SHOCK DO NOT USE THIS (POLARIZED) PLUG WITH AN EXTENSION CORD, RECEPTACLE OR OTHER OUTLET UNLESS THE BLADES CAN BE FULLY INSERTED TO PREVENT BLADE EXPOSURE.

ATTENTION: POUR PREVENIR CHOCS ELECTRIQUES NE PAS UTILISER CETTE FICHE POLARISEE AVEC UN PROLONGATEUR. UNE PRISE DE COURANT OU UNE AUTRE SORTIE DE COURANT, SAUF SI LES LAMES PEUVENT ETRE INSEREES A FOND SANS EN LAISSER AUCUNE PARTIE A DECOUVERT.

TABLE OF CONTENTS

	Page
I. INTRODUCTION	1—2
II. LOCATION AND SETUP	3—14
INSPECTION	3
INSTALLATION	3
SELF-TEST	4
GAME VOLUME ADJUSTMENT CONTROLS	5
OPTION SWITCH SETTINGS	5
GAME OPERATION	5
III. MAINTENANCE AND REPAIR	15—22
CLEANING	15
FUSE REPLACEMENT	15
OPENING THE CONTROL PANEL	15
REMOVAL OF MAIN DISPLAY GLASS AND T.V. BEZEL	16
T.V. MONITOR REPLACEMENT	17
PRINTED CIRCUIT BOARDS REPLACEMENT	19
OPENING THE ATTRACTION PANEL	20
COIN DOOR MAINTENANCE	21
IV. ILLUSTRATED PARTS BREAKDOWN	23—47
PHOTOGRAPH - UPRIGHT	23
REAR ACCESS PICTURE - UPRIGHT	25
PHOTOGRAPH - COCKTAIL	27
INTERIOR ACCESS PICTURE - COCKTAIL	29
PHOTOGRAPH - MINI	32
REAR ACCESS PICTURE - MINI	34
UTILITY SHELF AND SERVICE DOOR - UPRIGHT	36
CONTROL ASSEMBLY	38
COMMERCIAL CARD RACK ASSEMBLY	40
PUSH BUTTON ASSEMBLY	42
FLUORESCENT FIXTURE ASSEMBLY	44
FRONT DOOR ASSEMBLY	46
V. TECHNICAL TROUBLE SHOOTING	48—60
RAM AND PATTERN TEST CARDS	48
PATTERN BOARD TEST	49
PATTERN BOARD THEORY OF OPERATION	51
PATTERN BOARD TEST SCHEMATIC	53
TROUBLE SHOOTING CARD RACK SYSTEM	54
CUSTOM CHIP PIN OUT	56
I/O CHIP DESCRIPTION	57
ADDRESS CHIP DESCRIPTION	57
DATA CHIP DESCRIPTION	58
Z80 CPU PIN DESCRIPTION	59
SERVICE BULLETIN	60

TABLE OF CONTENTS

	Page
VI. MONITOR MANUAL	61—79
WELLS/GARDNER 19" COLOR SCHEMATIC	61
WELLS/GARDNER 19" PARTS LIST	62
ELECTROHOME 19" COLOR SCHEMATIC	64
ELECTROHOME 19" PARTS LIST	65
ELECTROHOME 13" COLOR SCHEMATIC	69
ELECTROHOME 13" PARTS LIST	70
WELLS/GARDNER 13" COLOR SCHEMATIC	74
WELLS/GARDNER SERVICE SECTION	75
ELECTROHOME SERVICE SECTION	77
VII. SCHEMATICS AND WIRING DIAGRAMS	80—98
WIRING DIAGRAM - UPRIGHT	80
WIRING DIAGRAM - MINI	81
WIRING DIAGRAM - COCKTAIL	82
POWER SUPPLY BOARD - COMPONENT LAYOUT	83
POWER SUPPLY BOARD - SCHEMATIC	84
RGB INTERFACE BOARD - COMPONENT LAYOUT	85
RGB INTERFACE BOARD - SCHEMATIC	86
AUDIO AMPLIFIER BOARD - COMPONENT LAYOUT	87
AUDIO AMPLIFIER BOARD - SCHEMATIC	88
RAM BOARD - COMPONENT LAYOUT	89
RAM BOARD - SCHEMATIC	90
CPU BOARD - COMPONENT LAYOUT	91
CPU BOARD - SCHEMATIC	92
PATTERN TRANSFER BOARD - COMPONENT LAYOUT	93
PATTERN TRANSFER BOARD - SCHEMATIC	94
MEMORY BOARD - COMPONENT LAYOUT	95
MEMORY BOARD - SCHEMATIC	96
GAME LOGIC BOARD - COMPONENT LAYOUT	97
GAME LOGIC BOARD - SCHEMATIC	98

I. INTRODUCTION

WIZARD OF WOR INSTRUCTION MANUAL

IMPORTANT NOTE

DO NOT plug your new game in yet. Before you do anything to your game, we recommend that you read Sections I. and II. of this manual completely. It will not take more than a few minutes and it may be very helpful.

I. INTRODUCTION

Welcome to WIZARD OF WOR! In this magical game, you are a warrior descending into deep dungeon mazes, battling invisible monsters, cacodemons, and maybe even the Wizard of Wor himself! Be of good cheer, warrior, for herein lie many of the secrets of the Wizard.

Wizard of Wor is a game for one or two players. When the two player mode is selected, both players control their warriors at the same time. Teamwork in the two player mode is very important (but not necessary to play). If you have a Cocktail Table model, the rules are the same as for the Upright model. Only the player's orientation to the playfield is different.

The game participants, their colors, and their normal point values are:

Name	Color	Point Value
Warrior (player #1)	Yellow	1000 Points
Warrior (player #2)	Blue	1000 Points
Burwor	Blue	100 Points
Garwor	Yellow	200 Points
Thorwor	Red	500 Points
Worluk	Blue + Yellow Wings	1000 Points
Wizard of Wor	Blue	2500 Points

The object of Wizard of Wor is to descend as far into the dungeons of Wor as possible, killing monsters, beating the Wizard, and earning as high a score as you can. The game ends when all the players warriors have been destroyed.

At the start of the game, you are placed in dungeon one. It contains six blue Burwors. Using the joystick and fire button, maneuver your warrior around the maze and shoot them. As you shoot the last Burwor, a yellow Garwor will come out. Garwors and red Thorwors will turn invisible. The radar will show the positions of the invisible monsters. Invisible Garwors and Thorwors will become visible when they enter the same corridor that a warrior is in. As time goes by, the monsters speed up. The longer it takes before you shoot them, the faster they go. When you have destroyed the Thorwor, the first dungeon ends.

In the second dungeon, a different maze is randomly selected. Once again, six Burwors are placed here. More Garwors and Thorwors will appear this time, however. When the last Thorwor has been shot, Worluk will come out and try to escape out one of the side doors. If you shoot him before he escapes, all point values will be doubled in the next dungeon. After Worluk has been shot or has escaped, the Wizard of Wor may then appear. He teleports closer and closer, continuously firing lightning bolts. He continues to do so until either one warrior has been destroyed, or the Wizard has been shot.

After dungeon three or four, a bonus player is awarded (option switch selectable). You must then face the Arena. This is the toughest of the lower level dungeons. The Worlord dungeons begin at dungeon eight. They are very difficult to survive. At dungeon thirteen, another bonus player is awarded, and you must try to win your way through The Pit. The ultimate goal of Wizard of Wor is to survive The Pit without loosing any warriors.

In a single player game, the other warrior (blue) is your friend. He will not shoot you unless you come between him and a monster, then he will try to shoot the monster, and you could be hit by his shot.

In a two player game, both players play at the same time. They do not take turns. The two players may elect to shoot each other. But, if you wish to survive for long, you must use teamwork!

See section two — subsection four — play mode, for a full description of the game. And now warrior, go forth and do battle with the Wizard of Wor!

II. LOCATION AND SETUP

- A. One of the major features of this game is that in the two player mode, the players DO NOT have to take turns at the controls. They EACH have a complete set of fully operational controls.

B. INSPECTION

1. Remove the game from its shipping crate.
2. Inspect the entire outside of it for any signs of damage.
 - a. Any scratches?, dents?, cracks?
 - b. Any broken controls?
 - c. Any broken glass?
 - d. Just look it over closely and make a note of any signs of damage.
3. Remove the shipping cleats from the bottom of the game cabinet. See Figure 1.
 - a. UPRIGHT MODEL ONLY:
 - i. Remove the red shipping brackets shown in Figure 2 which hold down the slide out utility shelf. See label on top of coin box cover.
4. Install the four levelers, one at each corner of the cabinet. See Figure 3.
 - a. Level the cabinet.
5. Open the cabinet and inspect the inside of the game. See Figure 4. Use the following set of guidelines to determine any irregularities.
 - a. All plug-in connectors on wire harness should be firmly seated.
NOTE: ALL connectors and/or plugs are keyed so they will only go together when all pins are properly lined up.
 - b. Replug any connectors found unplugged. DO NOT FORCE PLUGS ONTO CONNECTORS. DO NOT FORCE PLUGS TOGETHER. If it won't go on easily, assuming the keys are lined up, it either does not belong there or is damaged.
 - c. Make sure all printed circuit boards (P.C.B.'s) are firmly seated in their connectors. See Figure 4. These connectors are also keyed. The P.C.B.'s will only go into them one way without being damaged.
 - d. Note the location of the games serial number as shown in Figure 4.
 - e. Check all major subassemblies to be sure they are mounted securely. These sub-assemblies are called out in Figure 5.
 - i. Power supply.
 - ii. Control panel.
 - iii. T.V. monitor.
 - iv. Other P.C.B.'s and/or P.C.B. rack, etc.
6. Make a note of any problems that can't be easily corrected.
7. Call your distributor or service man about your problem list.

C. INSTALLATION

1. Location Requirements:
 - a. Power:
 - i. Domestic — 110 Volts at 60 Hz
 - ii. Foreign — 200 to 240 Volts at 50 Hz
 - b. Temperature — 32°F to 100°F (0°C to 38°C)
 - c. Humidity — Not over 95% relative
 - d. Space required:
 - i. Upright — 24.5" x 23.875" (62.23cm x 60.643cm)
 - ii. Mini — 19.5" x 23.875" (49.53cm x 60.643cm)
 - iii. Cocktail — 32.0" x 22.000" (81.28cm x 55.880cm)
 - e. Game height:
 - i. Upright — 68.25" (173.355cm)
 - ii. Mini — 58.25" (147.955cm)
 - iii. Cocktail — 29.00" (73.660cm)

FIG. 1

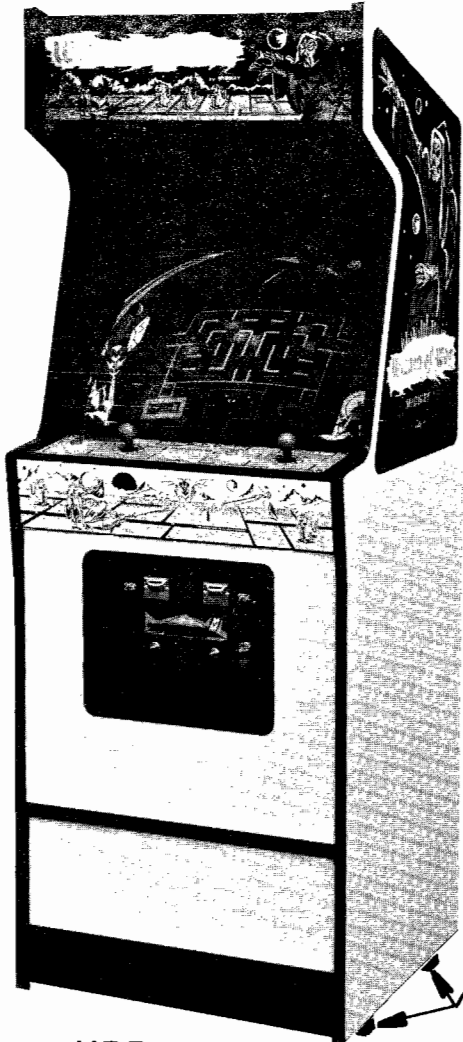

UPRIGHT

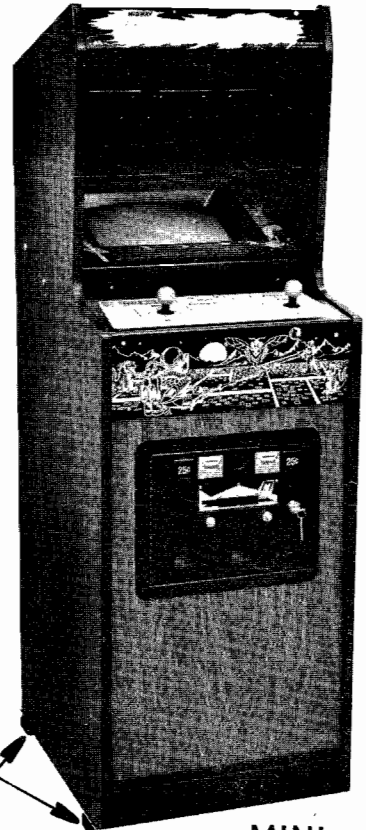

MINI

SHIPPING
CLEATS

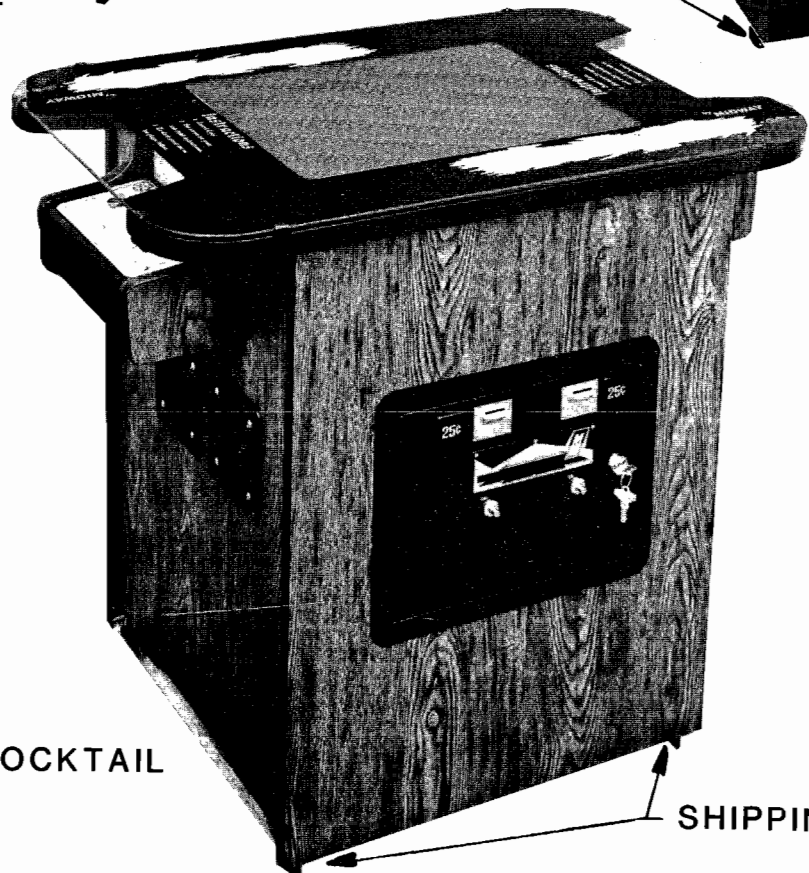

COCKTAIL

SHIPPING
CLEATS

FIG.2
UPRIGHT

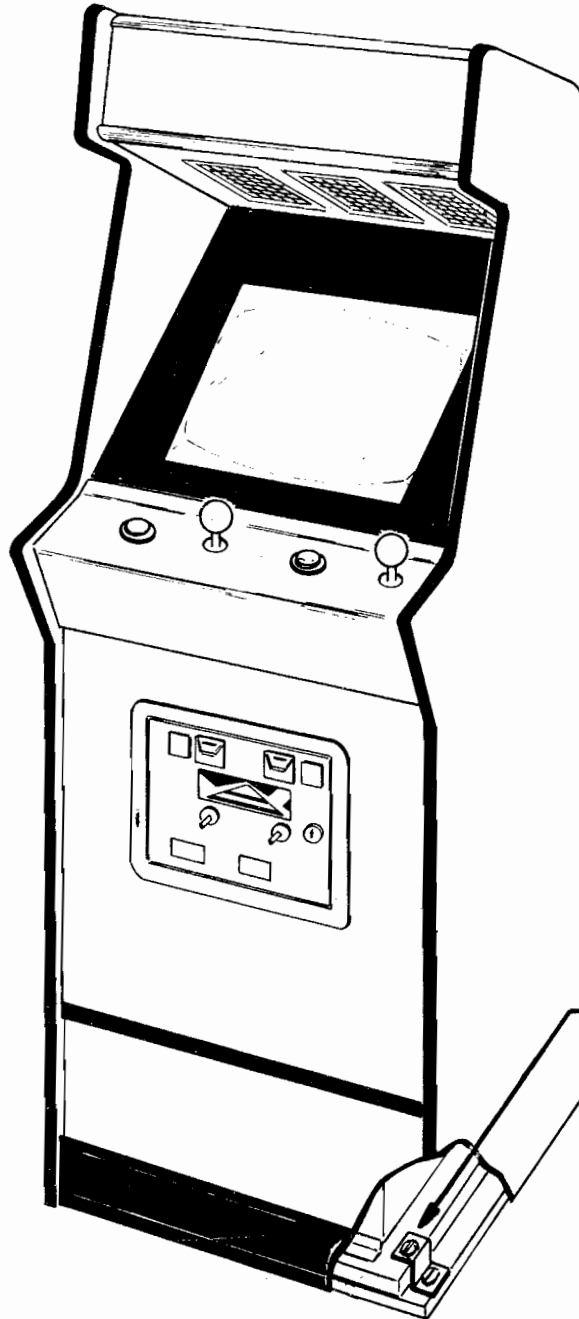

**RED SHIPPING
BRACKETS MUST
BE REMOVED**

FIG.3

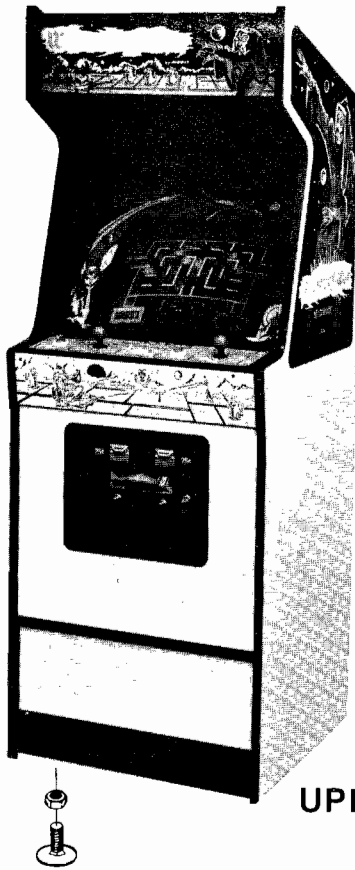

UPRIGHT

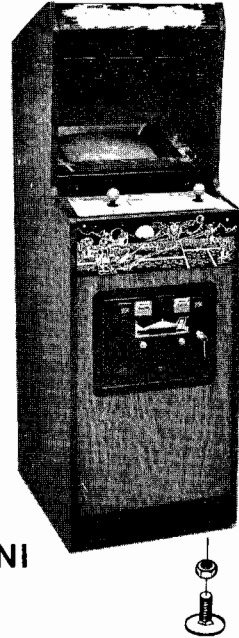

MINI

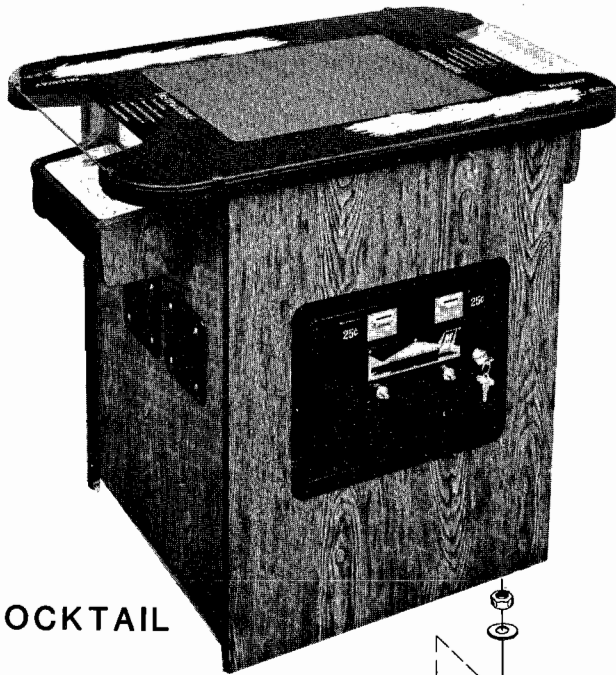

COCKTAIL

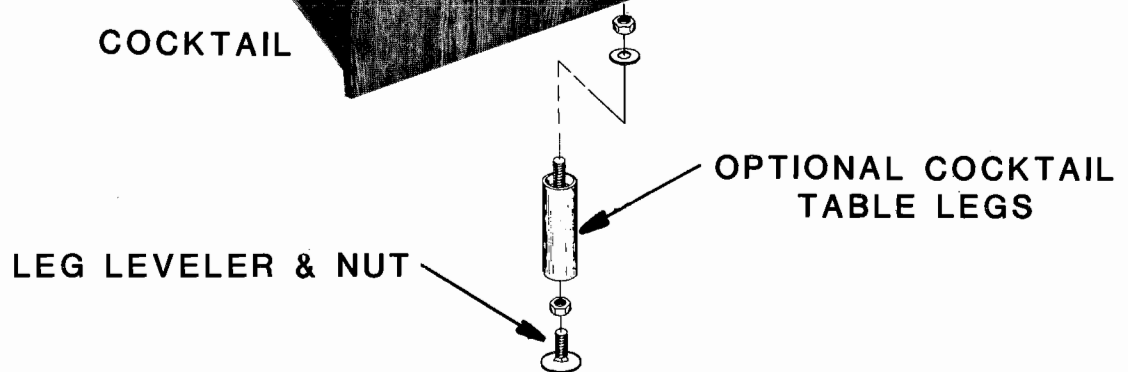
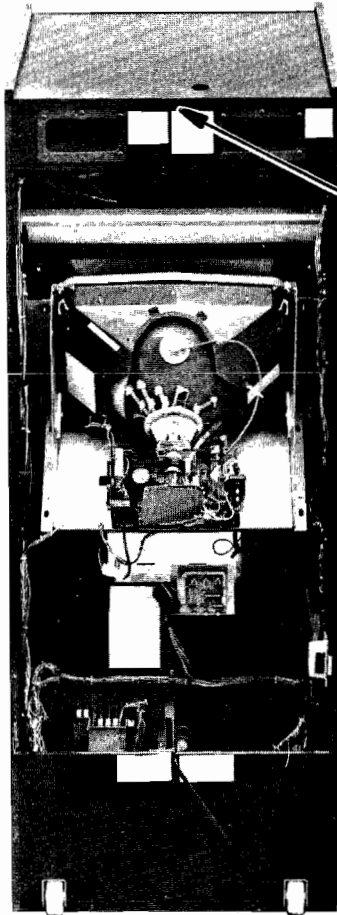
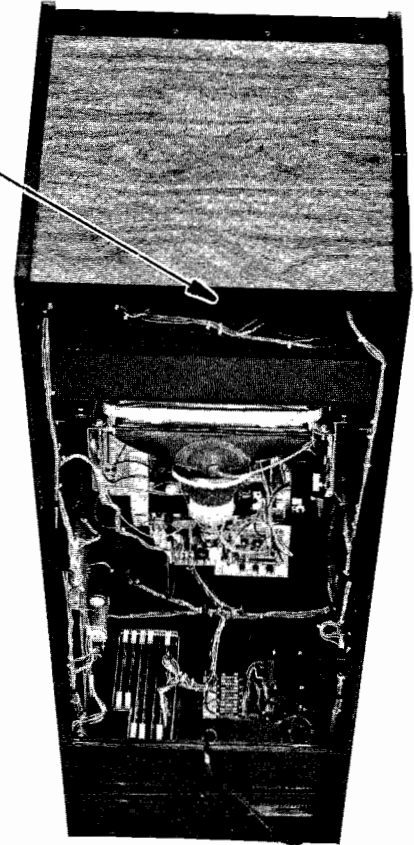

FIG.4



UPRIGHT



MINI

CHECK THAT ALL
PLUG-IN CONNECTORS
ARE SEATED FIRMLY

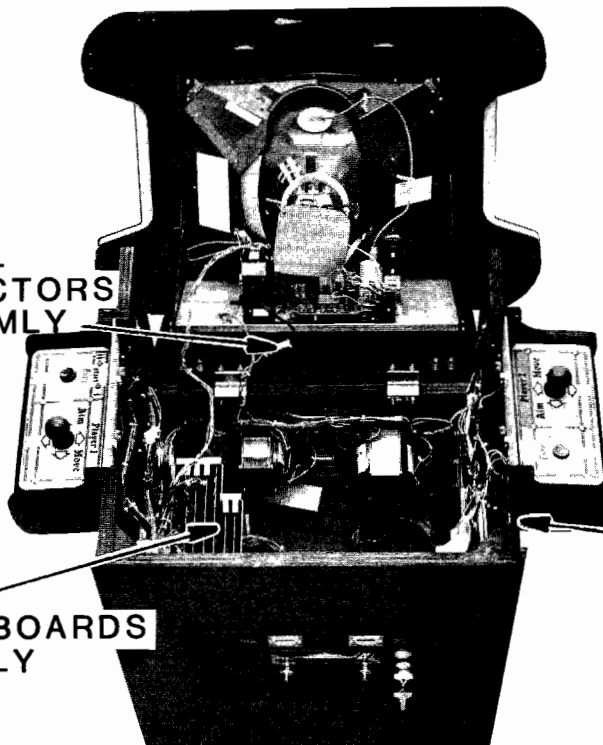

CHECK THAT ALL
PRINTED CIRCUIT BOARDS
ARE SEATED FIRMLY

SERIAL NUMBER

(MAY BE LOCATED
ON ANY CORNER)

COCKTAIL

2. Voltage Selection:

Your game is designed to work properly on the line voltage where you are located. Check your line voltage with a meter to determine what its value is. Then check the power input wires to the main power supply transformer on your game to be sure they are connected to taps which correspond to your line voltage value.

If the power input wires to the main power supply transformer are not connected to taps which correspond to your local line voltage, move them to the proper taps.

If the line voltage in your area falls outside the upper or lower limits of the range of inputs covered by the main power supply transformer, **DO NOT PLUG YOUR GAME IN** until you have talked with your distributor and/or service man and obtained a solution to this problem. Otherwise you could damage your game.

3. Interlock and Power On/Off Switches — See Figure 5.

- a. To help prevent the possibility of getting an electric shock while working inside the game cabinet, interlock switches have been installed at each cabinet access door (this *does not* include the coin door in the Upright and Mini models).
- b. When any access door is opened, the interlock switch installed there turns off all power to the game.
- c. Check each interlock switch for proper operation.
 - i. After checking the line voltage in your area and determining that the input wires to the main power supply transformer of your game are connected properly — or — after obtaining a solution to your over or under voltage problem from your distributor and/or your service man, plug the game into your A.C. wall outlet.
 - ii. The game On/Off switches for all three models are located as shown in figure 5. Turn the game on and let it warm up for a few minutes.
 - iii. Unlock and slowly open each access door to the game (this *does not* include the coin door on the Upright and Mini models).
 - As the door is opened approximately 1", the power to the game should go off (the T.V. monitor, all the lights, and all sounds will stop).
 - If this does not happen, check the interlock switch by this door to see if it has broken loose from its mounting or if it has stuck in the "ON" position.
 - If the switch is found to be bad, turn the game off, unplug it, and replace the interlock switch.
 - Plug the game back into the wall outlet, close the access door and turn the game on.
 - Now, repeat the above interlock switch test.
 - iv. When the interlock switch is working properly and turns the power to the game off, power may be restored to the game with the access doors in the open position by taking hold of the plunger of the interlock switch and *gently* pulling it out. **THIS IS TO BE USED ONLY FOR SERVICING THE GAME!** See Figure 6.

D. SELF-TEST:

Your new game will Self-Test itself to see if it has any bad parts. The information it obtains while testing itself will be shown on the T.V. monitor. Some information can also be heard through the games speaker system.

When there is a bad result according to the Self-Test program, call your distributor and/or service man to have the trouble fixed unless it is something you can do easily yourself (such as replace a ROM or RAM chip, etc.).

FIG.6
INTERLOCK SWITCH

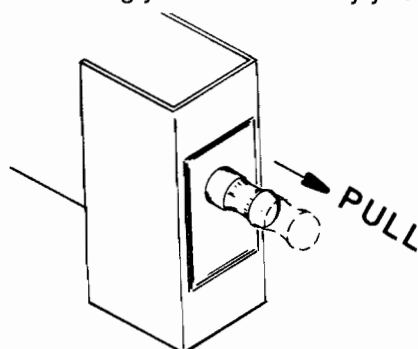

**FIG.5
COCKTAIL**

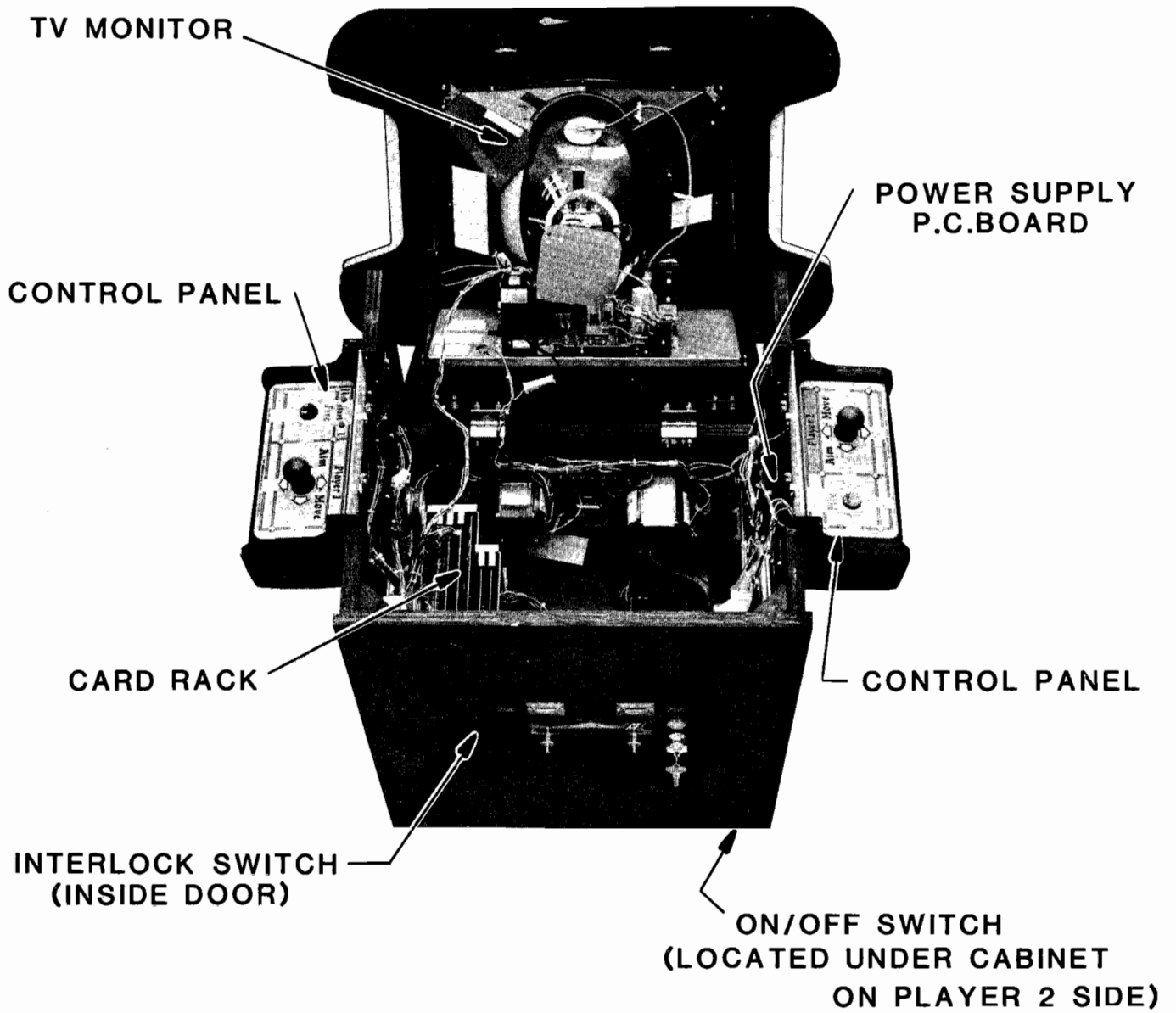

FIG.5
(cont)
MINI

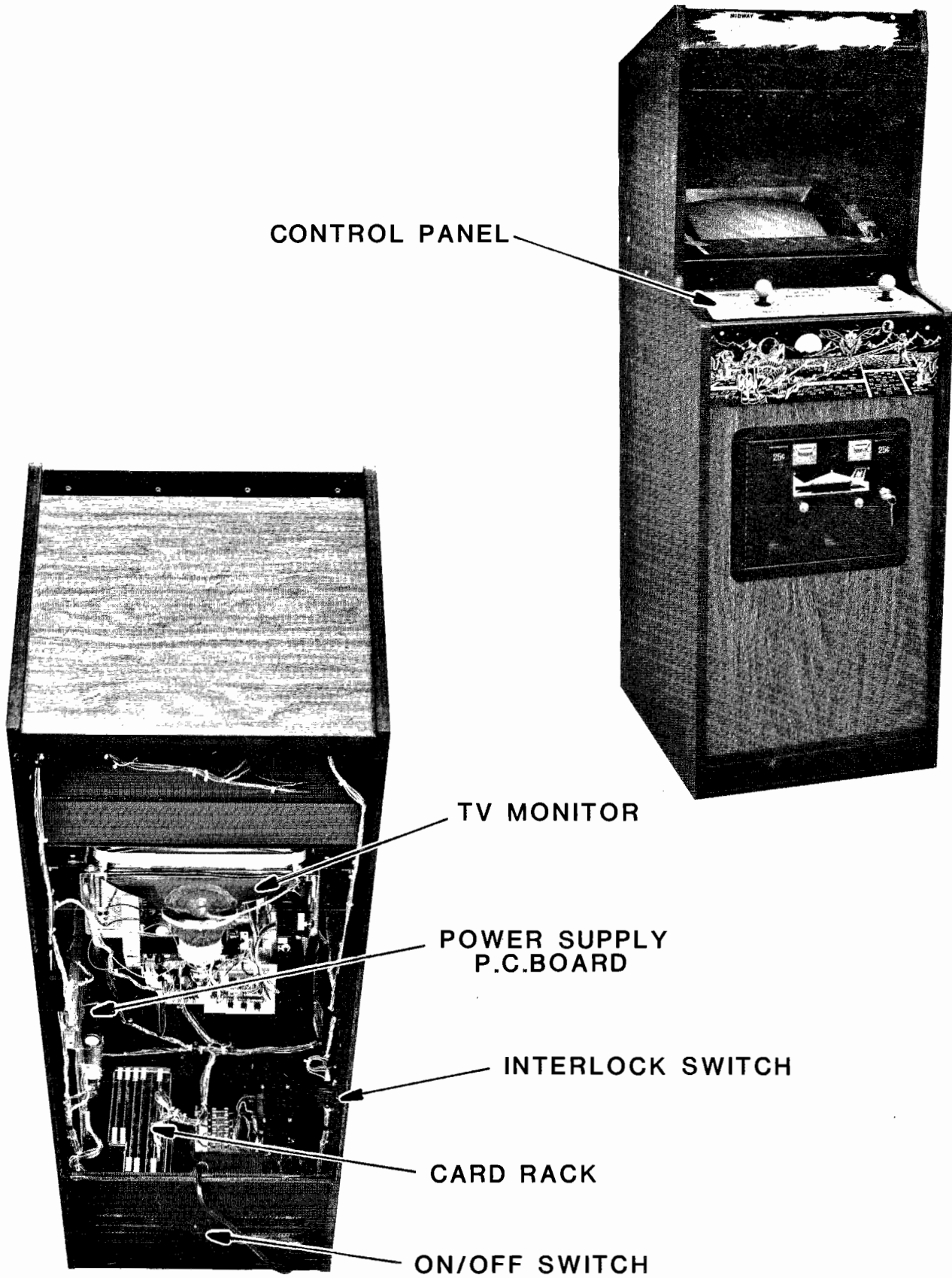
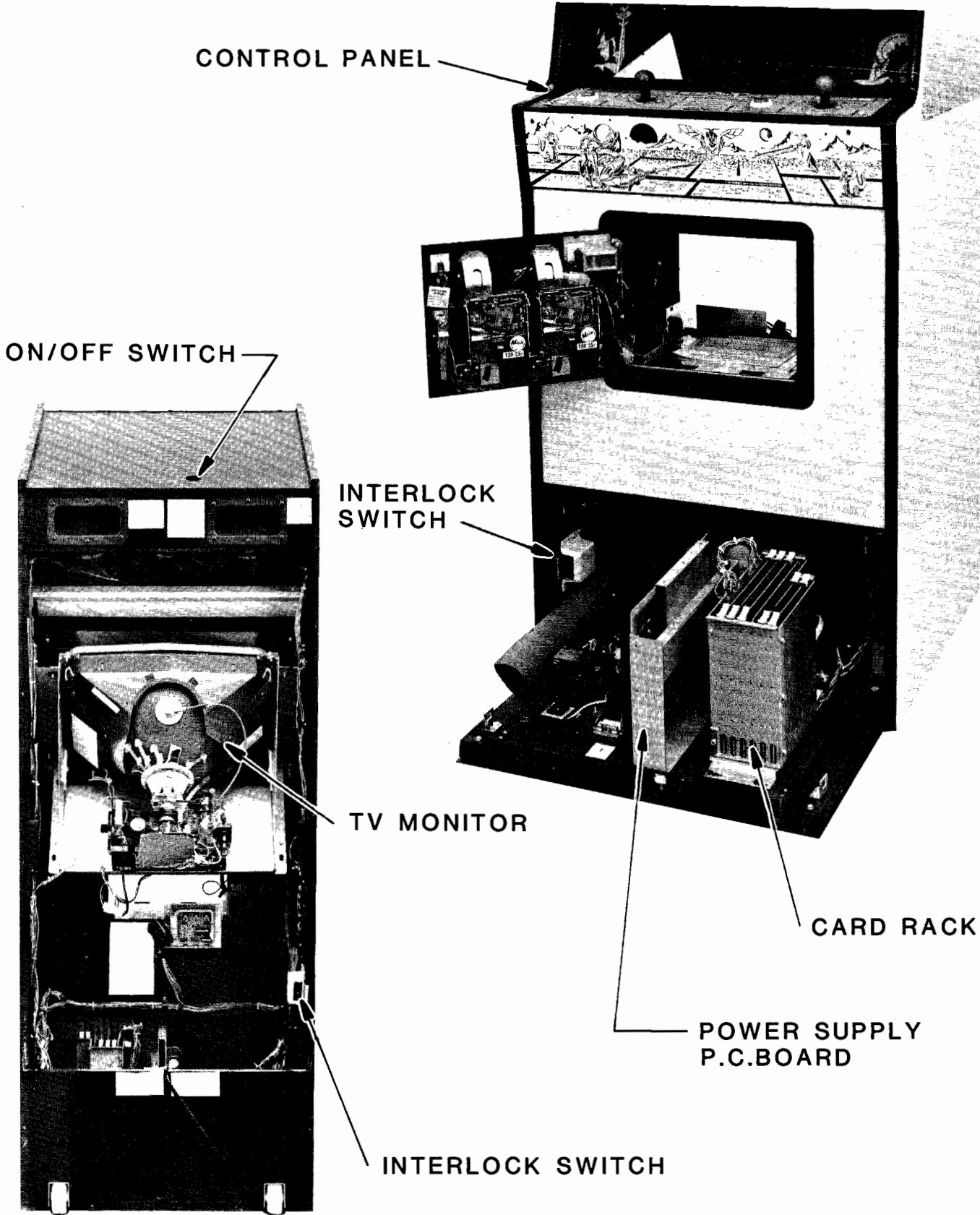



FIG.5
(cont)
UPRIGHT



E. GAME VOLUME ADJUSTMENT CONTROLS — See Figure 7.

The game volume control pots are located on a panel at the back edge of the coin box. There are three pots in all. For adjustment, they may be reached easily through the coin door. As you face them, the left one controls the Wizards voice, the center one controls the left player sounds, and the right one controls the right player sounds.

To make the game sounds louder, turn the pots to the right  as you face them.

To make the sounds less loud, turn the pots to the left  as you face them.

F. OPTION SWITCH SETTINGS — See Figure 8:

To change the settings on the option switches, you DO NOT have to take the game P.C.B. out except on the Cocktail Table models. The switches can be easily reached through the front or rear access door on the Upright and Mini models.

After changing option switches, put the game into the Self-Test mode. This will display the settings of all switches. Double check the switch settings to make sure that all switches are in the correct position. If a switch is set to OFF, then nothing will be displayed beside the switch number. If the switch is set to ON, then a YES will be displayed beside the switch number. Because the switches are so small, be sure that a switch was not accidentally changed.

The option switch settings and what they will make the game do are shown in Figure 9.

G. GAME OPERATION

WIZARD OF WOR is a 1 or 2 player game with a color T.V. monitor. The game gives a display which has all the parts shown in the following illustrations. All of the above are displayed on a background of sparkling stars.

The game has four possible modes of operation: ATTRACT, READY-TO-PLAY, PLAY, and SELF-TEST.

Self-Test is a special mode for checking game switches and computer functions. You may start a Self-Test at any time by sliding the Self-Test switch to the "ON" position. See Figure 10. It is the easiest and best way to check for proper operation of the entire game. When started, the game will react as follows:

NOTE: On all player/operator commands, there is no indication of operation at all until the switch has been activated. Once activated, if working properly, a "YES" will be shown on the monitor screen. This will turn to a "NO" when the switch is allowed to move back to its normal position.

1. Self-Test mode:

The screen will show bright curtains of color which go from the top of the screen to its bottom and back up again (sort of like pulling a window shade down and letting it go); the high scores in the "HIGH SCORE" table are automatically set back to "0"; and a check list is written on the screen from top to bottom.

a. The meaning of each part of this test display is explained below.

i. The letters RAM stand for Random Access Memory.

ii. The letters ROM stand for Read Only Memory.

iii. SCREEN RAM OK

Means the RAM chip that controls the screen functions is working properly. If it were not working properly, the screen will flash alternating colors.

iv. STATIC RAM OK

Means this RAM chip is working properly. If it were not working properly, the word "OK" would be replaced with the word "BAD".

FIG.7
SOUND ADJUSTMENT

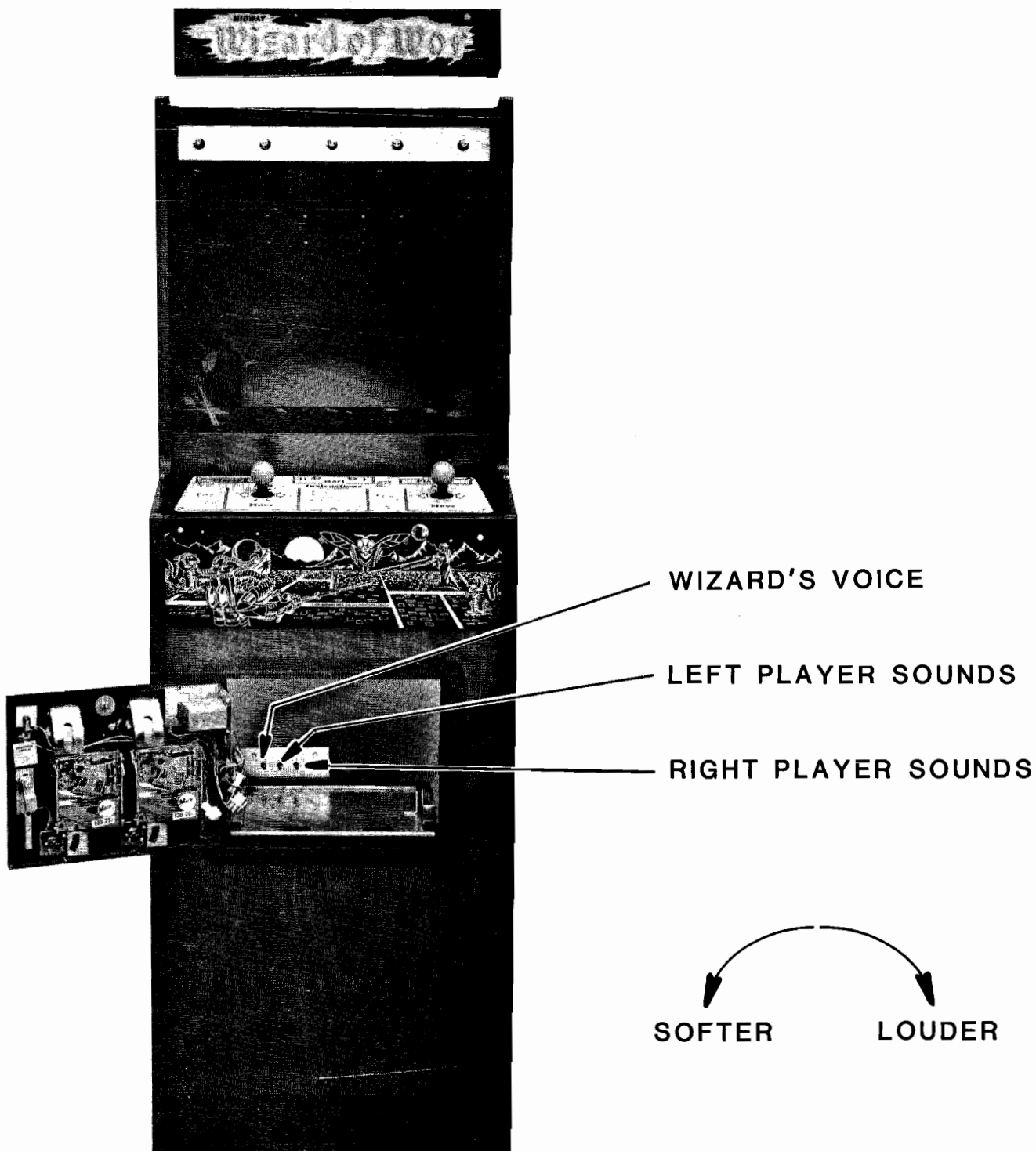
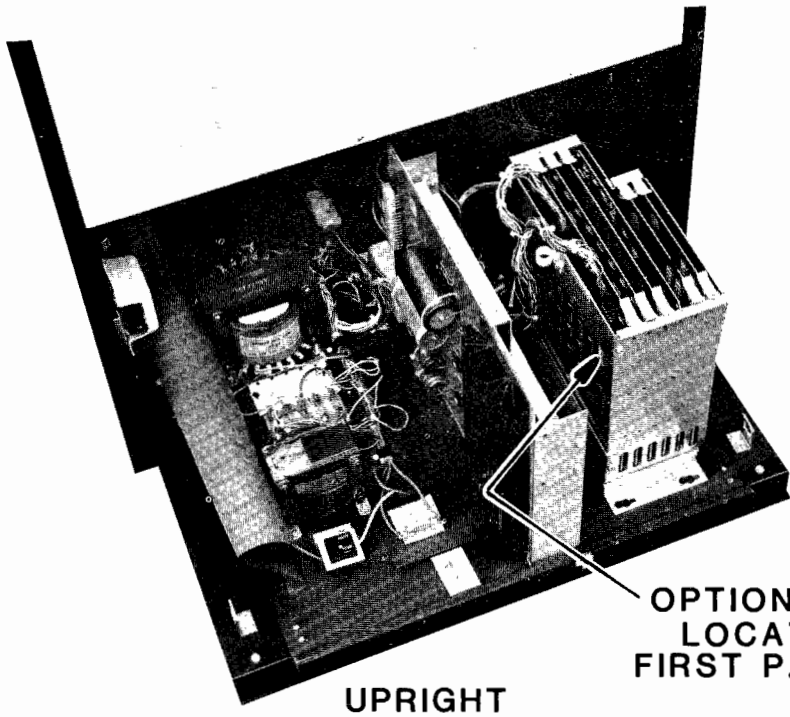
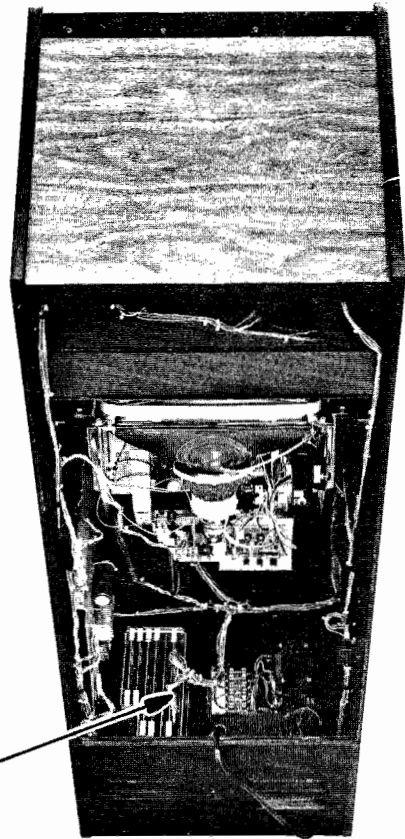

FIG.8



UPRIGHT



MINI

OPTION SWITCH
LOCATED ON
FIRST P.C. BOARD

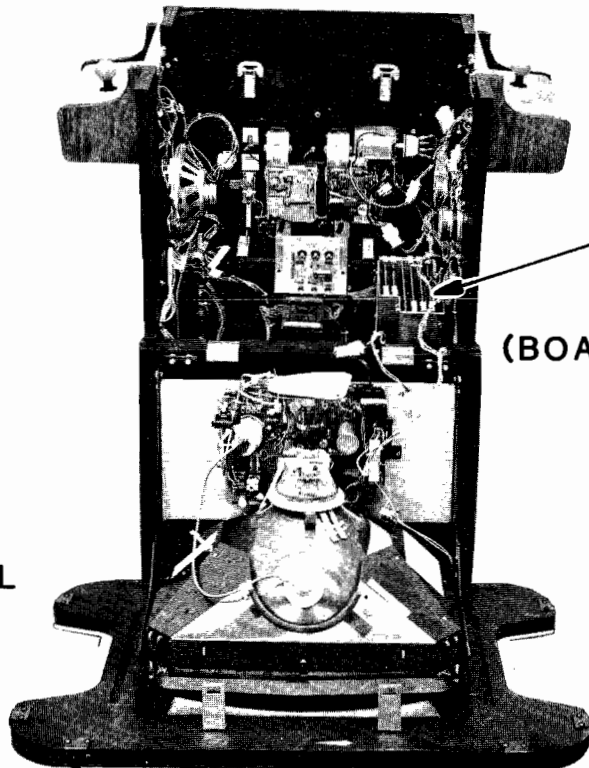
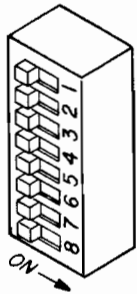

COCKTAIL

OPTION SWITCH
LOCATED ON
FIRST P.C. BOARD
(BOARD MUST BE REMOVED)

FIGURE 9 OPTION SWITCH SETTINGS

WIZARD OF WOR OPTION SWITCH SETTINGS

Option switches are located on the game P.C.B. in the commercial card rack.

COINS PER CREDIT

LEFT HAND COIN SLOT IS CONTROLLED BY SW#1

SW#1			
OFF		1 COIN	1 CREDIT
ON		2 COINS	1 CREDIT

RIGHT HAND COIN SLOT IS CONTROLLED BY SW#2 AND SW#3

SW#2	SW#3		
OFF	OFF	1 COIN	1 CREDIT
ON	OFF	2 COINS	1 CREDIT
OFF	ON	1 COIN	3 CREDITS
ON	ON	1 COIN	5 CREDITS

LANGUAGE

SW#4		
OFF		ENGLISH
ON		FOREIGN LANGUAGE (REQUIRES A082-91374-A000)

WARRIORS PER CREDIT

SW#5	
OFF	1 CREDIT = 2 WARRIORS / 2 CREDITS = 5 WARRIORS
ON	1 CREDIT = 3 WARRIORS / 2 CREDITS = 7 WARRIORS

BONUS PLAYER AWARDED

SW#6	
OFF	BONUS WARRIOR AFTER THIRD DUNGEON
ON	BONUS WARRIOR AFTER FOURTH DUNGEON

PLAY MODE

SW#7	
OFF	COIN PLAY
ON	FREE PLAY

GAME ATTRACTION SOUNDS

SW#8	
OFF	CONTINUOUS SOUND DURING "ATTRACT MODE".
ON	SOUND DURING ATTRACT MODE ONLY IF GAME CONTROLS ARE TOUCHED. (WHEN ANY BUTTON OR CONTROL IS TOUCHED, GAME PROVIDES SOUND FOR ONE COMPLETE CYCLE OF THE "ATTRACT MODE". IT WILL THEN BE QUIET UNTIL TOUCHED AGAIN.)

SPECIAL NOTE

WHEN SETTING THE SWITCHES SW#1, SW#2, AND SW#3 TO EITHER OF THE FOLLOWING TWO COMBINATIONS, ONLY COIN METER NUMBER 1 WILL COUNT.

SW#1	SW#2	SW#3
OFF	OFF	OFF
ON	ON	ON

IF THE ABOVE THREE SWITCHES ARE SET TO ANY OTHER COMBINATION, COIN ACCEPTOR NUMBER 1 WILL CAUSE COIN METER NUMBER 1 TO COUNT AND COIN ACCEPTOR NUMBER 2 WILL CAUSE COIN METER NUMBER 2 TO COUNT.

FIG.10

TEST SWITCH

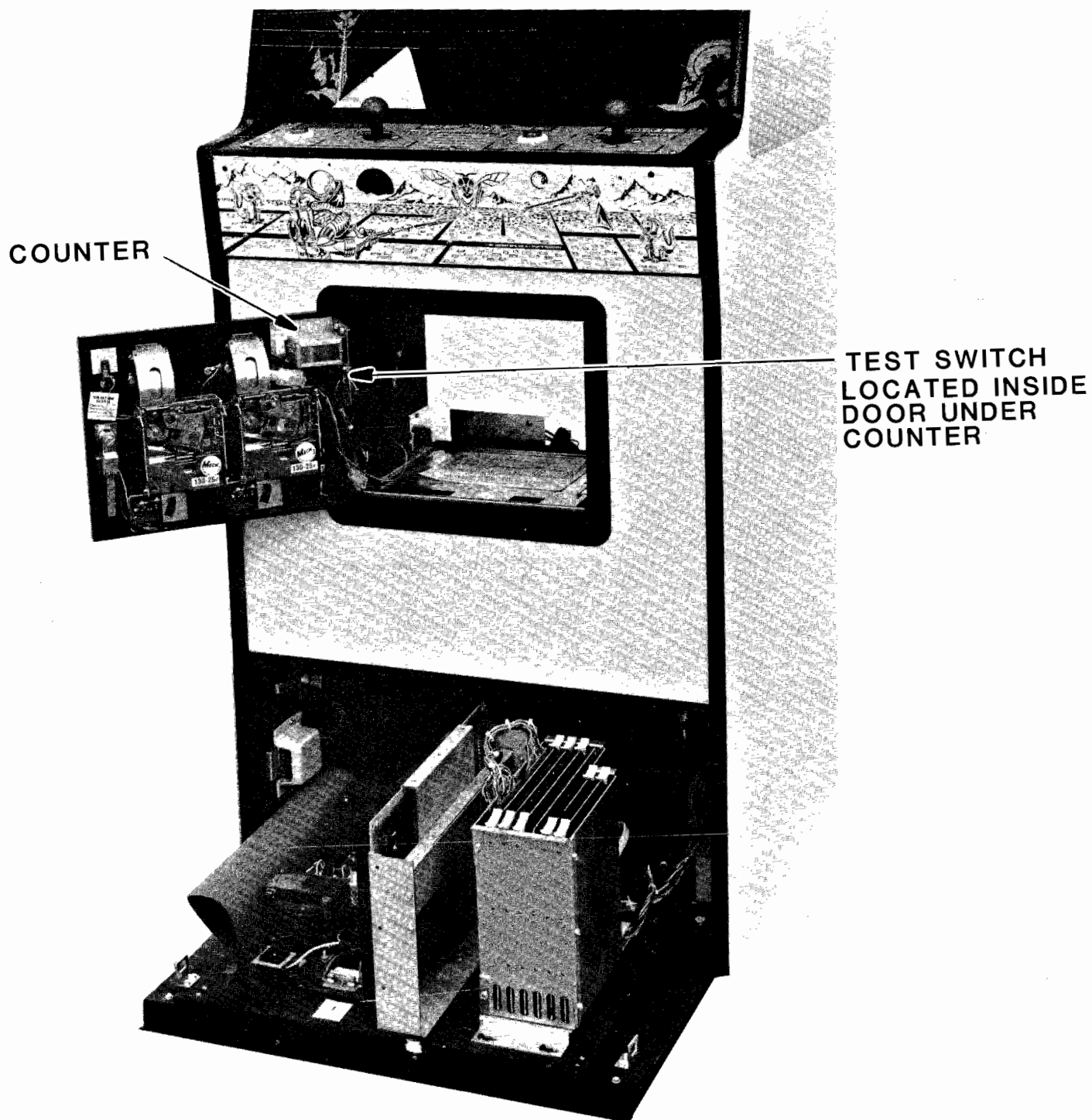

- v. ROM OK
Means that all the ROM's are working properly. There are seven ROM's and *sometimes eight*.
The eight ROM in an "EPROM". These letters stand for Erasable Programmable Read Only Memory.
The ROM's are called out by their identification letter: A, B, C, D, E, F, G, and sometimes X.
"X" is the EPROM. It is selectable via an option switch and is only used in games that have to work with a language *other than* English.
If any of the ROM's are not working properly, their letter(s) will be listed out beside the word "ROM" *instead* of the word "OK".

- vi. MOVE DIR.
This is a two part check of the warrior control stick switches. There are four switches under each control stick; one each for "left", "right", "up", and "down". See Figure 11.
The first part (when switch blades 3 and 1 touch) is the direction command of the warrior — a "DIR" command. This will be displayed as either left-"LF", right-"RT", up-"UP", or down-"DN" according to the position of the control stick.
The second part (when switch blades 3, 1, and 2 all touch) checks the mobility of the warrior — a "MOVE" command. This will be displayed as either a "YES" (that there is movement) — or a "NO" (that there is not).
After both these checks have been performed and the control stick allowed to return to its stationary position, the "MOVE" and "DIR" commands should both register "NO" "NO" to indicate there is not any switch contact.

- vii. PL 1
No indication until the ONE PLAYER START BUTTON is pushed. If this switch is working properly, a "YES" will be displayed next to "PL 1". "NO" will then appear when switch is allowed to return to its normal position.
PL 2, COIN 1, COIN 2, and SLAM all work the same way as described for "PL 1" above.

- viii. COIN 3
No indication at all when there is only a "2 Coin Acceptor" door on the game. When there is a "3 Coin Acceptor" door on the game, it functions in the same way as the other two coin switch tests (COIN 1 and COIN 2).

- ix. SW#1 thru SW#8
These are the Option Selection Switches. A "YES" indication means that particular switch is in the "ON" condition. No indication at all *OR* a "NO" indication means that particular switch is in the "OFF" condition.

NOTE: Whenever one of the *Option Selection Switches* is moved from its OFF position to its ON position to test it, a steady tone will come from the games speaker system. The tone goes away when the switch is moved back to its OFF position.

Whenever one of the *other switches* on the game is moved from its normal position to test it, a steady tone will come from the games speaker system. The tone goes away when the switch is allowed to return to its normal position.

- b. To get a crosshatch grid display on the T.V. monitor:
 - i. Set the Self-Test switch to the "ON" position.
 - ii. Press the 1 PLAYER START BUTTON and the 2 PLAYER START BUTTON at the same time.
 - iii. To turn off the crosshatch grid display, set the Self-Test switch to the "OFF" position.

FIG. 11
SWITCH ADJUSTMENT

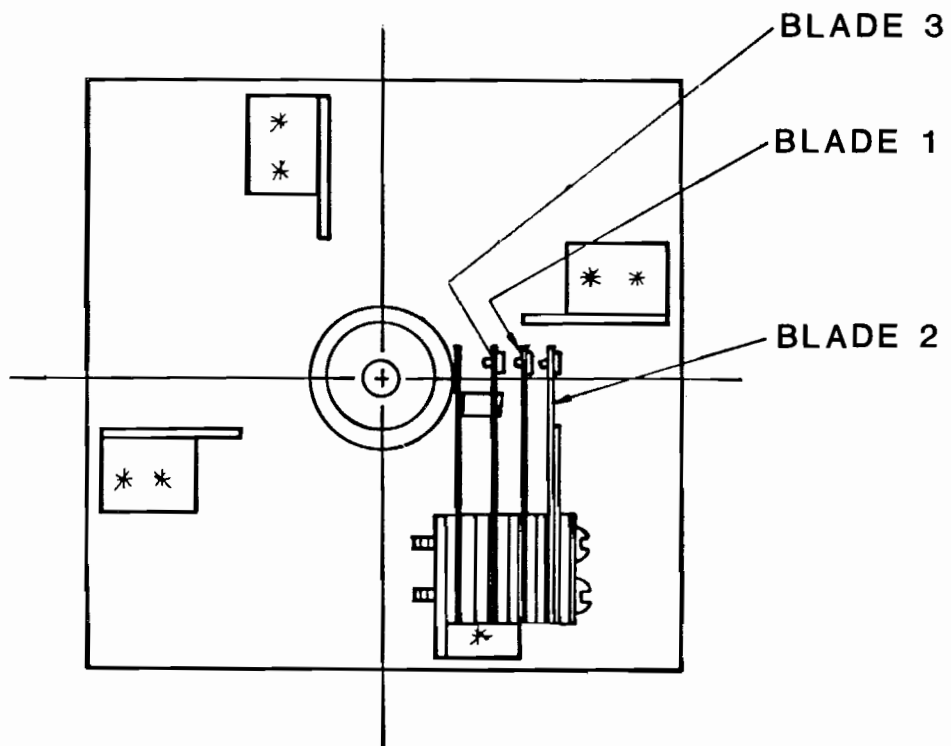

SCREEN RAM OK
 STATIC RAM OK
 ROM OK

MOVE DIR
 NO
 FIRE
 PL 1
 COIN 1
 SLAM

COIN 3

MOVE DIR
 NO
 FIRE
 PL 2
 COIN 2

*At first, nothing is shown in these columns. Once a Switch has been moved (to test it) — "YES" appears in front of that location when switch is working. When allowed to return to its normal position — a "NO" will then be displayed in front of that location.

SW1 SW5
 SW2 SW6
 SW3 SW7
 SW4 SW8

These are your Option Switch settings. Nothing indicated or a "NO" indication means that Switch is in the OFF position and a "YES" means that Switch is in the ON position.

SCREEN RAM OK
 STATIC RAM OK
 ROM OK

MOVE DIR
 NO
 FIRE
 PL 1
 COIN 1
 SLAM

COIN 3

MOVE DIR
 NO
 FIRE
 PL 2
 COIN 2

"YES" is indicated here opposite each of the four other indications if the Control Stick is working correctly.

SW1 SW5
 SW2 SW6
 SW3 SW7
 SW4 SW8

"NO" is indicated here when the Control Stick is in its neutral position. When the Control Stick is moved *left*, "LF" is indicated here. When the Control Stick is moved *right*, "RT" is indicated here. When it is moved *forward*, "UP" is indicated here. And when it is *pulled back*, "DN" is indicated here.

**WIZARD OF WOR COCKTAIL SWITCH
 TEST MODIFICATION**

Screen

Left
 Right
 Down
 Up

Player 1 Control

Up
 Down
 Left
 Right

Screen

Right
 Left
 Up
 Down

Player 2 Control

Up
 Down
 Left
 Right

The Player Select and Fire Buttons are as indicated on the screen.

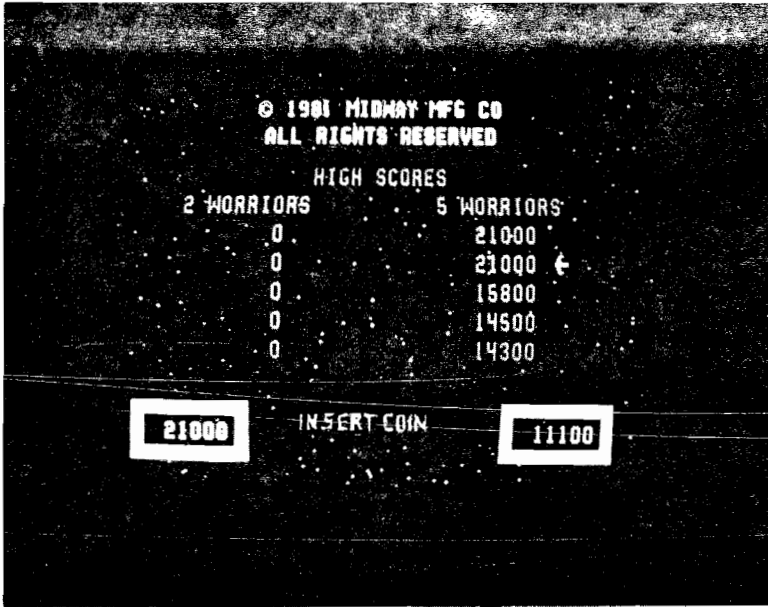

DISPLAY 1

SHOWS SCORES
OF LAST PLAYER(S)
AND LISTS HIGH
SCORES



DISPLAY 2

IS A TABLE OF THE
GAME PLAYERS AND
THEIR POINT VALUES

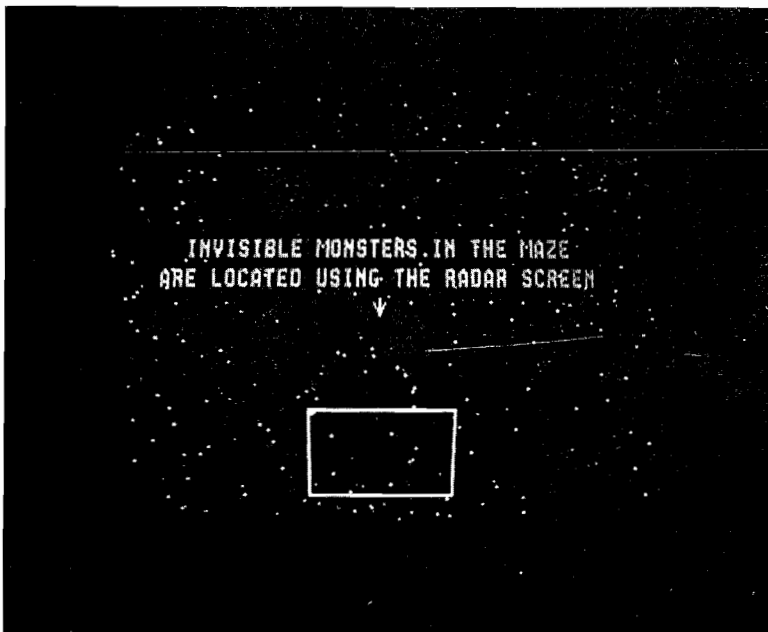

DISPLAY 3

TELLS ABOUT
THE RADAR



DISPLAY 4

IS OF A MAZE WITH
"MONSTORS" AND
"WARRIORS" MOVING
ABOUT IN IT

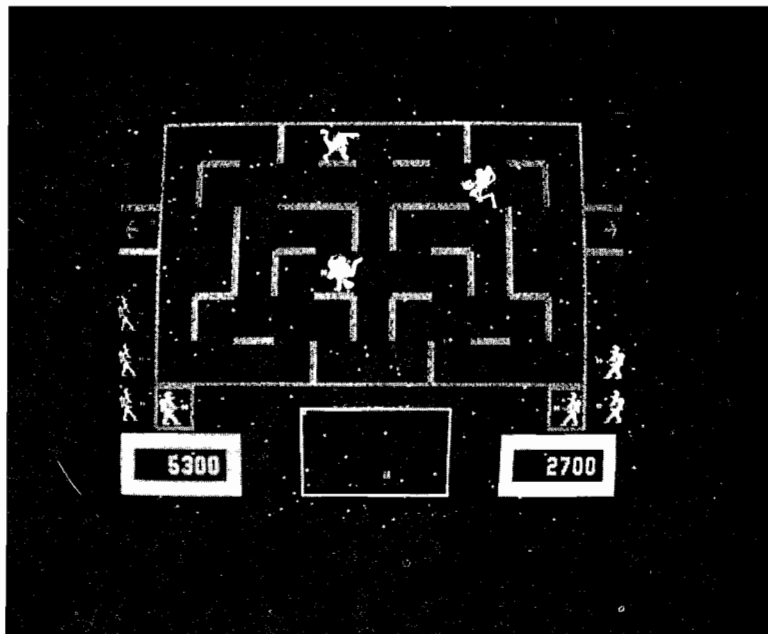

DISPLAY 5

SHOWS A MAZE,
THE RADAR SCREEN,
MONSTORS, AND
WARRIORS. THE RADAR
TRACKS THE MONSTORS
(VISIBLE AND INVISIBLE)
AS THEY MOVE ABOUT
IN THE MAZE

2. Attract mode:

The mode starts:

- a. As soon as power has been turned on to the game.
- b. After a play has finished and there are no more credits left in its memory.
- c. The Attract mode is on all the time and is only stopped when a game has been paid for or when a Self-Test has been started.
- d. In the Attract mode, the game will give the following five displays *centered* on the monitor screen:
NOTE: The number of Warriors per credit is switch selectable.
- e. What is described in "d" above will be repeated until one of the following happens:
 - i. Power to the game is turned off.
 - ii. Coins have been accepted in payment for a game.
 - iii. The Self-Test switch is turned "ON" (to the "TEST" position).

3. Ready-To-Play mode:

- a. The Ready-To-Play mode starts when enough coins have been accepted for a 1 or a 2 player game.
- b. The Ready-To-Play mode ends when the "1 PLAYER START" or the "2 PLAYER START" pushbutton is pressed.
- c. In the Ready-To-Play mode, the game will give the following display *centered* on the monitor screen:

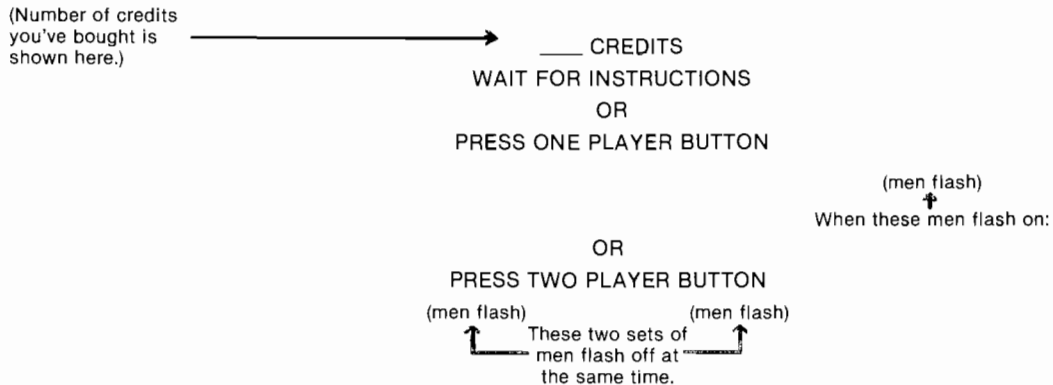

- i. If no PLAYER START button is pressed, the game will go through one cycle of the Attract mode (it leaves out the "HIGH SCORE" table) to show the new player how the game works.
- ii. After this "instruction cycle" is finished, the display on the monitor screen looks like this:

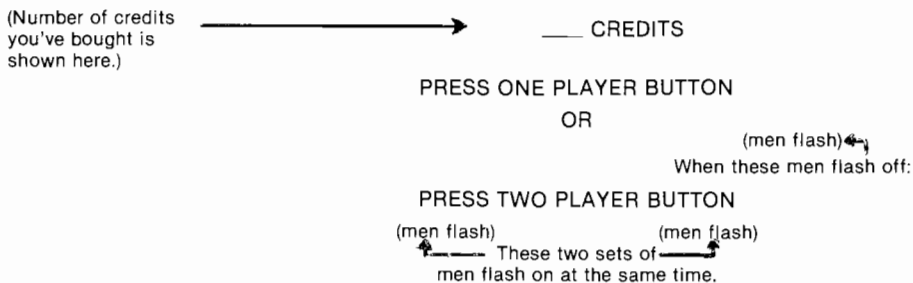

NOTE: The above display is *centered* on the monitor screen.

- iii. The above display will continue until somebody either presses a 1 or a 2 PLAYER START button, a Self-Test is started, or power to the game is turned off.

4. Play mode:
 - a. The Play mode begins after the coins are in and either the 1 or the 2 PLAYER START button has been pressed.
 - b. The Play mode ends when all the warriors have been destroyed in the 2 player mode, or when all the yellow warriors have been destroyed in the 1 player mode. The words "GAME OVER" will appear on the screen and the game will do one of two things:
 - i. If there are credits left on the machine, it will go into the "Ready-To-Play" mode.
 - ii. If there are no credits left, the game will go into the "Attract" mode.
 - c. Game Play and Strategy:
 - i. Overview

The game progresses through a series of dungeon mazes, each one deeper in the caverns of Wor. One other warrior accompanies you into the dungeons, and if you wish to survive for long, you should work with him to conquer the monsters you will encounter. At the start of each dungeon, there are blue Burwors moving around the maze. As you destroy them, yellow Garwors come out, and as you destroy them, red Thorwors take their place. When the last red Thorwor is shot, winged Worluk comes out (not in the first maze). Try to shoot him before he escapes out one of the side doors, as that will double all the point values for the next dungeon. After Worluk has escaped or been shot, the Wizard of Wor might show up. He uses a powerful teleport spell to jump himself from place to place in the dungeon, all the while firing lightning bolts. He keeps reappearing until one warrior has been destroyed, or he himself has been shot. If any warriors are left, the next dungeon is entered. This sequence of events continues until all of the player's warriors have been vanquished.
 - ii. Warriors: Movement, Offence, Strategy

In the basic dungeons, a warrior can learn the fundamentals of survival. It is very easy to walk blind around a corner, into the mouth of a waiting monster. When the monsters are really moving, they are faster than you are. This makes running away difficult. There is a point where you will have to turn and fight them before they eat you.

Your warrior is easy to operate — a four direction joystick for movement in the dungeons, and a fire button for the concentrated unified-field-disturbance rifle. The joystick has two contacts in each direction, a direction contact and a movement contact. A light tap to the joystick will face your warrior in a certain direction, without moving him out of position. To move your warrior, just hold the joystick over in one direction.

The unified-field-disturbance rifle is easy to use. It fires in the direction your warrior is facing. It operates on the principle of a concentrated unified-field-disturbance area coupled with a displacement through four-space. This means that it can create only one disturbance at a time, and the disturbance must continue moving until it expands its energy on some object, usually a monster or a wall of the dungeon.

Only one shot can be in the air at a time. This means that in a short corridor you will be able to fire rapidly, because your shot will always quickly encounter a wall. In a long corridor, the shot stays in the air for a long time, leaving you in hot water if a monster is approaching from the side.

If your shot occasionally seems to go in the wrong direction, it is because your warrior has not fully rounded a corner before firing. Your shot went in the direction you were just facing, not in your new direction. Learning when not to shoot is an important part of the strategy of this game.

Entering the dungeon is simple to do, but at times, particularly in the Worlord dungeons, choosing the right time to enter can be a little tricky. At the start of each dungeon, you have ten seconds to bring your warrior into the maze. To do so, just push the joystick toward the maze. When your warrior comes out, he is facing the radar screen. If you do not bring the warrior out of the ready box immediately, the ten second count-down begins. The numbers of the count are shown next to the ready box. At the end of the ten seconds, your warrior will automatically be brought into the dungeon. At the beginning of a dungeon, all the

monsters are started away from the two ready boxes. But since the monsters move randomly at first, they can start to move closer to you. Also, when a warrior has been destroyed, you may immediately bring a new warrior into play. However, monsters might be milling about next to your ready box. To avoid being eaten, wait for the monsters to clear the area before bringing your warrior out.

It is important to note that a new warrior can be brought in at any point during play. If you get eaten or shot, just bring in another warrior and have at it! This is particularly useful with Worluk, who may eat you once, but not escape immediately. It is often possible to bring a second warrior in, and kill Worluk for double score on the next dungeon, before he escapes.

In a one player game, the blue warrior is controlled by the computer. He is a first in video gaming, as he is your friend inside the machine. He will never shoot at you, he shoots only at monsters. Sometimes, he will even save your life by shooting a monster sneaking up behind you. Be careful not to get between him and a monster, for he will still try to shoot the monster, and you might catch his shot.

Teamwork is also a major point of strategy in Wizard of Wor. In the basic dungeons, there are places where two warriors can cut off the monsters as they try to enter the corridor where the warriors are standing. This position is strong but not invincible. The monsters, particularly the last few monsters left in a maze, are moving fast enough to occasionally duck in between shots, and eat you. Back to back in a short corridor is good teamwork. Note that the two warriors can pass through each other unhindered. But be careful! When you are close together, it's very easy to accidentally shoot each other.

In the early mazes, it is to your advantage to initially go out and shoot as many monsters as you can. This is because the monsters move slowly at first, but get faster later. The more slow monsters you shoot, the fewer fast monsters will be left to eat you. When the monsters speed up, then find a good teamwork spot.

In the upper level mazes, the Worlord dungeons, the critical thing is to not miss a shot, for if a shot misses a monster, it is likely to travel a long way before hitting a wall, and in that time a monster will probably come along and eat you. In some of the Worlord dungeons, there are places that two warriors can defend effectively, but they are very hard to get to, and often one player might lose a warrior trying to move into position. When you reach The Pit, you're on your own...

iii. Dungeons:

There are two levels of overall difficulty in the dungeons — basic dungeons and Worlord dungeons. In addition, there are two special dungeons, the Arena and The Pit, which occur at special times during play.

Each dungeon consists of an eleven-by-six matrix of squares, with a wall or opening on the sides of each square. The maze is symmetrical around the center vertical axis. Every maze has a side escape door located four squares up from the bottom, and on each side of the maze. Going out the door on one side brings you in the door on the other side. This can be confusing at first, but becomes quite handy when you get used to it. After using the side escape door, it remains closed for a short amount of time before reopening. When Worluk is out, the door always remains open. Proper use of the side escape door will sometimes aid in escaping trouble, and can also help to cut off Worluk before he escapes.

The basic dungeons consist of many short passages with many possible different pathways, and some long corridors. At first glance, the long corridors appear to be the most strategic spot, but this is not true. Due to the firing mechanism, it is usually the most dangerous spot, as you are not able to fire very often. Finding good places for team work is relatively easy here.

In the area between the radar screen and the dungeon, a description of some current important aspect of the game is displayed. In dungeon one, the word "RADAR" is shown, indicating to the novice player the function of the radar. On other dungeons, the level of the current dungeon is indicated. When Worluk comes out, the word "WORLUK" is displayed there, as is "WIZARD OF WOR" when he shows up.

It tells when either of these has "ESCAPED". And it tells when "DOUBLE SCORE" has been earned for shooting Worluk. It also tells you of "THE ARENA" and "THE PIT".

Below the bottom of the dungeon is the radar. This shows you the location of every monster in the dungeon, visible and invisible. It is important to learn to use the radar to anticipate a monster coming from behind. The only creatures that do not show on the radar, are the warriors and the Wizard himself.

When you have reached dungeons eight and above, you have become a Worlord. Now you have the honor of testing your skill in the Worlord dungeons. These dungeons are much tougher, there are fewer walls and more open spaces. If even one shot misses, and travels the long distance down to the opposite wall, a monster will very likely come up and gobble you down. Finding and establishing yourself in solid strategic positions is very difficult. It is easy to have several warriors chomped up in a row. Sometimes the monsters will line up along one edge of the maze — a lovely parade. However, if just one monster starts approaching from the top, watch out!

The Arena is the dungeon that comes when the first bonus player is awarded. Since the bonus player is switch selectable for the fourth or the fifth maze, the same switch will also control the appearance of the Arena. It is the most difficult maze of the basic dungeons, featuring an arena. This is a large open area in the middle of the dungeon, with openings level with the side escape doors. This is a preview of the Worlord dungeons and The Pit.

Surviving The Pit is the ultimate goal of Wizard of Wor. The Pit occurs at the thirteenth dungeon, and every sixth dungeon thereafter. In other words, the 19th, 25th, 31st, etc. dungeons are The Pits. One missed shot here is almost certain to be fatal. The Wizard is particularly deadly here, as there is nowhere to hide. A bonus player is awarded at the first Pit. The other Pits do not award a bonus player. Sophisticated maneuvering, intestinal fortitude (guts), and a bit of luck are needed to make it through The Pit unscathed. Surviving The Pit without loosing a warrior earns you the title of Worlord Supreme. Best of luck!

iv. Monsters Burwor, Garwor, and Thorwor:

The Wizard of Wor loves to hear the patter of little feet running through his dungeons. So he created some lovely beasties, known as Worlings.

Burwor is beautiful, bouncing blue. Six of them exist on each dungeon level. They always remain visible. This is because the Wizards favorite color is blue. As each Burwor is shot, a Garwor may come to take his place. Garwor is kind of overfed, and waddles a bit, but he has yellow scales that are just delicate. As Garwors are shot, Thorwors are teleported in to take their place. Thorwor is sleek and dangerous red.

All of these monsters can shoot an occasional lightning bolt. Only Garwor and Thorwor have the Wizards spell of invisibility. They become visible when they enter the same corridor as a warrior, and when they are initially teleported in.

In the first dungeon, when the last Burwor is shot, he is replaced by a Garwor. When a monster is placed in the dungeon, it is at a random location, somewhere away from both warriors. In the second maze, the last two Burwors are replaced by Garwors. The progression continues until the sixth dungeon, when all six Burwors are replaced by Garwors. Whenever a Garwor is shot, he is replaced by a Thorwor. So, in the first dungeon, there are a total of eight monsters: six Burwors, one Garwor, and one Thorwor. In the second maze there are a total of ten monsters: six Burwors, two Garwors, and two Thorwors. In the sixth dungeon, there are a total of eighteen monsters: six Burwors, six Garwors, and six Thorwors. This is the maximum number of monsters in one dungeon level.

Note that there are really no more than six monsters in one dungeon at any one time. It just seems like there are more.

All of the monsters work on a speed-up timer. This timer increments the speed of the monsters every time it counts down, which is about every seven seconds. A Garwor that replaces a Burwor will start at the speed the Burwor was going when destroyed. The same is true for Thorwors. So, in the early mazes, Garwors and

Thorwors end up going faster than Burwors, although, given enough time, Burwors can get moving as fast as any monster. In dungeon four and before, any monster traveling at top speed will always be visible. In later dungeons, Garwors and Thorwors will still become visible at top speed. In dungeon seven, the Burwors start at top speed. Any monster traveling at this speed is not able to shoot lightning bolts.

v. Worluk... the Wizard's favorite:

In the second dungeon and beyond, Worluk will come out after the last Thorwor has been shot. Worluk is a lightning quick Cacodemon. He's the Wizards favorite. He flies erratically through the maze, trying to reach one of the side escape doors. The Wizard tried to train him to fly to the door on the opposite side of the maze that he is initially teleported to. However, Worluk's chaotic nature leads him to frantically fly about, sometimes flying out the side escape door closest to him. If you shoot Worluk, all the scores in the next dungeon are doubled. This means that killing Worluk is essential for high scores. A good strategy is to position your warrior by the door that Worluk should use to escape. If Worluk should eat your warrior, bring the next one immediately into play, and go after him again! Remember, he is worth double score on the next maze. But, at the moment that Worluk has been shot, beware warrior! For it is then that the Wizard of Wor might choose to appear.

vi. The Wizard of Wor:

Even at a young age, the Wizard showed promise in the mystic arts. But it took many dangerous encounters and many years of research and study to sharpen his skills to his current high level. Over the centuries, the Wizard has retained his chaotic sense of humor, much to the chagrin of warriors entering his dungeons (see the list of phrases).

The Wizard will sometimes come out after Worluk has been shot. He uses multiple teleport spells to pop around the dungeon, eventually homing in on one warrior or the other. All the while, he wildly fires lightning bolts in every direction. At first he teleports some distance away from one warrior. Then, on successive teleports, gets closer and closer. Note that if the two warriors are very near each other, the Wizard may teleport right next to one of them the very first time. This is because he was teleporting a certain distance away from the other warrior, and happened to come up right next to the first warrior.

The Wizard will continue to teleport and fire lightning bolts until either one warrior has been destroyed or the Wizard has been shot. Shooting the Wizard does not kill him, it only banishes him until the next dungeon.

In almost every dungeon there is a possibility that the Wizard could show up. This possibility is based on the level of the dungeon you are currently in, and on the total number of warriors left in the game. However, even at the highest dungeon level, it is not certain that he will appear.

Standing in a long corridor when the Wizard is teleporting in can be quite risky. If he comes up in that corridor, he will have a clear shot at you.

As you get deeper into the dungeons, the Wizard stays for a shorter period of time, and teleports even faster. This means he gets closer a lot faster, so you must try and shoot him soon after he first comes out. Otherwise, he may end up teleporting right next to you! The Wizard loves to fool warriors by teleporting behind them. But watch out, he will also surprise you by popping up right in front of you.

The Wizard says, "Scores of 150,000 or more are exceptional". Now, you're off to see the Wizard, the magical Wizard of Wor.

vii. The Wizard speaks:

This is a list of the phrases the Wizard says throughout the game:

- Insert coin and game over mode:
 - 1) Hey! Insert Coin!
 - 2) Find me... The Wizard of Wor.
 - 3) I'm out of spite, ha ha ha ha!

- Get ready or coin acceptance mode:
 - 1) Get ready, warrior.
 - 2) You better hope you don't find me, the Wizard of Wor.
 - 3) Another coin for my treasure chest.
 - 4) Ah good! My pets were getting hungry. Ha ha ha ha!
 - 5) My worlings are very very hungry. Ha ha ha ha!
 - 6) Welcome to my world of Wor.
 - 7) So you've come to score in the world of Wor. Ha ha ha ha!
 - 8) You're off to see the Wizard, the magical Wizard of Wor.
- Dungeon start-ups:
 - 1) Kill Worluk for double score.
 - 2) You are in the dungeons of Wor.
 - 3) I am the Wizard of Wor.
 - 4) One bite from my pretties, and you'll explode, ha ha ha ha!
 - 5) Worluk will escape through the door.
 - 6) Watch the radar, warrior.
 - 7) Thorwor is red, mean, and hungry for space food.
 - 8) Remember, I'm the wizard, not you.
 - 9) If you can't beat the rest, then you'll never get the best! Ha ha ha ha!
 - 10) You'll never leave Wor alive! Ha ha ha ha!
 - 11) If you destroy my babies, I'll pop you in the oven! Ha ha ha ha!
 - 12) Burwor hasn't eaten anyone in months. Ha ha ha ha!
 - 13) My babies breath fire warrior.
 - 14) I'll fry you with my lightning bolts.
 - 15) Burwor, Garwor, and Thorwor will do you in.
 - 16) My creatures are radioactive.
- Bonus player awarded:
 - 1) You'll get... The Arena! Ha ha ha ha!
 - 2) Another warrior for my babies to devour.
 - 3) Keep going and you will find me.
 - 4) A few more dungeons and you will be a Worlord.
 - 5) Warrior fear, I draw near, each time I appear. Ha ha ha ha!
 - 6) You won't have a chance for your dance warrior. Ha ha ha ha!
 - 7) Now you're asking for trouble warrior.
 - 8) Now I'm getting mad warrior.
- First Garwor appears:
 - 1) Now you get the heavyweights! Ha ha ha ha!
 - 2) Garwor, go after them!
 - 3) If you try any harder, you'll only meet with doom, ha ha ha ha!
 - 4) If you get too powerful, I'll take care of you myself, ha ha ha ha!
 - 5) My magic is stronger than your weapons, warrior.
 - 6) Warrior, while you developed science, we developed magic.
 - 7) Your bones will lie in the dungeons of Wor, ha ha ha ha!
 - 8) Garwor and Thorwor, become, invisible! Ha ha ha ha!
- Wizard kills warrior:
 - 1) You've just been fried by the Wizard of Wor! Ha ha ha ha!
 - 2) Bite the bolt warrior. Ha ha ha ha!
 - 3) Wasn't that lightning bolt delicious? Ha ha ha ha!
 - 4) And my teleporting spell can be even faster! Ha ha ha ha!
 - 5) Now you know the taste of my magic, warrior.
 - 6) Maybe you'll see me again warrior.
 - 7) Your explosion was music to my ears! Ha ha ha ha!
 - 8) I'll say it again, warrior fear, I draw near, each time I appear. Ha ha ha ha!

- Worlord dungeon startups:
 - 1) Worlord, be forwarned! You approach, The Pit!
 - 2) Your path leads directly to The Pit! Ha ha ha ha!
 - 3) Deeper, ever deeper into the dungeons of Wor.
 - 4) Beware! You are in the Worlord dungeons!
 - 5) Ah! You thought you could hide but I'm the dungeon master.
 - 6) Thor Bur Gar! Dinners ready! Ha ha ha ha!
 - 7) Hey! Your space boot's untied! Ha ha ha ha!
 - 8) My beasts run wild in the Worlord dungeons. Ha ha ha ha!
- Phrases for The Pit:
 - 1) Now your only chance is your dance! Ha ha ha ha!
 - 2) Are you fit, to survive The Pit? Ha ha ha ha!
 - 3) Oops! I must have forgotten the walls! Ha ha ha ha!
 - 4) Worlord, where are you going to hide now? Ha ha ha ha!
- End of game:
 - 1) Come back for more with the Wizard of Wor. Ha ha ha ha!
 - 2) The dungeons of Wor await your return, worrior.
 - 3) Deep in the caverns of Wor, you will meet me, worrior.
 - 4) The Wizard of Wor thanks you.
 - 5) You know you can do better worrior.
 - 6) Hurry back! I can't wait to do it again.
 - 7) You can start anew, but for now you're through. Ha ha ha ha!
 - 8) He he he ho ho ho ha ha ha! That was fun!

When you have reached the Worlord dungeons, the Wizard calls you Worlord, instead of worrior.

III. MAINTENANCE AND REPAIR

III. MAINTENANCE AND REPAIR

Your WIZARD OF WOR game needs certain types of maintenance to keep it in good working order. Clean, well maintained games attract players and earn more profits.

The most important thing for you to remember is to run the Self-Test every time you collect money from the coin box. Just looking at your game will not tell you if all its controls and inside parts are working correctly. The Self-Test will inform you whether or not your game is working the way it should.

The second most important thing you should remember is to clean the outside of the game and coin acceptor mechanism on a regular basis.

A. CLEANING

The outside of the cabinet plus the metal can be cleaned with any non-abrasive household cleaner. However, the front of the monitor T.V. tube and *both sides* of all glass and plastic **MUST** be cleaned with anti-static cleaner **ONLY**. For cleaning the coin acceptors: hot soapy water may be used on the plastic ones and any household cleanser may be used on the metal ones. If you wish, special coin machine cleaners that leave no residue may be purchased from your distributor.

DO NOT dry-wipe any of the plastic panels. This is because any dust that was on them can scratch their surfaces. If this has happened, anyone looking through this type of damaged plastic would feel he was looking at the game through a fog. This fogging damage **CAN NOT** be repaired or reversed. The **ONLY** solution is to *replace* the damaged piece of plastic.

B. FUSE REPLACEMENT

This game contains 6 fuses located as follows: (See Figure 12.)

1. Upright model:

As viewed from the front, facing the game, with the utility shelf slid out through the games front access door; five fuses are located between the main power transformer and the T.V. isolation transformer. The sixth fuse is located just to the right of the service outlet.

2. Mini model:

As viewed from the back, facing the cabinet, with the back access door removed; 6 fuses are located just in front of the T.V. isolation transformer and to the right of the main power transformer.

3. Cocktail Table model:

As viewed from the coin door side of the cabinet, with the monitor tilted open to one side, the 6 fuses are located between the T.V. isolation transformer and the main power transformer up against the side of the cabinet.

Replace fuses **ONLY** with the type and size listed in the *Illustrated Parts Breakdown Section* of this manual.

See the T.V. monitor manual for information about its fuses.

C. OPENING THE CONTROL PANEL — SEE FIGURE 13:

1. Upright model:

- a. The control panel is held in place by two latches, one on the left side and one on the right side of the cabinet.
 - i. They are spring loaded to provide constant positive pressure on their latch plates.
 - ii. They can be reached through the coin door **AFTER** turning power to the game off.
 - iii. To release the latches, lift up and toward the center of the control panel.
 - Once they are released, unhook them from their latch plates.

FIG. 12

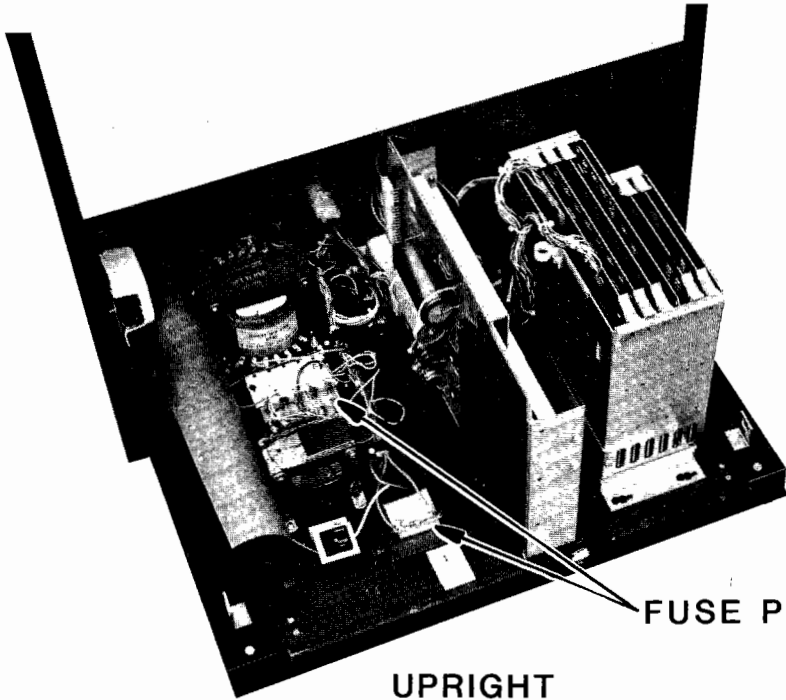

UPRIGHT

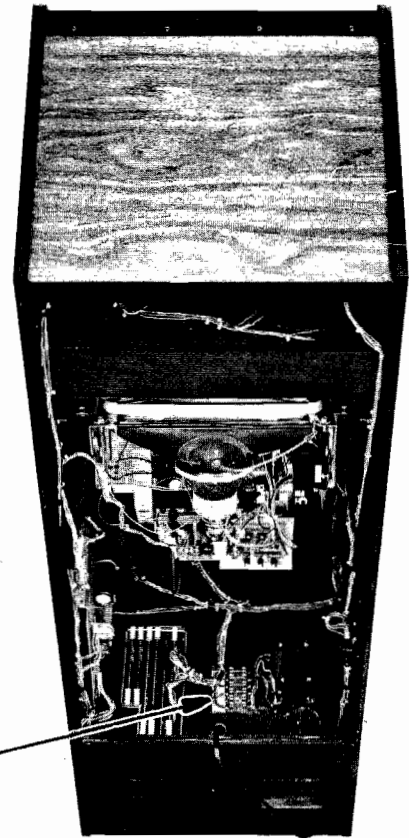

MINI

FUSE PANEL

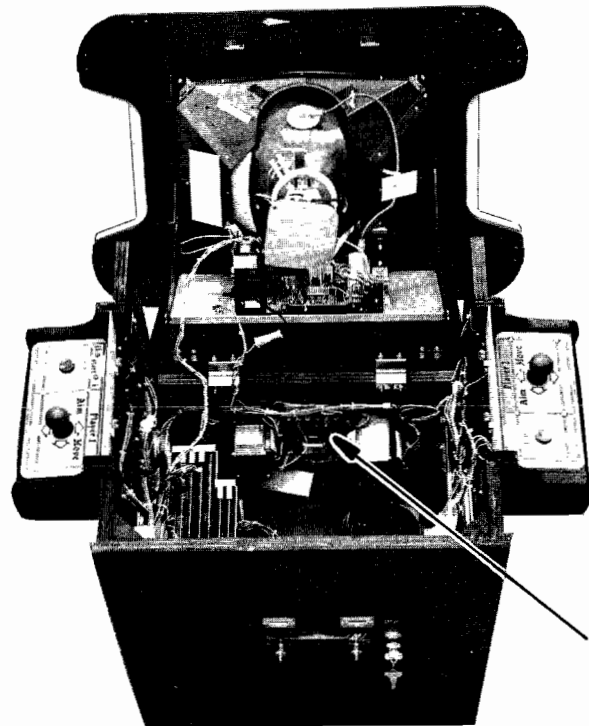

FUSE PANEL

COCKTAIL

FIG.13
COCKTAIL

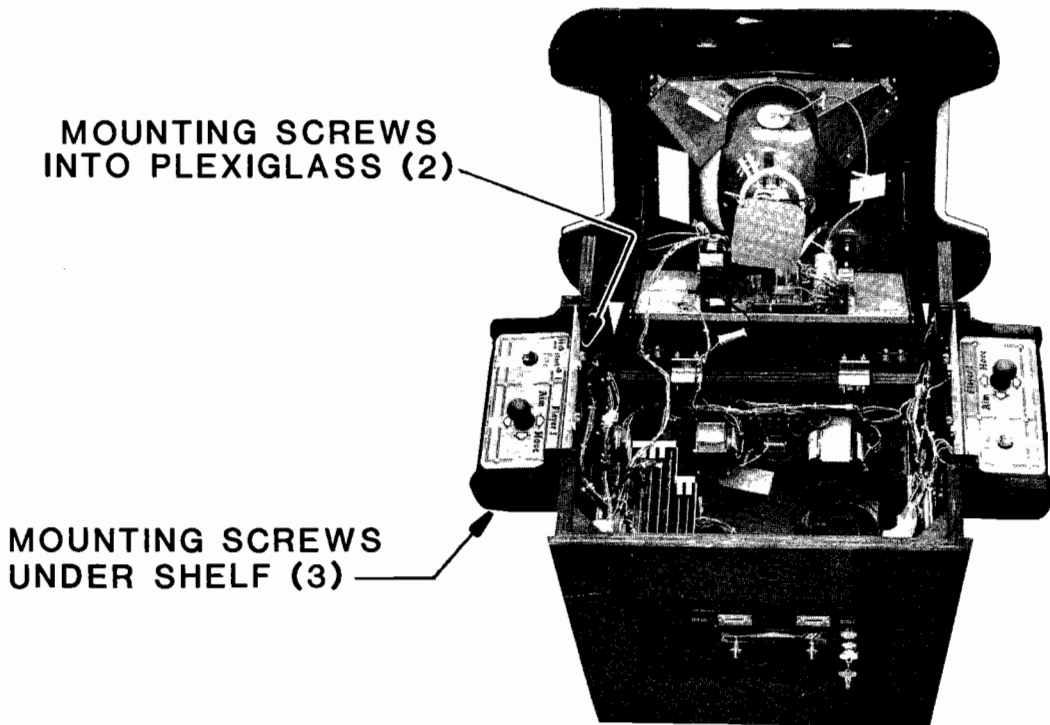
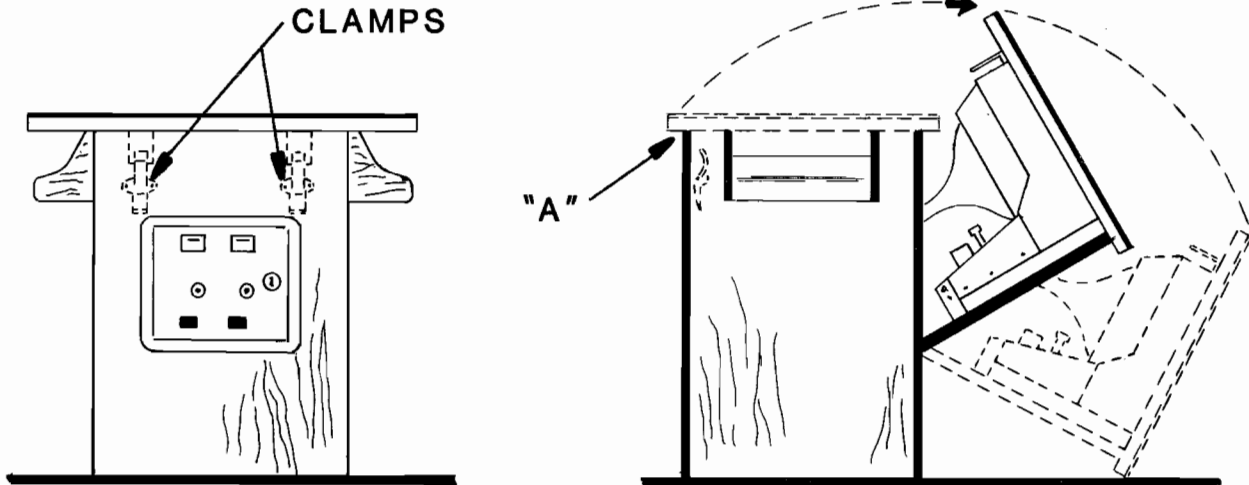
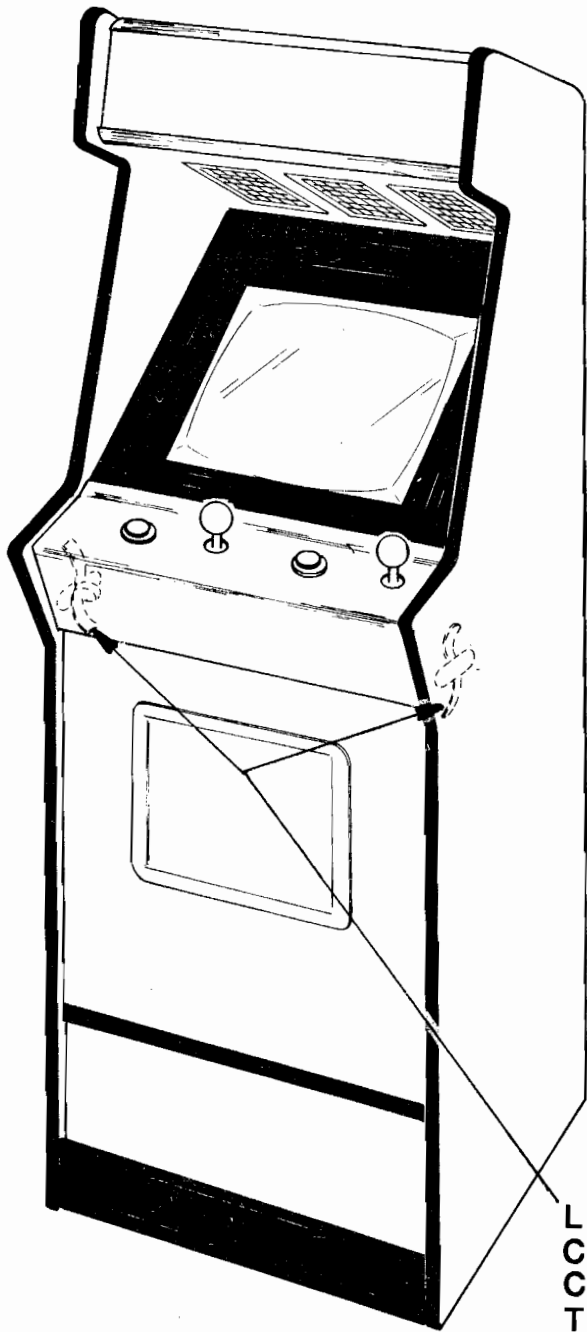
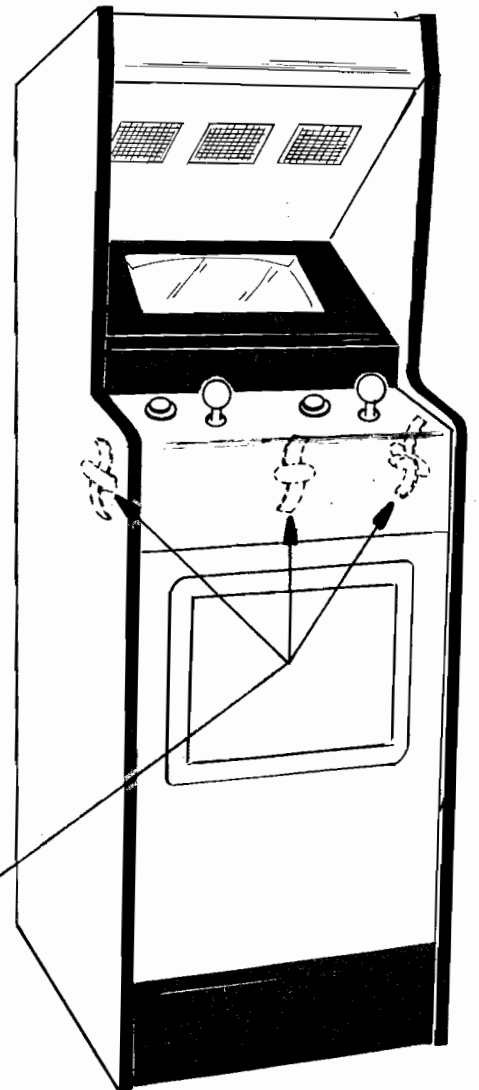

FIG. 13



UPRIGHT

**LATCHES FOR
CONTROL PANEL
CAN BE REACHED
THRU COIN DOOR**



MINI

- b. To remove the control panel:
 - i. Raise it up and tilt it toward you until you can see the cable behind it.
 - ii. Cradling the control panel between yourself and the cabinet, disconnect it from its cabling.
 - iii. The control panel is now free and can be removed.
- c. To reinstall the control panel, reverse this procedure.

2. Mini model:

- a. The control panel is held in place by three latches, one on the right side, one on the left side, and one on the front center.
 - i. They are spring loaded to provide constant positive pressure on their latch plates.
 - ii. They can be reached through the coin door AFTER turning power off to the game.
 - iii. To release the latches, lift up and toward the center of the control panel.
 - Once they are released, unhook them from their latch plates.
- b. To remove the control panel:
 - i. Raise it up and tilt it toward you until you can see the cable behind it.
 - ii. Cradling the control panel between yourself and the cabinet, disconnect it from its cabling.
 - iii. The control panel is now free and can be removed.
- c. To reinstall the control panel, reverse this procedure.

3. Cocktail Table model:

- a. Each control panel is held in place by several screws, two on the inside of the cabinet and three along the bottom edge of the control panel.
 - i. Turn the power to the game off.
 - ii. Open the coin box door and release the two latches indicated in Figure 13.

CAUTION: The right hand latch is close to HIGH VOLTAGE on the monitor.

 - Once they're released, unhook them from their latch plates.
 - iii. Grasp the table top at "A" and open it as indicated in Figure 13.

CAUTION: Due to the weight of the monitor, EXTREME CARE MUST be taken when opening the cabinet.
 - iv. Remove the screws which secure the control panel in place. See Figure 13.
- b. To remove the control panel(s):
 - i. Disconnect it from its cabling.
 - ii. The control panel is now free and can be removed.
- c. To reinstall the control panel(s), reverse this procedure.

D. REMOVAL OF THE MAIN-DISPLAY-GLASS AND T.V. BEZEL ASSEMBLY:

1. Upright model:

NOTE: In order to do this on this model, the control panel MUST be removed first. See above "Upright model" procedure.

- a. Turn the power off to the game and remove the control panel. This frees the main-display-glass so it can be lifted up.
- b. On the left or right side of the cabinet, as you face it, reach under the main-display-glass support. Push up on the back side of the glass by reaching through a slot in the T.V. bezel which was put there for this purpose. This frees the main-display-glass so it can be lifted out. See Figure 14.
- c. Remove the screws which secure the T.V. bezel in place and lift it out. See Figure 15.
- d. To reinstall the T.V. bezel and main-display-glass, reverse this procedure.

2. Mini model:

NOTE: In order to do this on this model, the control panel MUST be removed first. See above "Mini model" procedure.

- a. Turn the power off to the game and remove the control panel.
- b. Remove the screws which secure the glass clamping plate. See Figure 16.

- c. Lift out the glass clamping plate. This frees the main-display-glass so it can be lifted up.
- d. By putting your finger in the hole in the center of the main-display-glass support, you can lift it up and out. See Figure 16.
- e. Remove the screws which secure the T.V. bezel assembly, see Figure 17, and lift it out.
- f. Reverse this procedure to reinstall the T.V. bezel assembly and the main-display-glass.

3. Cocktail Table model:

NOTE: This may be done with the table top in the closed or the open position. If you decide to open the table top, TURN POWER TO THE GAME OFF FIRST.

- a. Remove the screws which secure the table top clamps in Place.
- b. Remove the table top glass.
- c. Lift out the T.V. bezel assembly.
- d. To reinstall the T.V. bezel assembly, reverse this procedure.

E. T.V. MONITOR REPLACEMENT — SEE FIGURE 18:

NOTE: We suggest you use two persons to remove the T.V. monitor from the game cabinet. One person can do it, but two persons make it a lot easier and safer.

CAUTION: *High voltages may exist* in any television unit, *even with power disconnected*. Use extreme caution and do not touch electrical parts or the T.V. yoke area with your hands or with metal objects in your hands!

In addition, be sure to use heavy gloves when handling the monitor. You could cut your hands on the metal T.V. chassis, without such protection.

DANGER!: The T.V. monitor does not contain an isolation transformer on its chassis (it is mounted on the floor of the cabinet instead). When servicing the monitor on a test bench, YOU MUST ISOLATE IT FROM AC VOLTAGE WITH AN ISOLATION TRANSFORMER.

1. Upright model:

- a. Turn the power off to the game.
- b. Completely disconnect the T.V. monitor from all its cabling. DON'T FORGET THE CHASSIS GROUND WIRE.
- c. Before removing the T.V. monitor, the main-display-glass and bezel assembly must be removed first. See above "Upright model" procedure.
- d. With the removal of only four bolts, the T.V. monitor will be loose.
- e. The monitor mounting bracket slides on top of and against two "L" brackets mounted to the cabinets right and left sides. The monitor is removed by lifting up and backward at the same time. See Figure 18.
- f. To reinstall the T.V. monitor, reverse this procedure.
- g. After replacing a T.V. monitor, be sure to run the game Self-Test.

2. Mini model:

- a. Turn the power off to the game.
- b. Completely disconnect the T.V. monitor from all its cabling. DON'T FORGET THE CHASSIS GROUND WIRE.
- c. Before removing the T.V. monitor, the main-display-glass and bezel assembly must be removed. See above "Mini model" procedure.
- d. With the removal of only four bolts, the T.V. monitor will be loose.
- e. The monitor mounting bracket slides on top of and against two "L" brackets mounted to the cabinets right and left sides. The monitor is removed by lifting up and backward at the same time. See Figure 18.
- f. To reinstall the T.V. monitor, reverse this procedure.
- g. After replacing a T.V. monitor, be sure to run the game Self-Test.

FIG.14
UPRIGHT

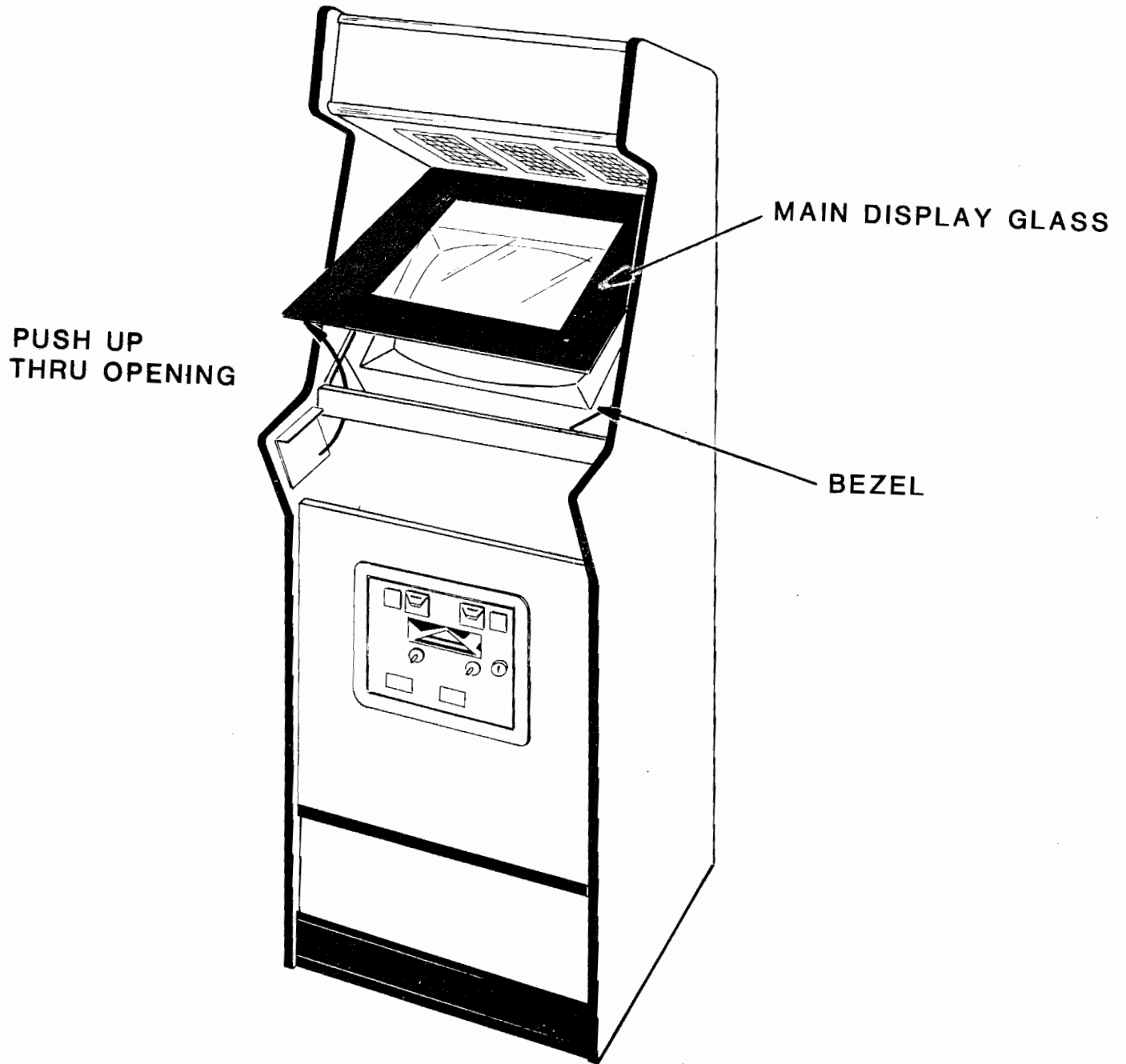

FIG.15
UPRIGHT

**REMOVE SCREWS
AND LIFT OFF**

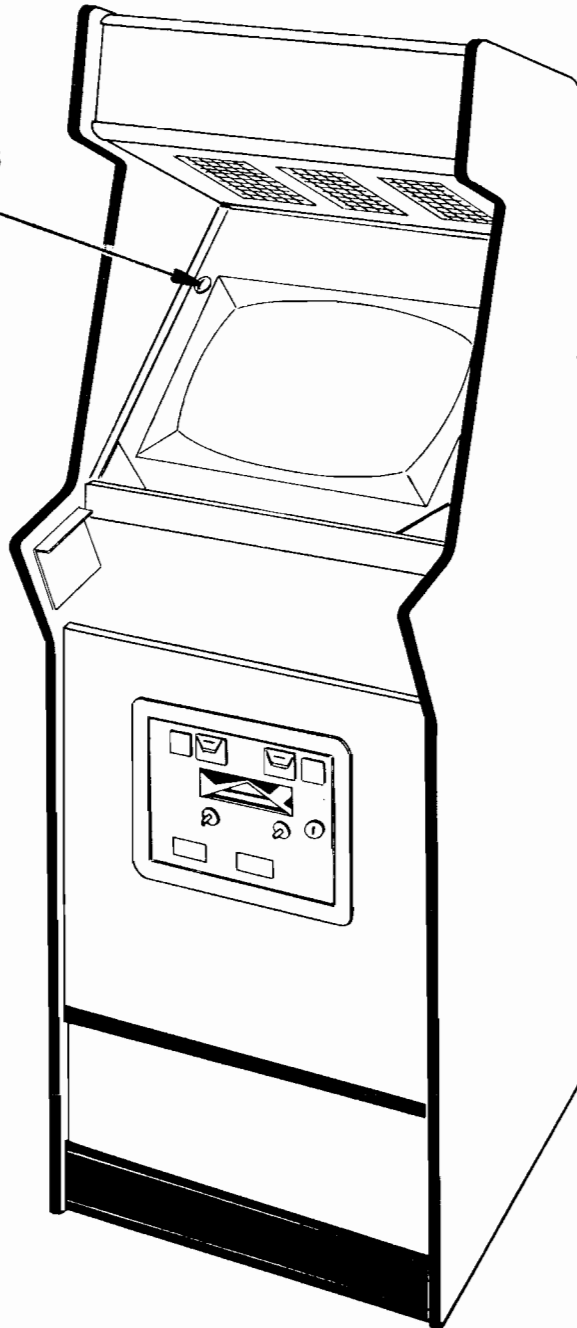

FIG. 16

MINI

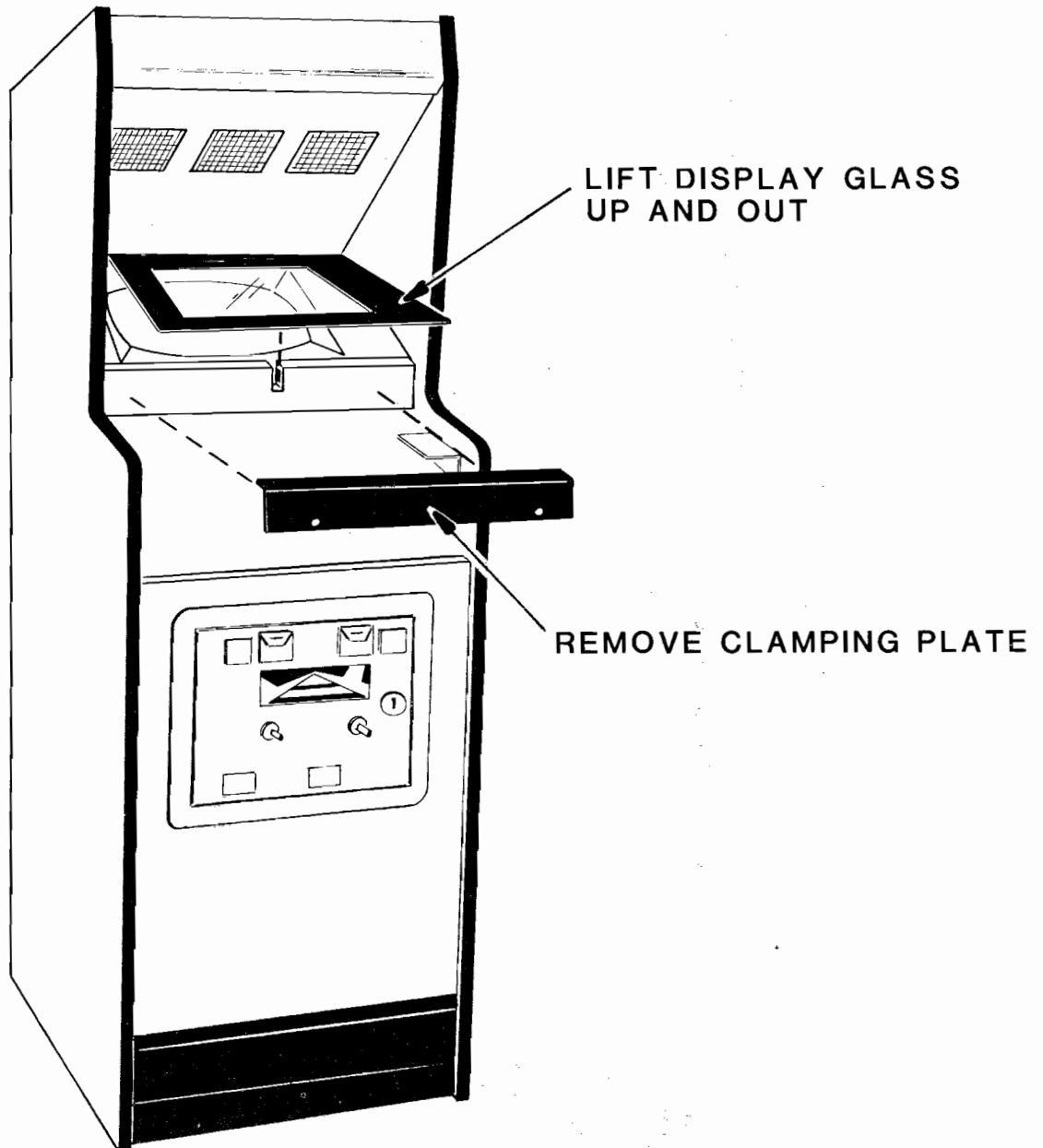

FIG. 17

MINI

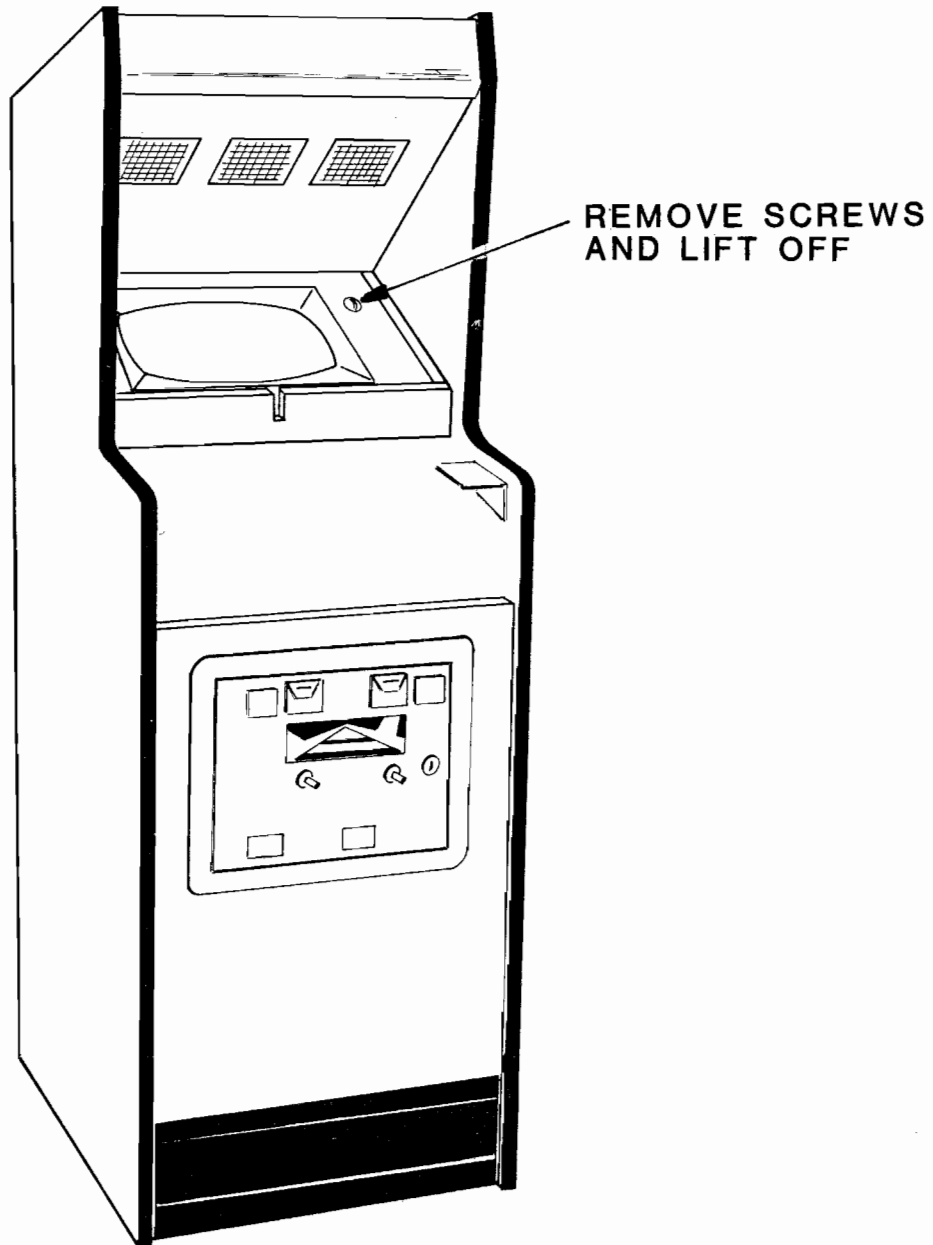
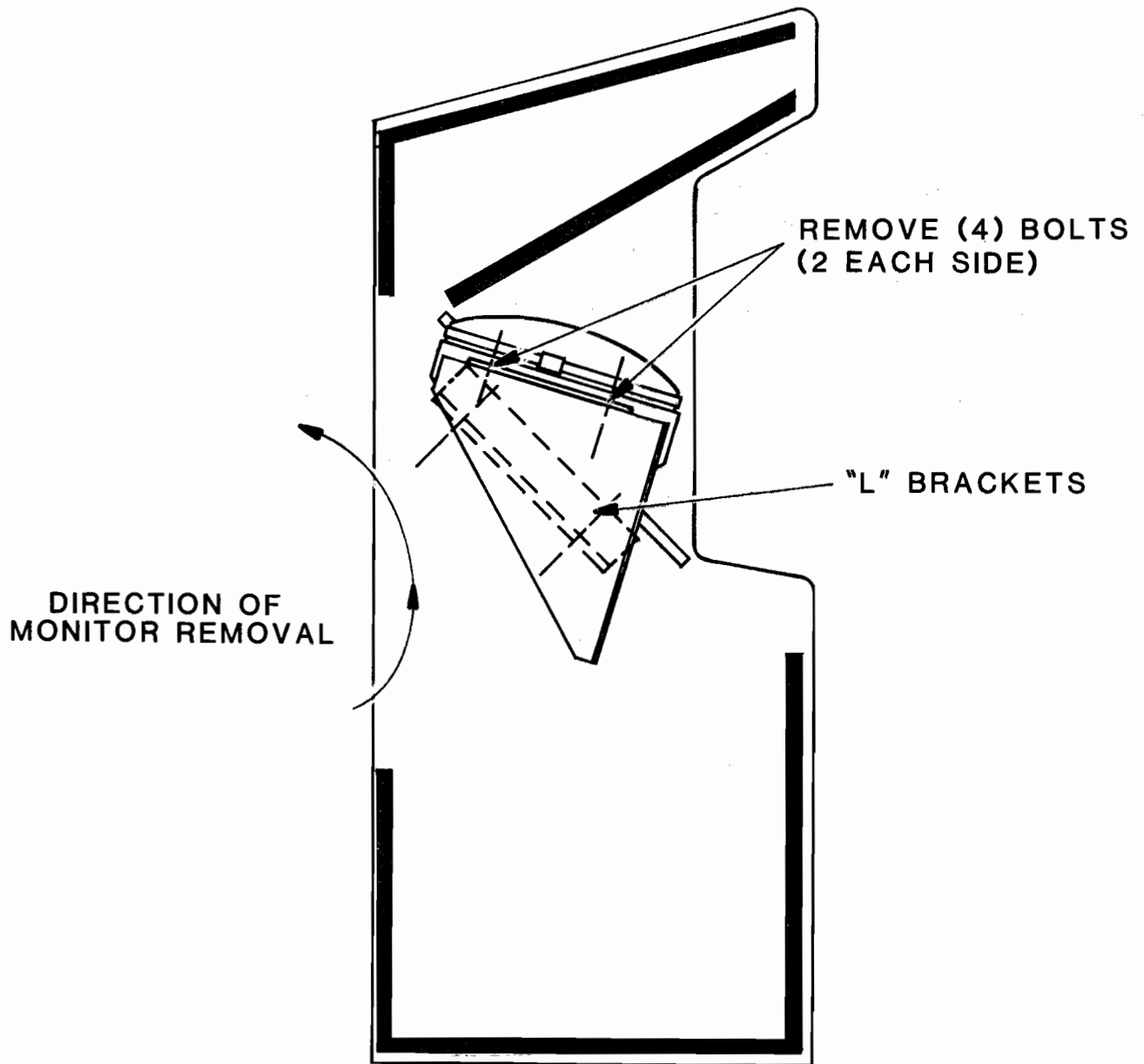

FIG.18
UPRIGHT
MINI



3. Cocktail Table model:
 - a. Turn the power off to the game.
 - b. Open the coin box door and release the two latches indicated in Figure 19.

CAUTION: The right hand latch is close to HIGH VOLTAGE on the monitor.

 - i. Once they're released, unhook them from their latch plates.
 - c. Grasp the table top at "A" and open it as indicated in Figure 19.

CAUTION: Due to the weight of the monitor, EXTREME CARE MUST be taken when opening the cabinet.
 - d. Remove the screws which hold the table top glass clamps in place.
 - e. Remove the table top glass.
 - f. Lift out the T.V. bezel assembly.
 - g. Completely disconnect the T.V. monitor from all its cabling. **DON'T FORGET THE CHASSIS GROUND WIRE.**
 - h. Remove the screws holding the T.V. monitor chassis to the "L" by the door hinge(s). See Figure 20.
 - i. Close the Cocktail Table top and re-latch it.
 - j. Remove the screws which secure the T.V. monitor mounting brackets to the edges of the slot cut in the table top. See Figure 20.
 - k. Pry up the end of each monitor mounting bracket with a screwdriver or similar tool until you can grasp them both.
 - l. Lift the T.V. monitor straight up and out of the table top being *very careful* not to bump the neck of the picture tube.
 - m. To reinstall the T.V. monitor assembly, reverse this procedure.
 - i. Be sure to check the clearance of the "L" brackets **BEFORE** setting the monitor into the table top.
 - n. After replacing a T.V. monitor, be sure to run the game Self-Test.

FIG. 19
COCKTAIL

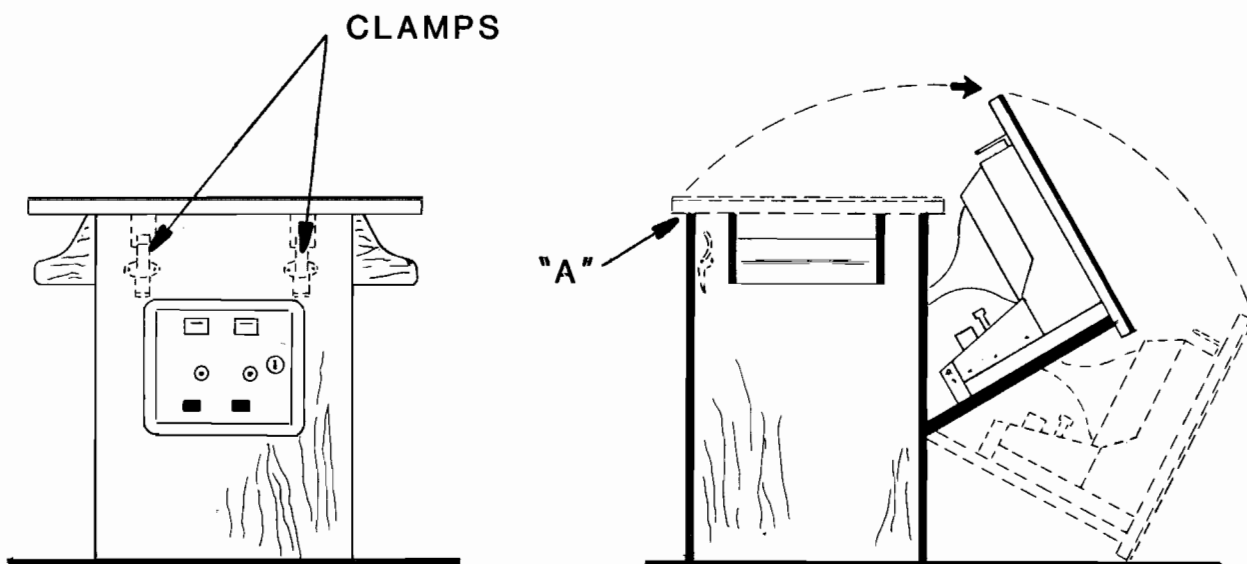
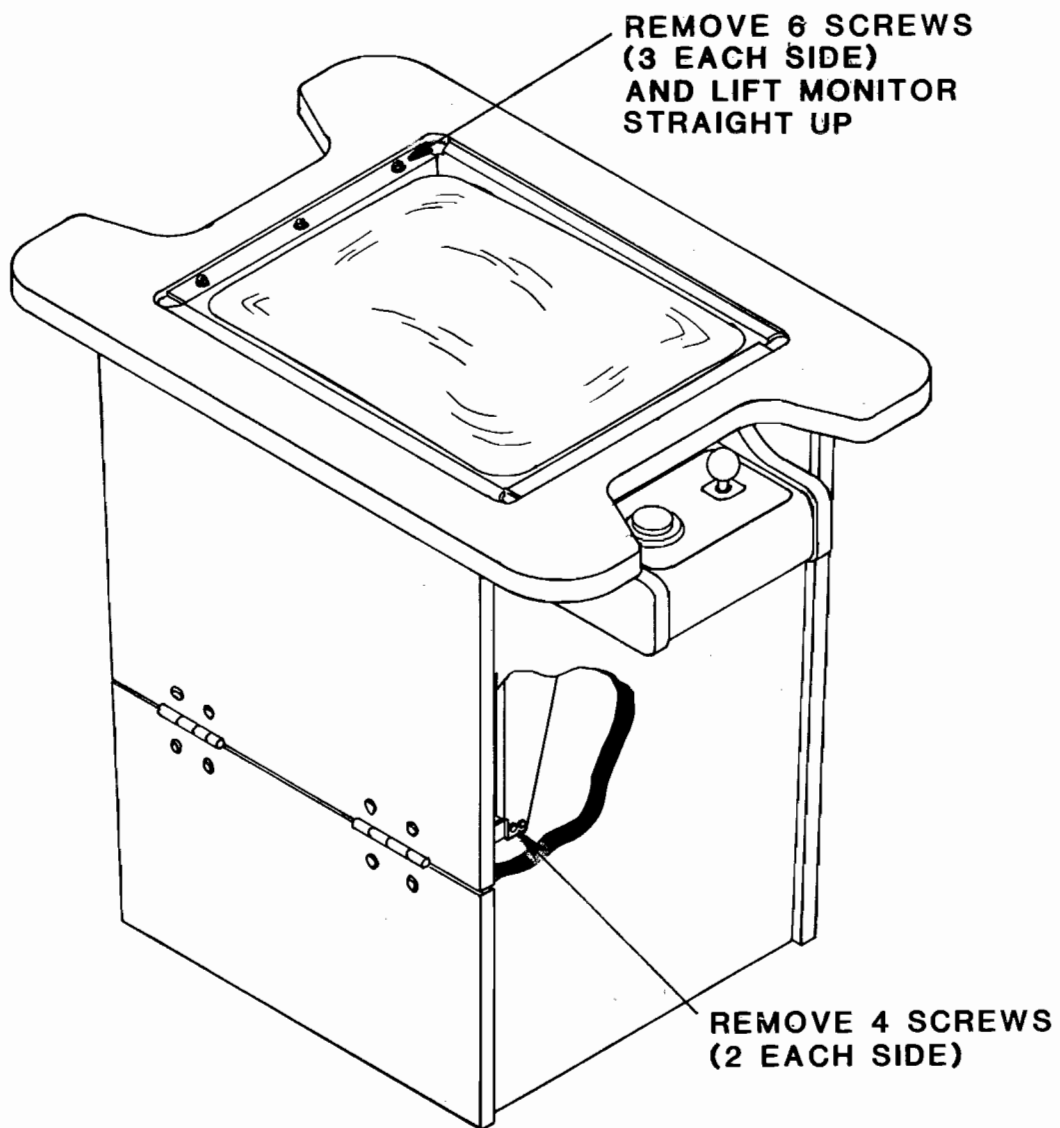

FIG.20
COCKTAIL



F. PRINTED CIRCUIT BOARD (P.C.B.) REPLACEMENT — SEE FIGURE 21:

1. Upright model:

- a. Turn the power off to the game.
- b. Unlock and open the coin door.
- c. Reach inside and release the games front access door locking latches. See Figure 21 and drawing on top of coin box lid.
- d. Slide out the utility shelf. See Figure 22.
 - i. Mounted on the utility shelf is the commercial card rack with six cards in it.
 - ii. Also mounted on the utility shelf, next to the commercial card rack, is its power supply P.C.B.
- e. To remove the cards from the commercial card rack, simply lift on their extractors and remove them. See Figure 23.

NOTE: BEFORE removing the "GAME P.C.B.", be sure to disconnect it from all its cabling.

- f. To remove the power supply P.C.B. for the commercial card rack:
 - i. Disconnect it from all its cabling. See Figure 24.
 - ii. Remove the screws which secure the top P.C.B. support to its mounting bracket. (Be careful not to lose the washers.) See Figure 24.
- g. To reinstall the above P.C.B.'s, reverse this procedure.

NOTE: P.C.B.'s are all keyed and will ONLY fit into their connectors ONE way without forcing them.

2. Mini model:

- a. Turn the power off to the game.
- b. Open the access door at the back of the game.
- c. To remove the power supply for the commercial card rack: (See Figure 25.)
 - i. Remove the P.C.B. supports indicated in the above figure.
 - ii. Disconnect the P.C.B. from its cabling.
 - iii. Slide the P.C.B. out the back of the cabinet.
 - iv. To reinstall the power supply for the commercial card rack, reverse this procedure.

NOTE: P.C.B.'s are all keyed and will ONLY fit into their connectors ONE way without forcing them.

- d. To remove any of the P.C.B.'s from the commercial card rack: (See Figure 23.)
 - i. Lift up on the P.C.B. extractors as shown in the above figure.
 - ii. Now lift the loosened P.C.B. straight up and out.

NOTE: BEFORE removing the "GAME P.C.B.", be sure to disconnect it from all its cabling.

- iii. To reinstall the P.C.B.'s, reverse this procedure.

NOTE: P.C.B.'s are all keyed and will ONLY fit into their connectors ONE way without forcing them.

3. Cocktail Table model:

- a. Turn the power off to the game.
- b. Open the cabinet:
 - i. Open the coin box door and release the two latches indicated in Figure 26.

CAUTION: The right hand latch is close to HIGH VOLTAGE on the monitor.

 - Once they're released, unhook them from their latch plates.
 - ii. Grasp the table top at "A" and open it as shown in Figure 26.

CAUTION: Due to the weight of the monitor, EXTREME CARE MUST be taken when opening the cabinet.

FIG.21
UPRIGHT

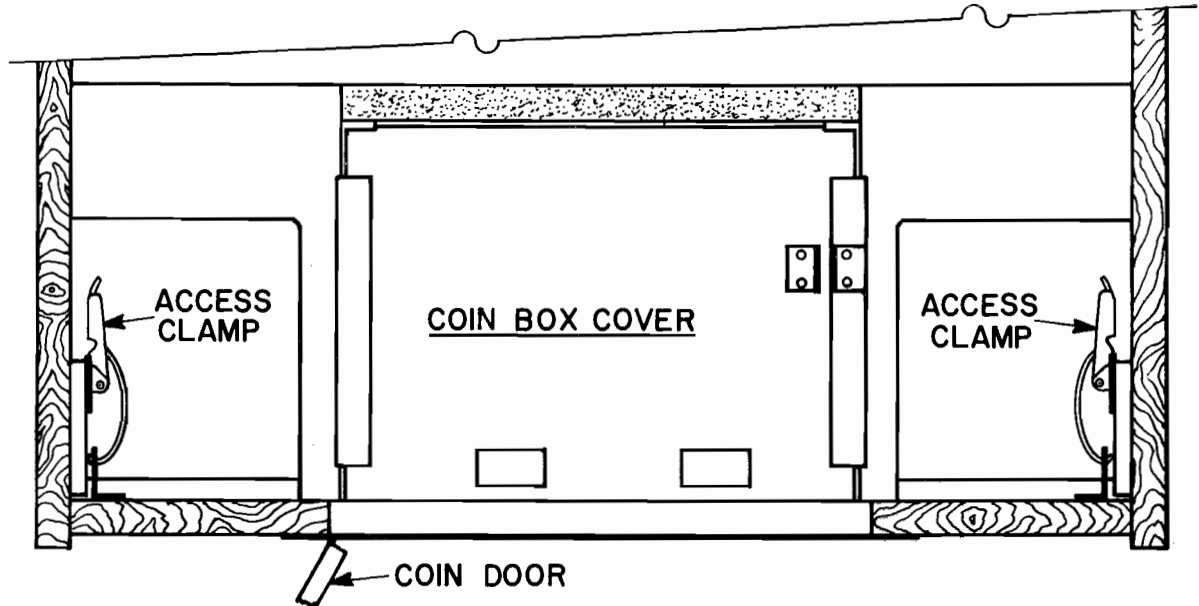

FOR SERVICE ACCESS

1. OPEN LOWER SERVICE DOOR BY RELEASING TWO ACCESS CLAMPS. (LOCATIONS AS SHOWN)
2. REMOVE TWO RED SHIPPING BRACKETS AND SLIDE OUT SERVICE SHELF.

FIG.22
UPRIGHT

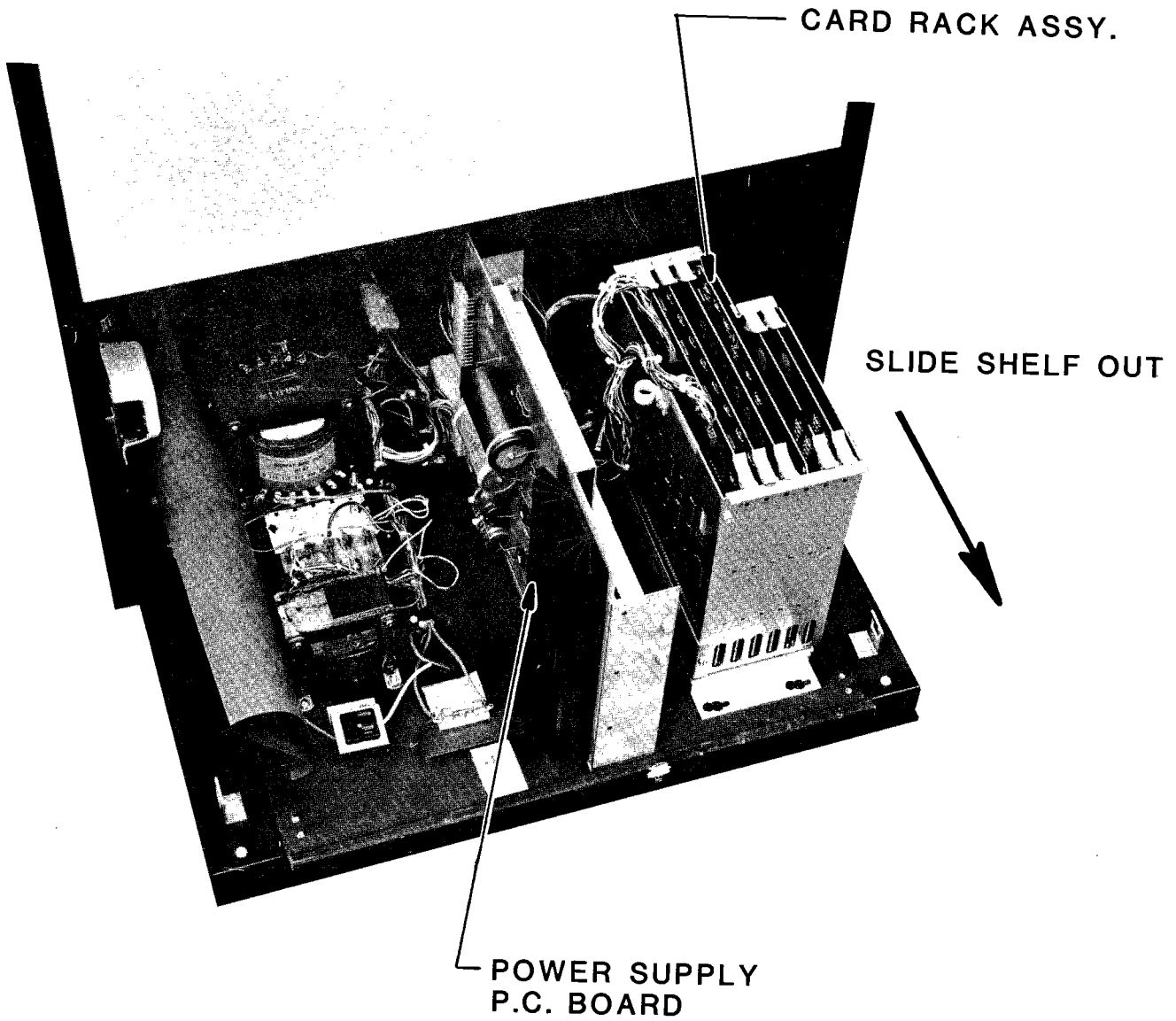
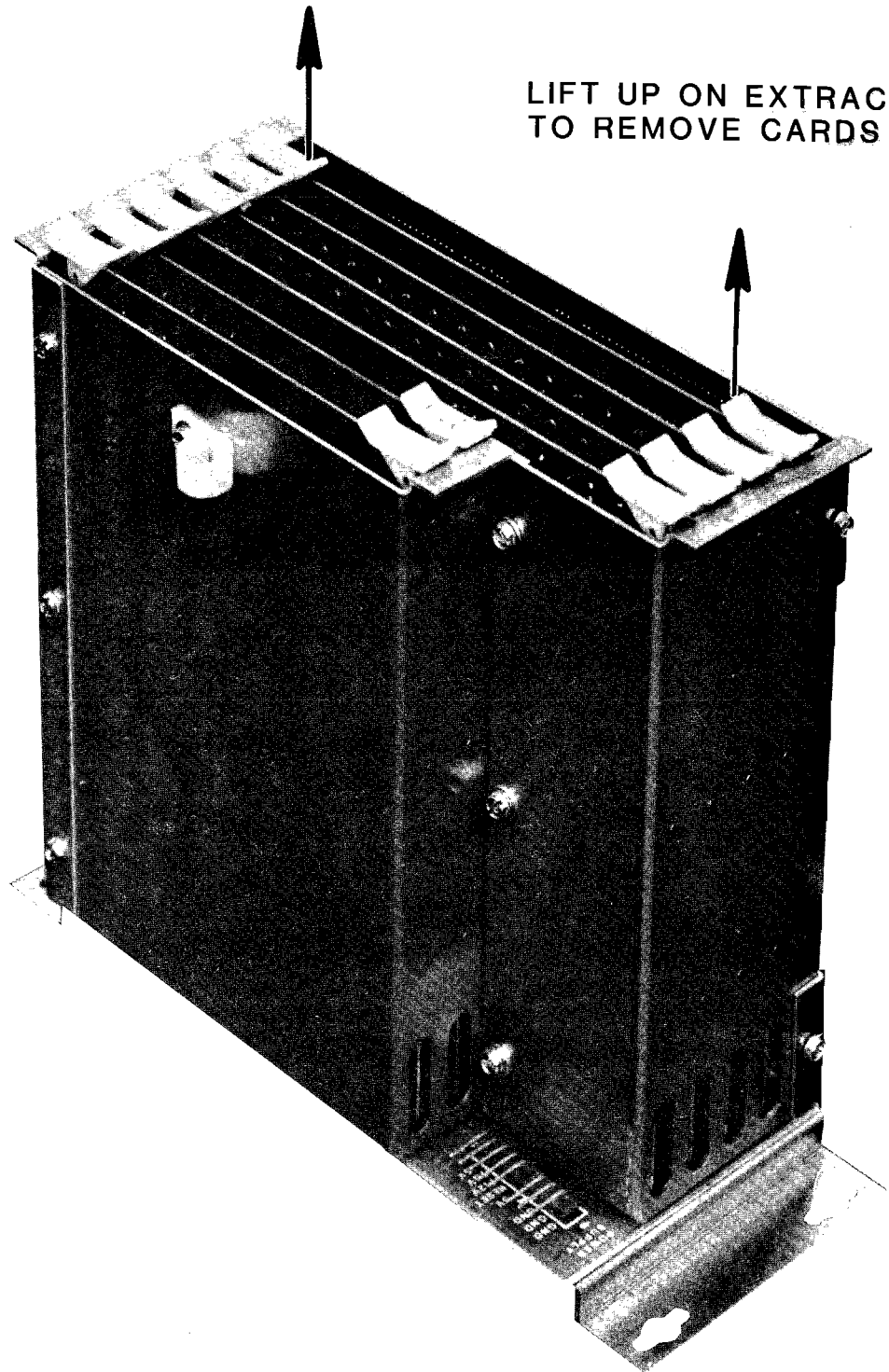

FIG.23
CARD RACK



**LIFT UP ON EXTRACTORS
TO REMOVE CARDS**

FIG.24
UPRIGHT

DISCONNECT POWER SUPPLY
FROM CABLING

REMOVE (2) SCREWS
FROM TOP
P.C.B. SUPPORT

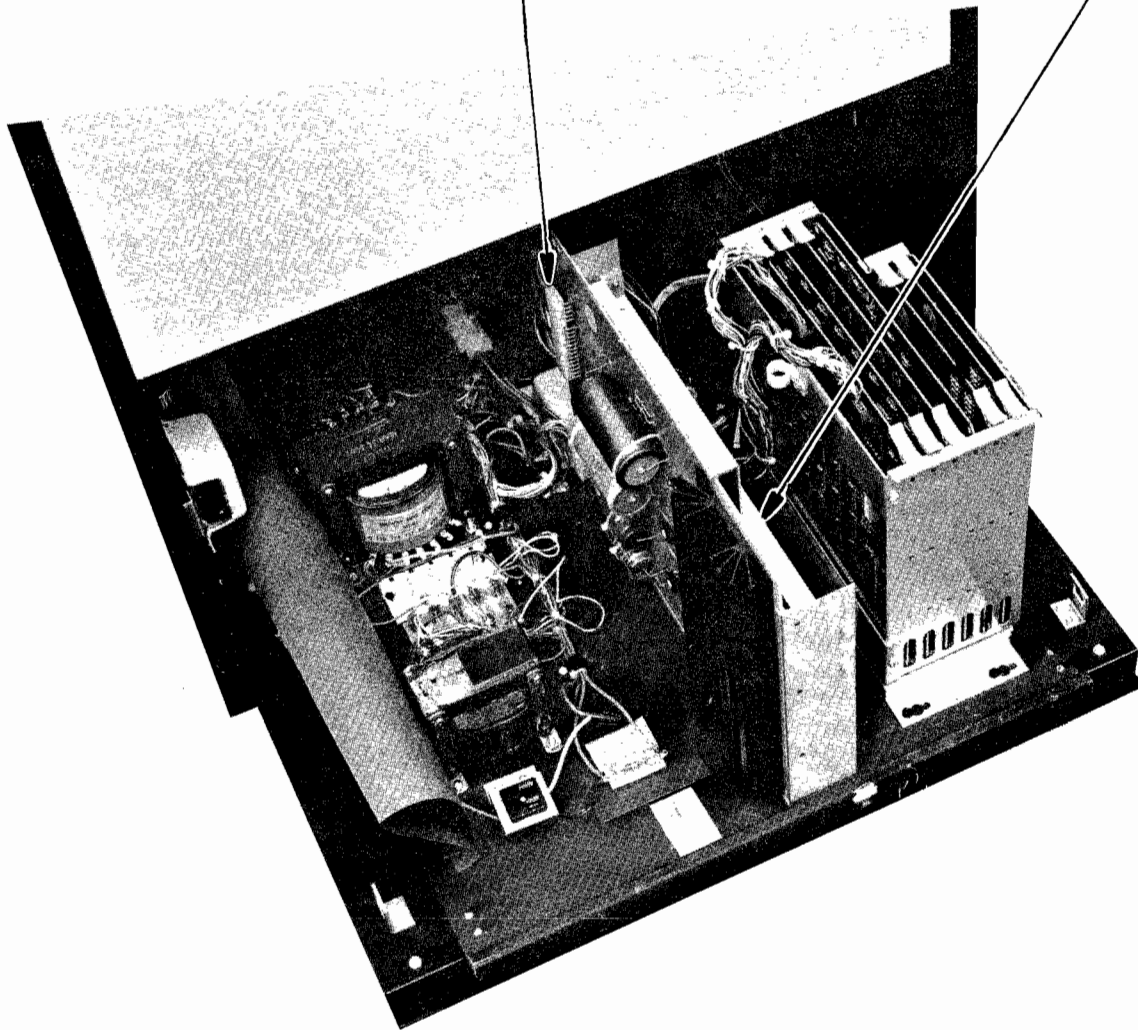

FIG.25

MINI

**POWER SUPPLY
P.C. BOARD**

CARD RACK ASSY.

REMOVE CABLING

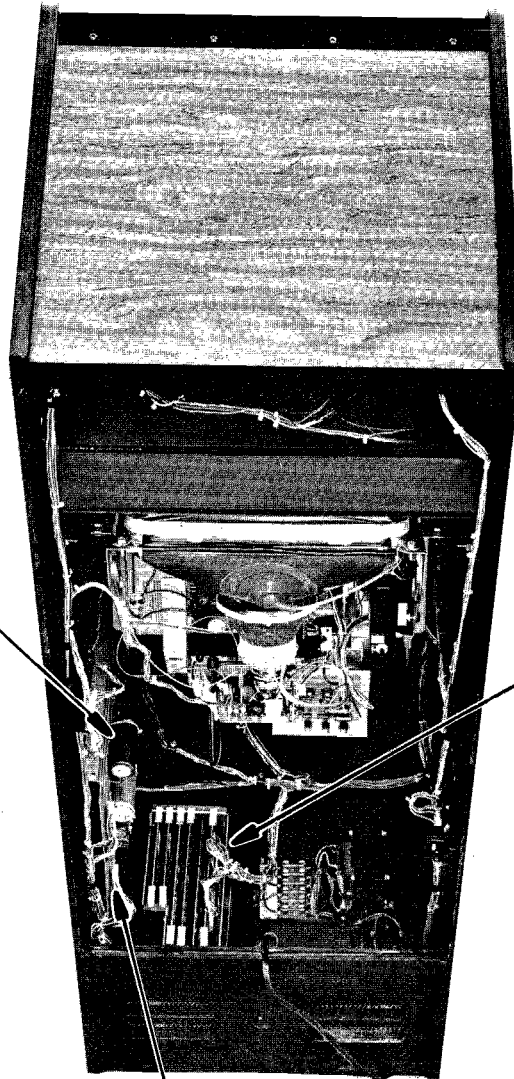

- c. To remove the power supply for the commercial card rack: (See Figure 27.)
 - i. Disconnect it from all its cabling.
 - ii. Remove the two smallest P.C.B. supports.
 - iii. Once these supports are removed, the power supply for the commercial card rack can be lifted out of the cabinet.
 - iv. To reinstall the power supply for the commercial card rack, reverse this procedure.
- d. To remove any of the P.C.B.'s from the commercial card rack: (See Figure 23.)
 - i. Lift up on the P.C.B. extractors as shown in the above figure.
 - ii. Now lift the loosened P.C.B.'s straight up and out.
 - NOTE: BEFORE removing the "GAME P.C.B.", be sure to disconnect it from all its cabling.
 - iii. To reinstall the P.C.B.'s, reverse this procedure.
 - NOTE: P.C.B.'s are all keyed and will ONLY fit into their connectors ONE way without forcing them.

FIG.26
COCKTAIL

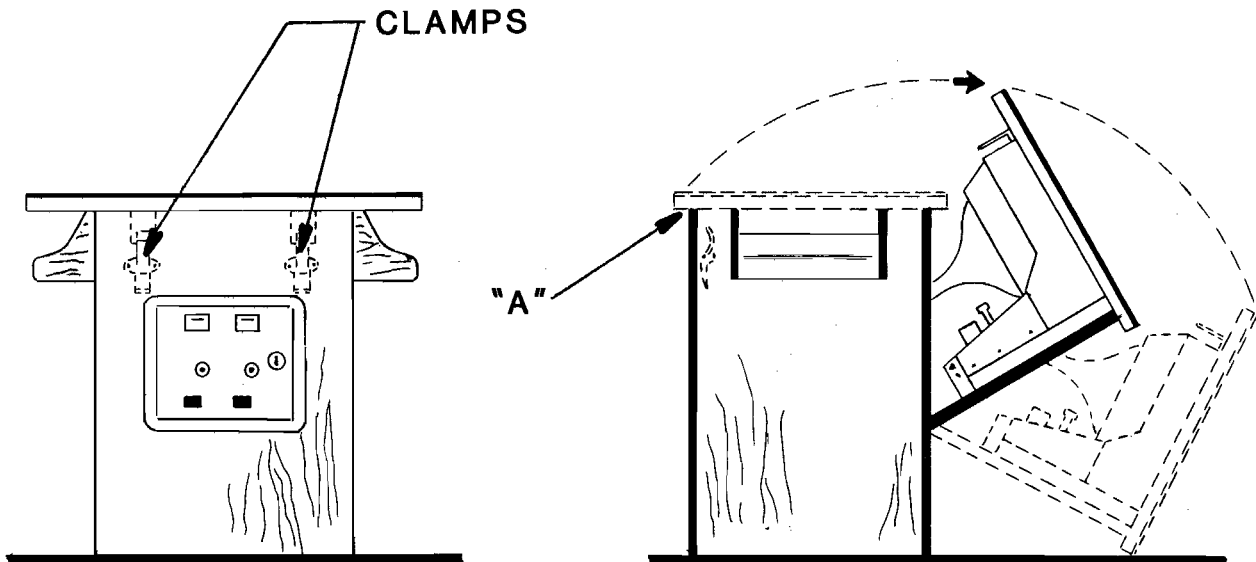

G. OPENING THE ATTRACTION PANEL — SEE FIGURE 28:

- 1. Upright model:
 - a. Turn the power to the game off.
 - b. Remove the screws from the top of the top bracket. See Figure 28.
 - c. Remove the top bracket and slide up the attraction panel. This exposes the attraction panel fluorescent light tube and its mounting bracket assembly. See Figure 28.
 - d. The fluorescent light tube may be replaced at this time. **BE CAREFUL NOT TO DROP IT.**
 - WARNING: If you drop a fluorescent light tube and it breaks, **IT WILL IMplode!** Shattered glass can fly six feet or more from the implosion. Use care when replacing any fluorescent light tube.
 - e. Replacing the fluorescent light tube starter — See Figure 29:
 - i. Be sure that power to the game has been turned off.
 - ii. Reach behind the mounting bracket assembly, grasp the starter, give it a quarter turn, and remove it from its socket.
 - iii. To replace the fluorescent light tube starter, reverse this procedure.

FIG.27
COCKTAIL

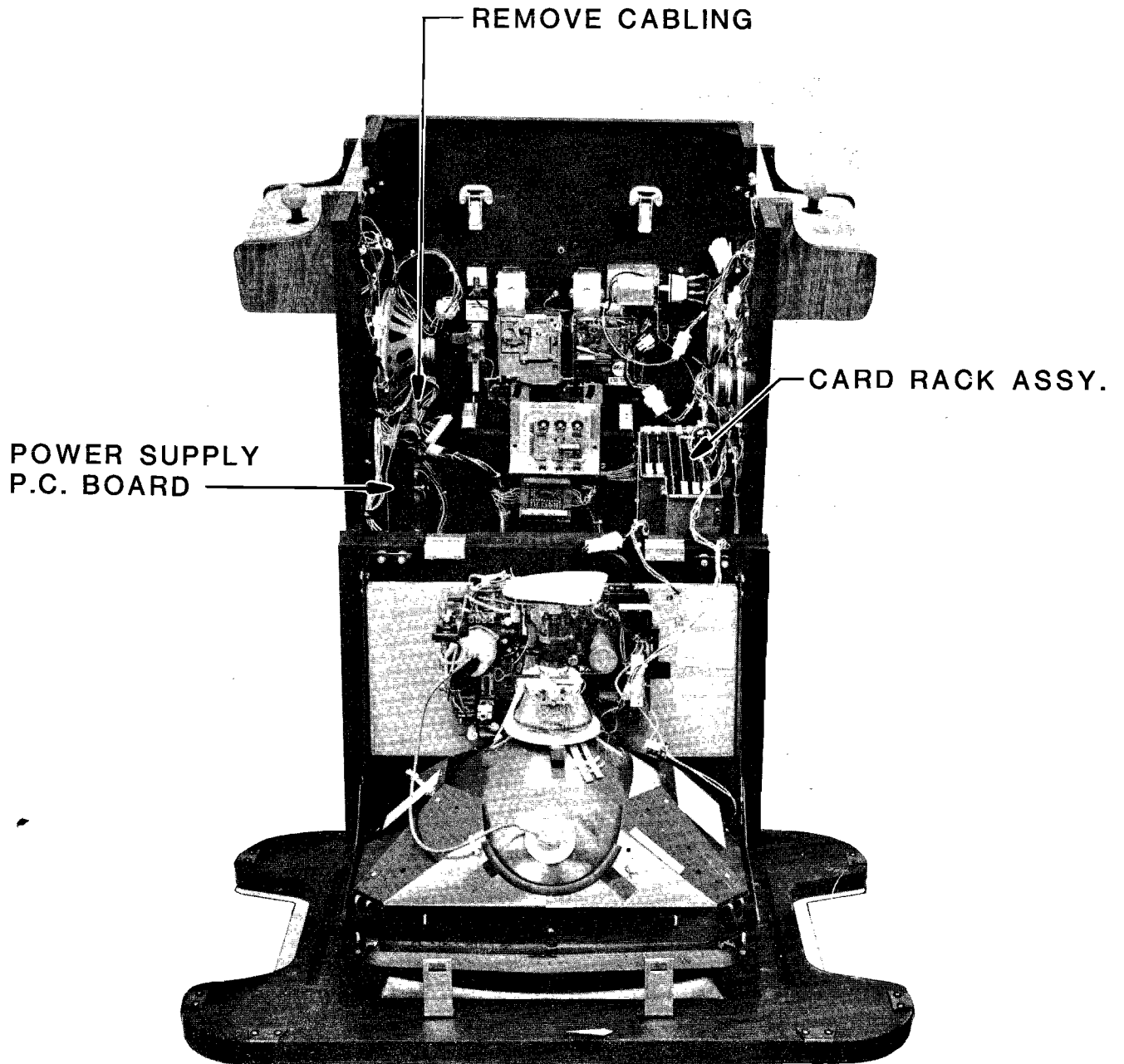

FIG.28
UPRIGHT

SLIDE ATTRACTION
PANEL UP

REMOVE (3)
SCREWS



FIG.29
UPRIGHT

1/4 TURN
TO REPLACE



FLORESCENT
TUBE STARTER



- f. Removal and replacement of the fluorescent light tube mounting bracket assembly — See Figure 30:
 - i. Be sure the power to the game is off.
 - ii. Disconnect the mounting bracket assembly from its cabling.
 - iii. Support the assembly with one hand while removing the right and left hand mounting screws. See Figure 30.
 - iv. The fluorescent light tube mounting bracket assembly is now free and can be removed from the cabinet.
 - v. To reinstall the fluorescent light tube mounting bracket assembly, reverse this procedure.
- g. Replacing the speaker(s) — See Figure 31:

NOTE: In order to replace the speaker(s), the attraction panel and the fluorescent light tube mounting bracket assembly MUST be removed first.

 - i. Be sure the power to the game is off.
 - ii. Completely disconnect the speakers from their cabling. See Figure 31.
 - iii. Remove the nuts and bolts securing the speaker(s).
 - iv. Slide the speaker(s) out through the attraction panel opening.
 - v. To reinstall the speaker(s), reverse this procedure.

2. Mini model — See Figure 32.

- a. Turn the power off to the game.
- b. Remove the screws from the top of the top bracket.
- c. Remove the top bracket and slide up the attraction panel. This exposes the attraction panel light bulbs and their mounting board.
- d. To service the light bulbs and their mounting board:
 - i. Turn the power to the game back on so you can see which bulbs are burnt out.
 - ii. Mark the burnt out bulbs and turn the power to the game off again.
 - iii. To replace the burnt out bulbs, grasp them gently and pull straight out.
 - The new bulbs are gently pushed into the empty sockets.
 - iv. To completely remove the light bulb mounting board:
 - Open the cabinet rear access door and disconnect it from its cabling.
 - Remove the two screws that hold the mounting board to the cabinet (one on the right side and one on the left side of the panel).
 - Gently slide the mounting board out the front of the cabinet being careful not to catch its cable on anything.
- e. Replacing the speaker(s) — See Figure 33.
 - i. Be sure the power is off to the game.
 - ii. Disconnect the speaker(s) from its cabling.
 - iii. Remove the nuts and bolts securing the speaker(s) to be replaced.
 - iv. Slide the speaker(s) out through the rear access door.
- f. To reinstall any of the parts removed in the above steps, simply reverse the procedure that pertains to that part(s).

H. COIN DOOR MAINTENANCE

1. Periodically the metal coin acceptor mechanism must be removed from the coin door and cleaned.
 - a. Make sure the power is turned off to the game.
 - b. Unlock and open the coin door.
 - c. Remove the coin acceptor mechanism as shown in Figure 34.
 - i. Push down on the two spring loaded latches.
 - ii. While holding the latches down, pull the top of the coin acceptor mechanism toward you.
 - iii. Release the latches and lift out the mechanism.

FIG.30
UPRIGHT

**REMOVE
(2) SCREWS**

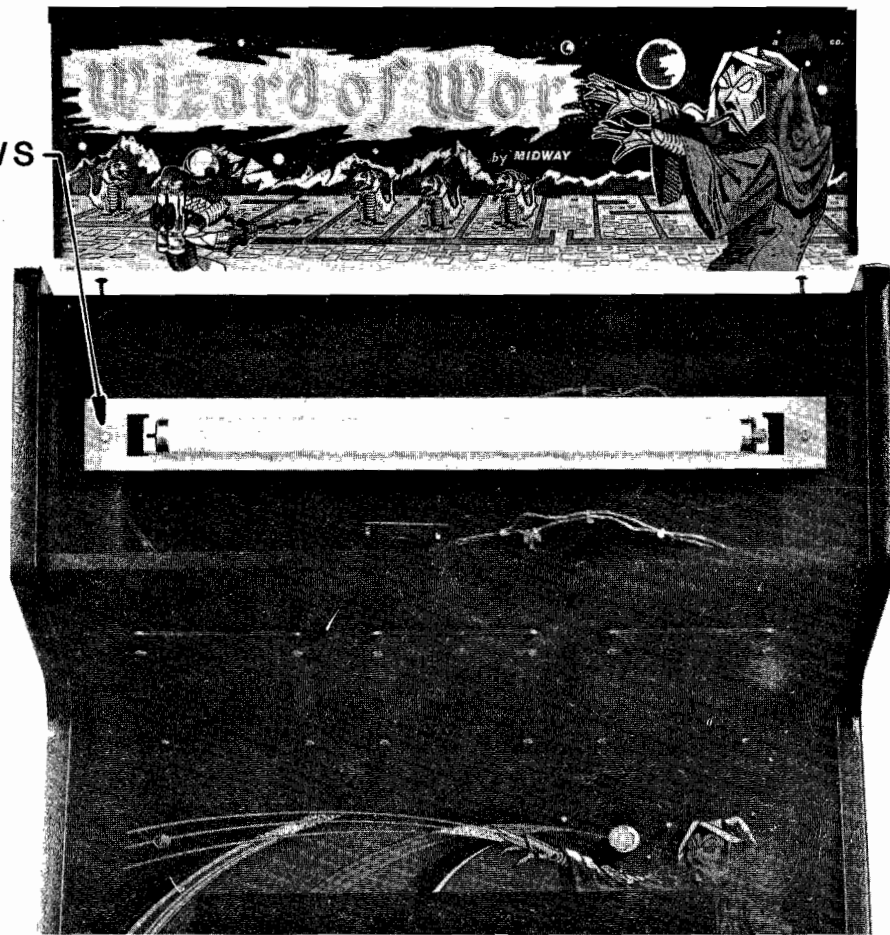

FIG.31
UPRIGHT

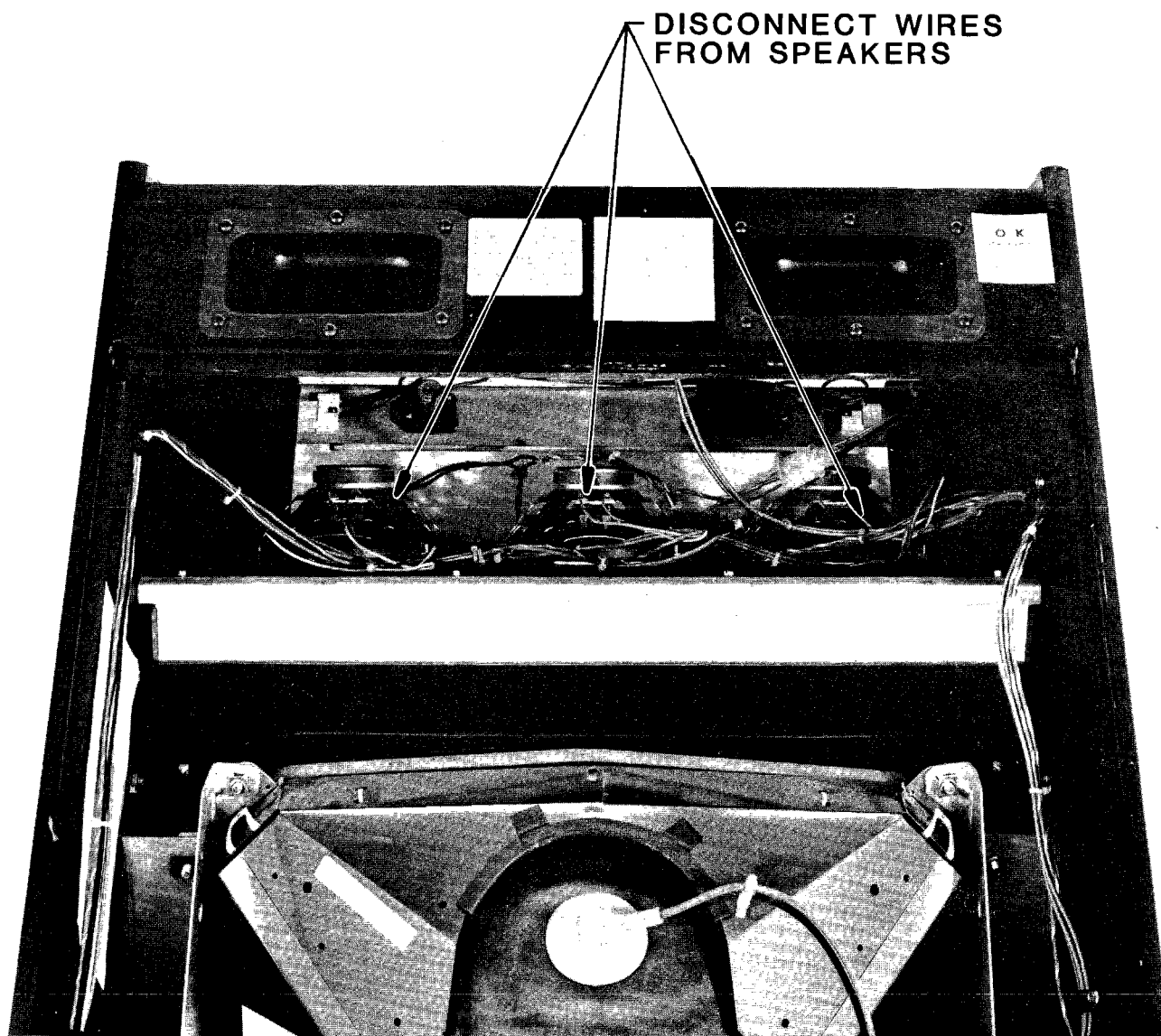

FIG.32

MINI

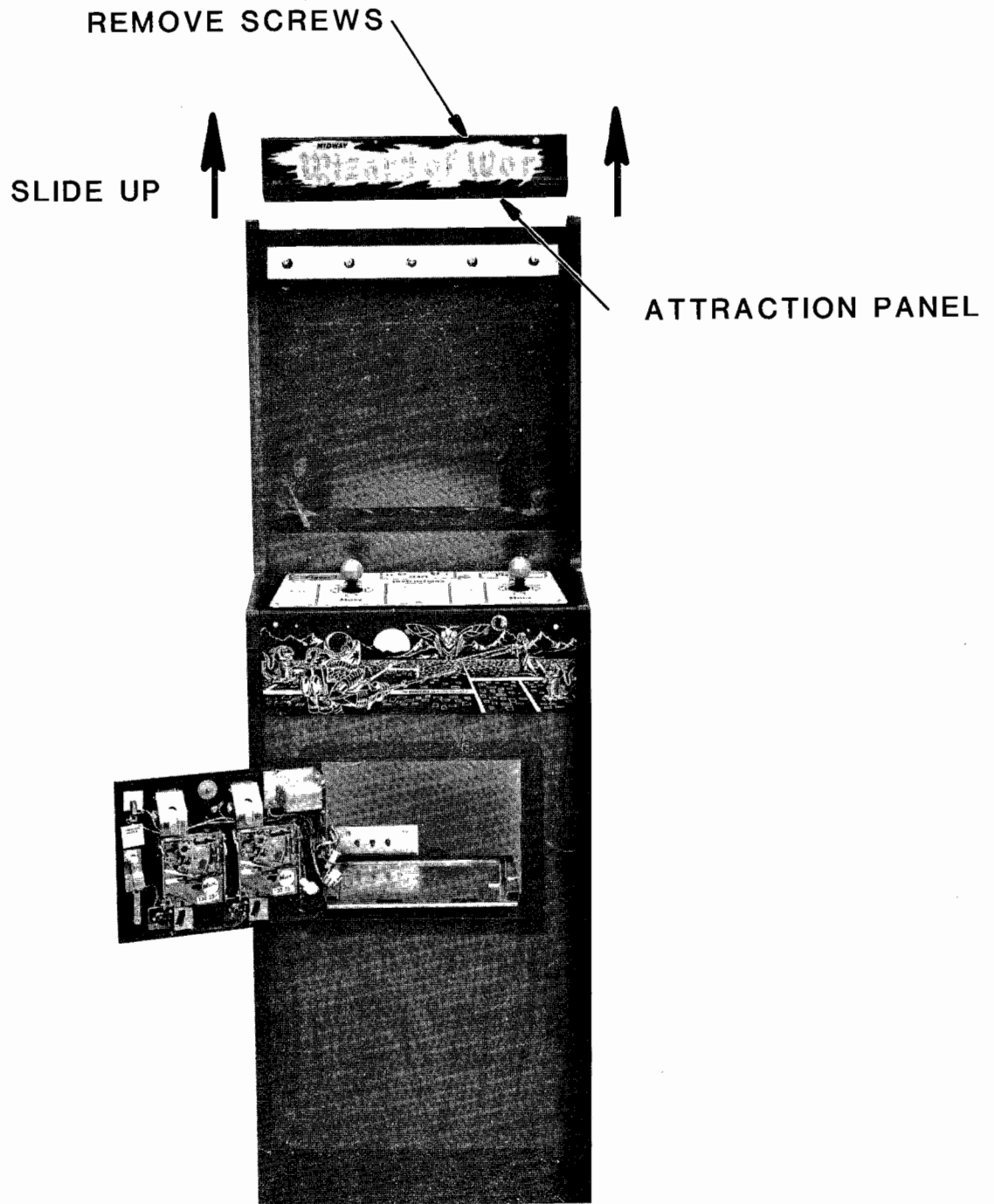
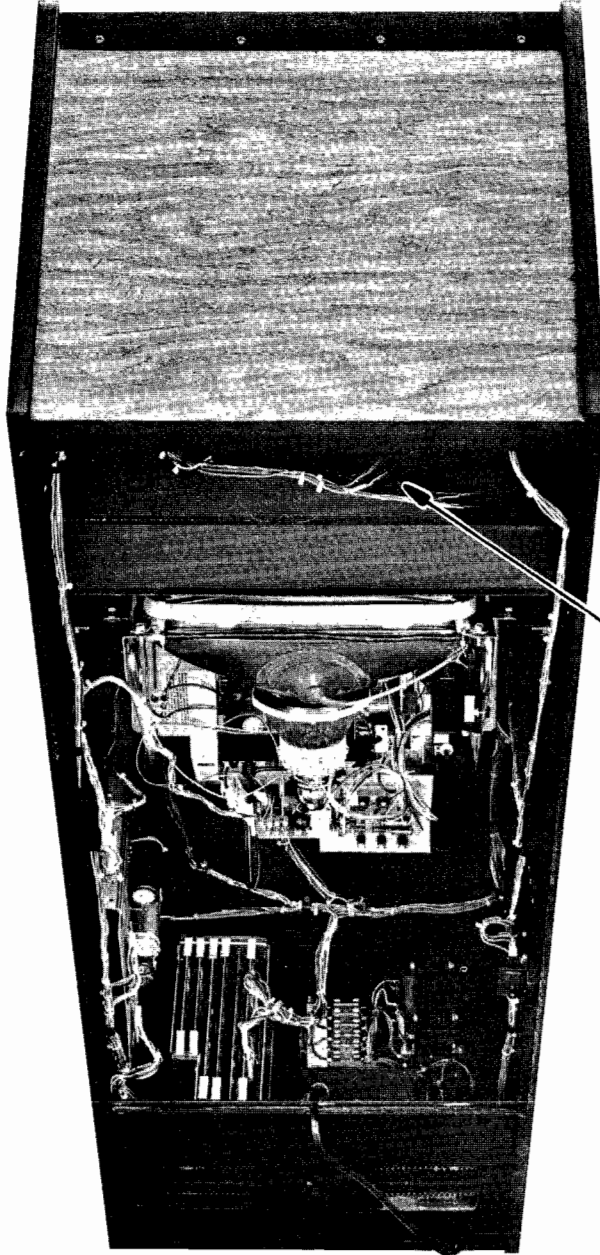

FIG.33

MINI



**DISCONNECT WIRES
FROM SPEAKERS**

- d. Clean the magnet of all foreign particles. See Figure 35.
 - i. This may be accomplished by swinging the gate open as shown in the above figure.
 - e. Remove the cradles and undersize levers and clean the bushings.
 - i. A pipe cleaner makes a good bushing cleaner.
 - ii. Also clean the pivot pin.
 - f. Whenever needed, the coin acceptor should be cleaned with hot water and cleanser in the following manner:
 - i. Place the acceptor in boiling water for about ten (10) minutes.
CAUTION: BE CAREFUL NOT TO BURN YOURSELF.
 - ii. Next, use a brush and kitchen cleaner to remove all remaining foreign matter from the unit.
 - iii. Rinse the coin acceptor in clean boiling water.
 - iv. Dry the coin acceptor thoroughly by using filtered compressed air to blow it dry.
NOTE: The reason we recommend boiling water instead of cold water is that it evaporates faster than cold water and speeds the drying time.
 - g. To lubricate the coin acceptor:
 - i. Use ONLY powdered graphite and put in ONLY on the moving parts of the coin acceptor. These parts are called out in Figure 36.
 - ii. Be extremely careful to keep the powdered graphite away from the paths traveled by the coins.
WARNING: DO NOT use oil to lubricate the coin acceptor.
 - h. Check the coin chute for obstructions such as: paper, gum, etc.
 - i. Reinstall the coin acceptor to the coin door.
 - i. Place the two pegs at the coin acceptors base into their retaining slots.
 - ii. Now push the top of the coin acceptor toward the top of the coin door until it snaps in place.
 - j. Close and lock the coin door.
2. Plastic coin acceptor mechanisms must be removed periodically from the coin door and cleaned.
- a. Make sure the power to the game is turned off.
 - b. Unlock and open the coin door.
 - c. Remove the coin acceptor mechanism as shown in Figure 34.
 - i. Push down on the two spring loaded latches.
 - ii. While holding the latches down, pull the top of the coin acceptor mechanism toward you.
 - iii. Release the latches and lift out the mechanism.
 - d. Squeeze the two pins indicated in Figure 37 together to open the mechanism and break it down into its three basic parts.
 - i. Clean the mechanism in hot soapy water. It never rusts.
 - ii. Rinse the mechanism in clean hot water and allow it to dry.
 - iii. Reassemble the mechanism (it never needs lubrication).
 - e. Check the coin chute for obstructions such as: paper, gum, etc.
 - f. Reinstall the coin acceptor to the coin door.
 - i. Place the two pegs at the coin acceptors base into their retaining slots.
 - ii. Now push the top of the coin acceptor toward the coin door until it snaps in place and is held by the two spring loaded latches.
 - g. Close and lock the coin door.

NOTE: See Figure 38 for instructions on how to set the plastic coin acceptor mechanisms to either accept or reject Canadian quarters.

FIG.34
COIN ACCEPTOR REMOVALE

**PUSH DOWN
ON LATCHES**

PULL ACCEPTOR OUT

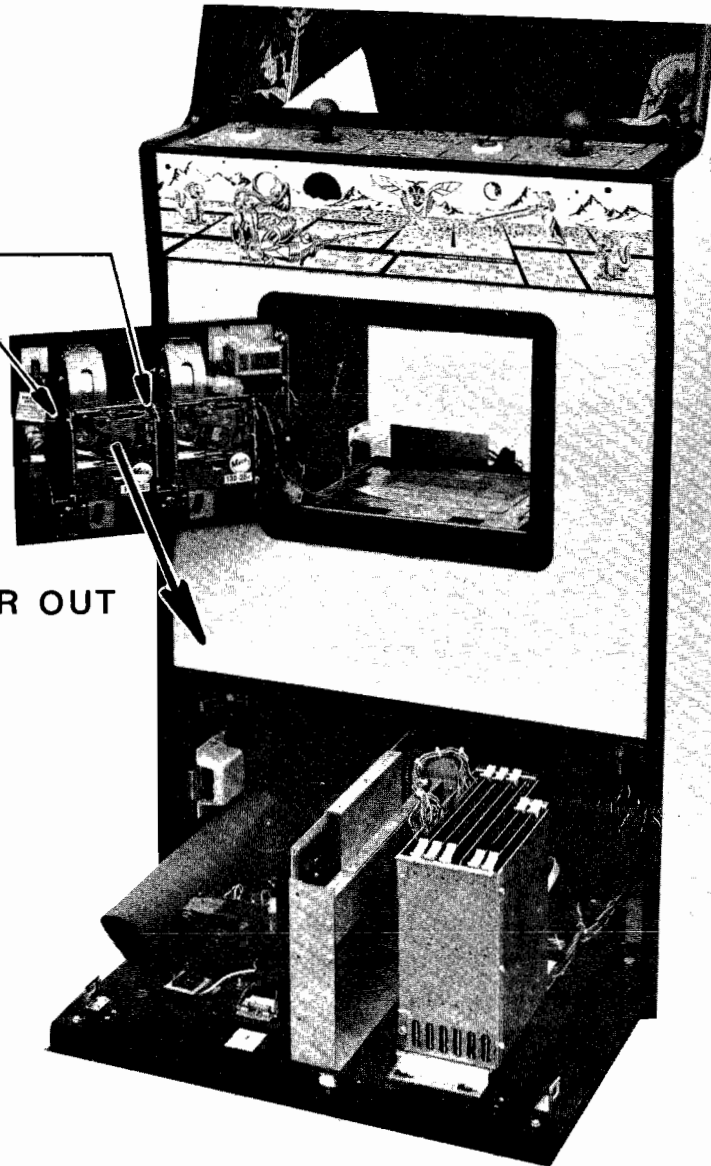

FIG.35

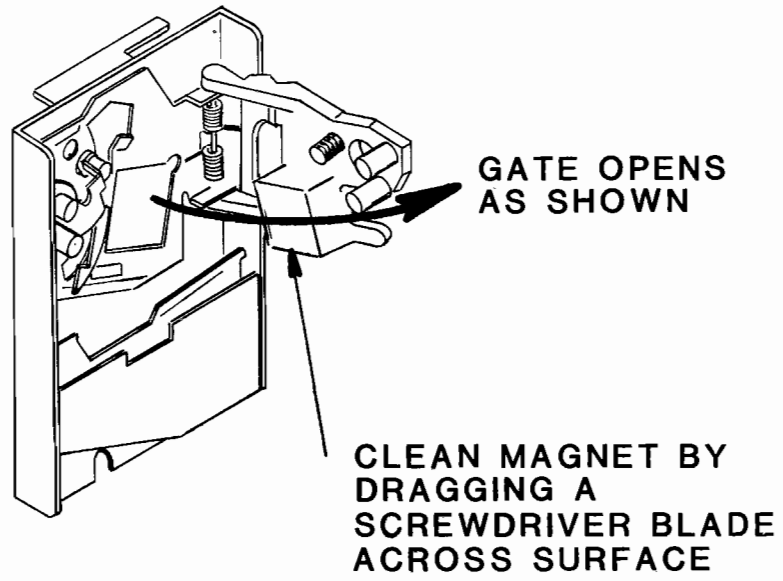

FIG.36

APPLY POWDERED GRAPHITE HERE

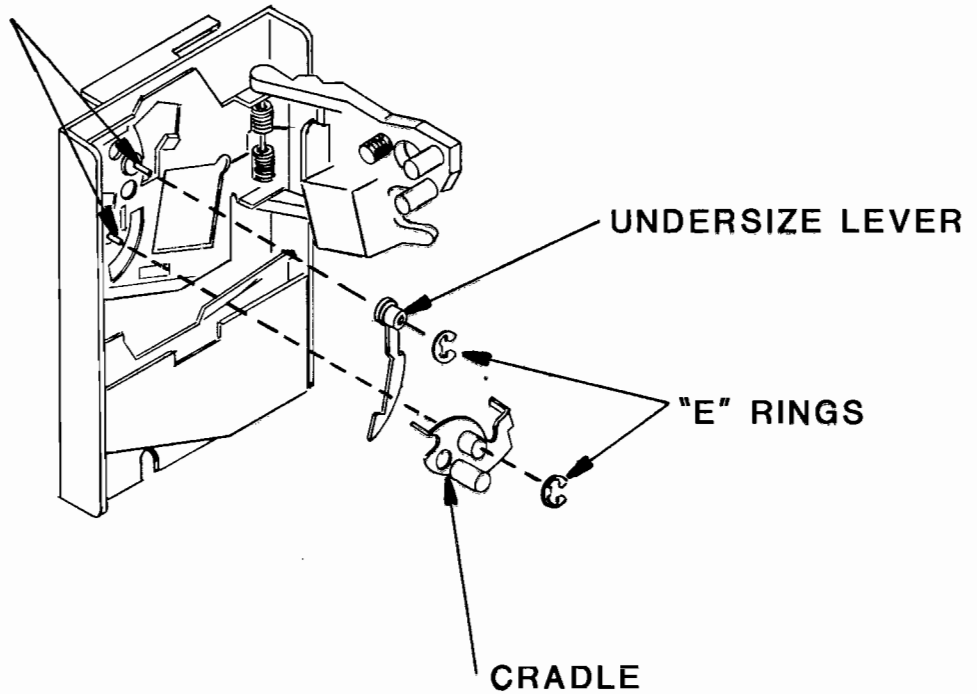
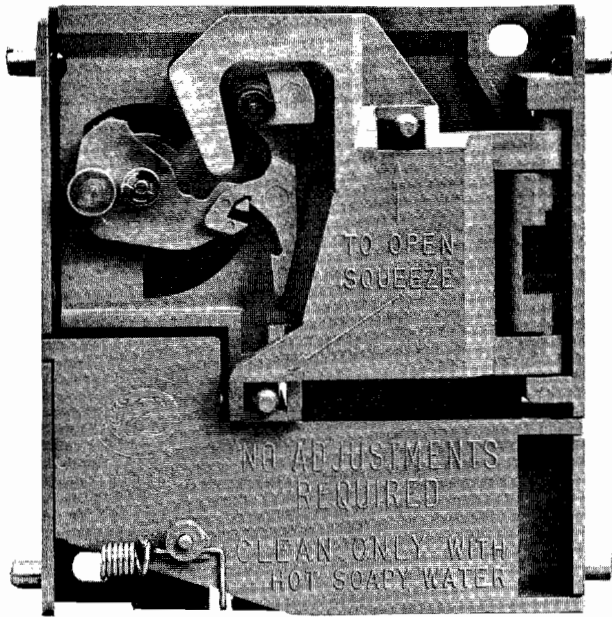
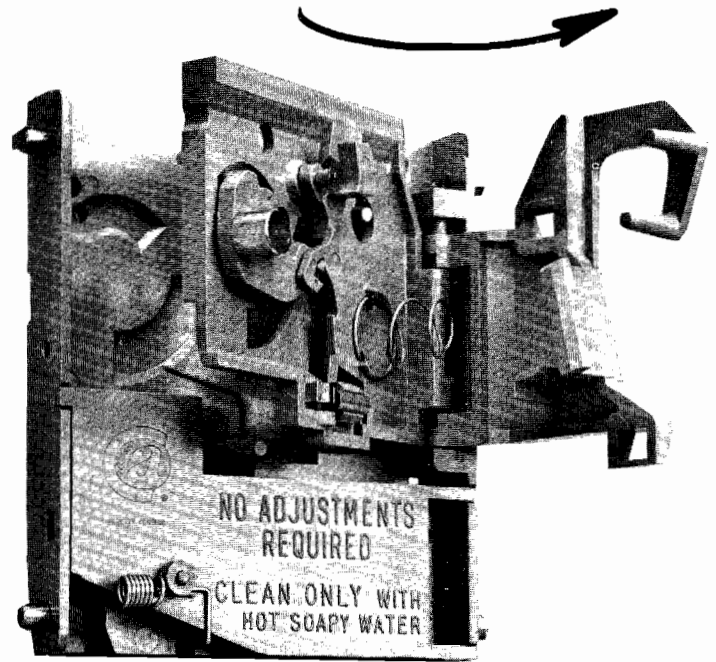

FIG.37



SQUEEZE PINS TOGETHER
TO UNLOCK



SWING BOTH GATES OPEN

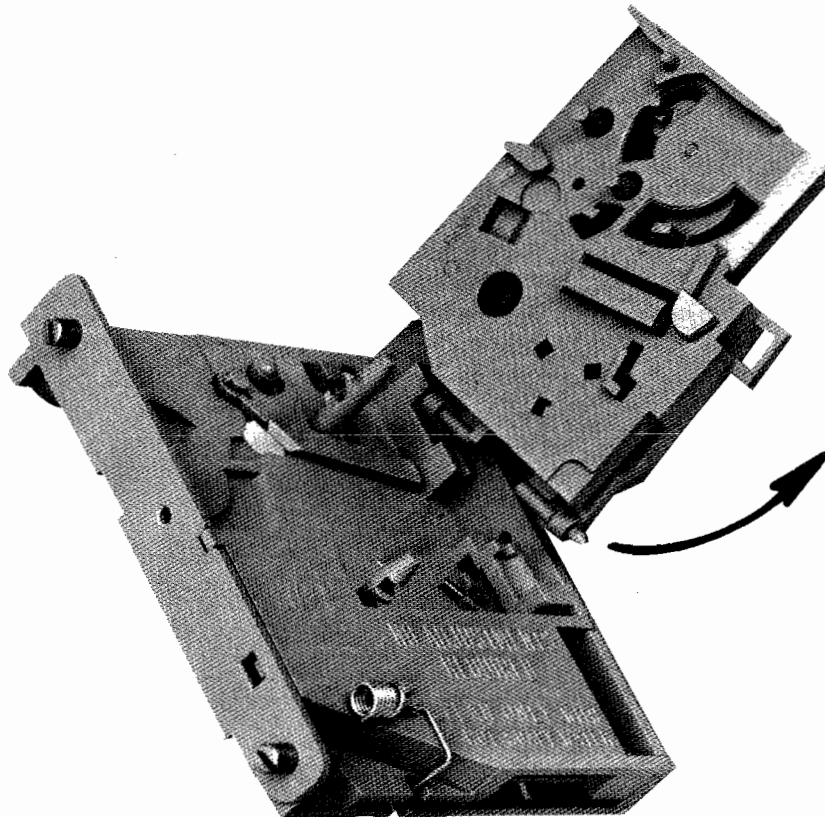

HOLDING BOTH GATES TOGETHER,
PUSH UP AND PULL OUT

FIG.38

**ACCEPTOR CAN BE SET TO ACCEPT U.S. QUARTERS ONLY
OR BOTH U.S. AND CANADIAN QUARTERS.**

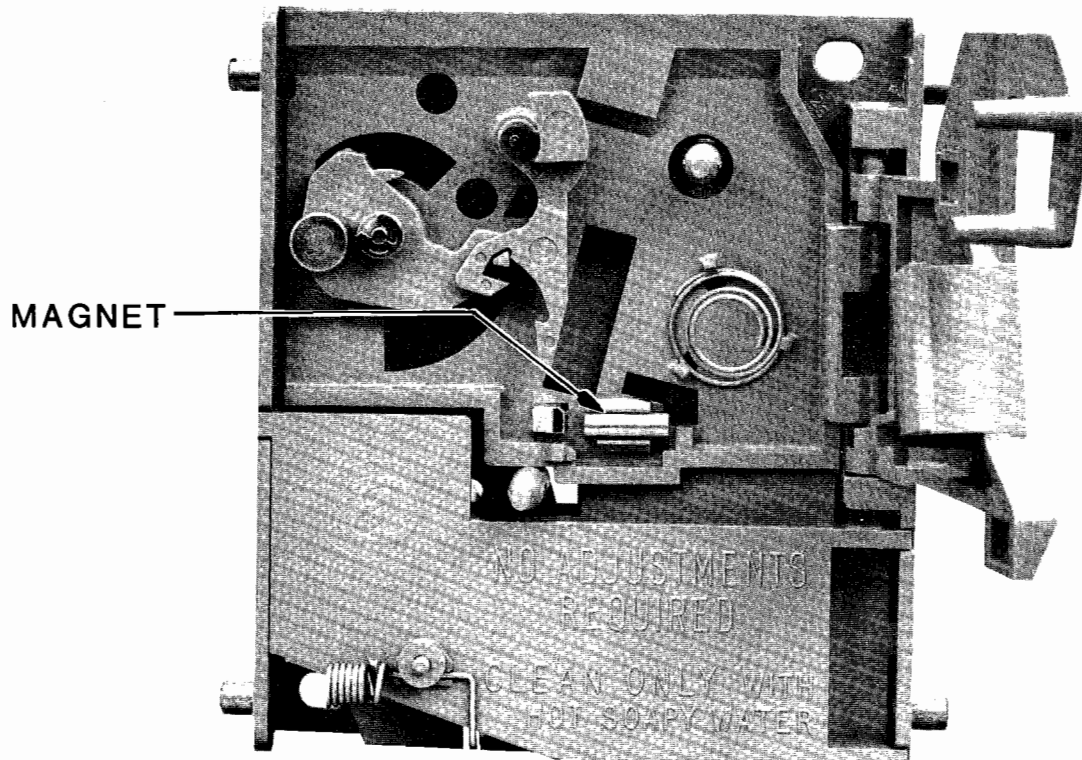

**SLIDE MAGNET TO EXTREME RIGHT
(AS PICTURED) TO ACCEPT BOTH
U.S. AND CANADIAN QUARTERS.**

**TO ACCEPT U.S. QUARTERS ONLY,
SLIDE MAGNET TO EXTREME LEFT.**

IV. ILLUSTRATED PARTS BREAKDOWN

NO. 961 — WIZARD OF WOR UPRIGHT — PHOTOGRAPH

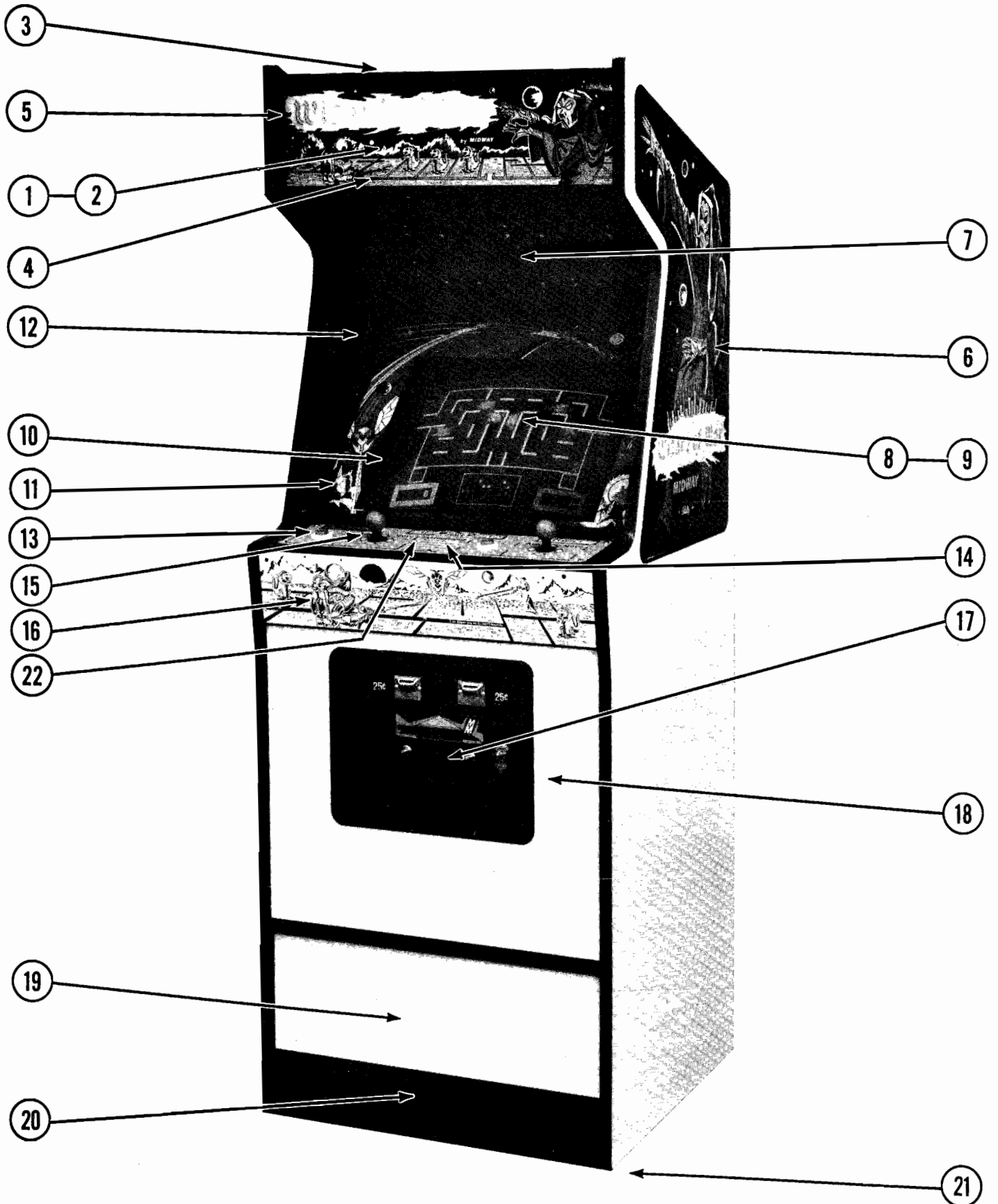

NO. 961 — WIZARD OF WOR UPRIGHT — PHOTOGRAPH
ORDER BY PART NUMBER ONLY

ITEM	PART NO.	DESCRIPTION
1	0961-00901-00XF	HEADER PLEXI - 22-7/8" x 7-3/8" x 3/16"
2	A961-00015-0000	FLUORESCENT LIGHT FIXTURE ASSY.
3	0961-00116-02XF	UPPER HEADER BRKT.
4	0961-00116-01XF	LOWER HEADER BRKT.
5	0017-00101-0117	#8 x 5/8 PHIL. TRUS. HD. SCR. (6 REQ'D.)
5	0537-00903-0054	GLASS CHANNEL - 6-5/8" LG.
6	0961-00907-0100	DECAL - RIGHT SIDE
6	0961-00907-0200	DECAL - LEFT SIDE (NOT SHOWN)
7	0017-00009-0393	BLACK SPEAKER GRILL (3 REQ'D.)
7	0017-00003-0259	6" x 9" SPEAKER 8 OHM, 7W (3 REQ'D.)
7	0017-00101-0639	#8-32 x 1 1/4 CARRIAGE BOLT (12 REQ'D.)
7	0017-00103-0061	#8-32 HEX NUT W/SEMS (12 REQ'D.)
8	0151-00075-0100	19" COLOR MONITOR
9	0961-00908-0000	PLEXI DIFFUSER - 14" x 18"
10	0961-00902-0000	T.V. BEZEL
10	A961-00026-0000	BEZEL MTG. BRKT. ASSY.- REAR (2 REQ'D.)
11	0961-00903-00XF	MAIN VIEWING GLASS - 22-13/16" x 17-7/8" x 16"
11	0961-00124-0000	VIEW GLASS SUPPORT BRKT. (2 REQ'D.)
12	0537-00903-0053	GLASS CHANNEL - 17 1/2" LG.
13	A855-00016-0000	PUSH BUTTON ASSY. (2 REQ'D.)
14	0017-00032-0051	SMALL RED SWITCH BUTTON (2 REQ'D.)
15	A963-00005-0000	CONTROL ASSY. (2 REQ'D.)
16	0961-00108-00XF	CONTROL PLATE
16	0017-00101-0118	#8-32 x 1-1/8 CARRIAGE BOLT (6 REQ'D.)
16	0017-00104-0030	#8 WASHER (6 REQ'D.)
16	0017-00103-0061	#8-32 HEX NUT W/SEMS (6 REQ'D.)
16	0017-00101-0065	#6 x 1/2 PHIL TRUS HD. SCREW (6 REQ'D.)
17	A090-00300-06BK	DOUBLE ENTRY COIN DOOR ASSY.
18	0090-0002-02BK	COIN DOOR FRAME
18	0017-00101-0121	#6-32 x 5/16 PHIL. TRS. HD. SCR. (3 REQ'D.) (MOUNTS COIN DOOR TO FRAME)
19	A961-00012-0000	SERVICE DOOR ASSY.
20	0935-00906-0200	KICK PLATE 22-7/8" LG.
21	0017-00102-0048	3/8-16 x 2" LEG LEVELERS (4 REQ'D.)
21	0017-00103-0026	3/8-16 LEG LEVELER HEX NUTS (4 REQ'D.)
22	0961-00900-0000	CONTROL SHELF OVERLAY

MIDWAY MFG. CO.
A BALLY COMPANY

NO. 961 — WIZARD OF WOR UPRIGHT — REAR ACCESS PICTURE

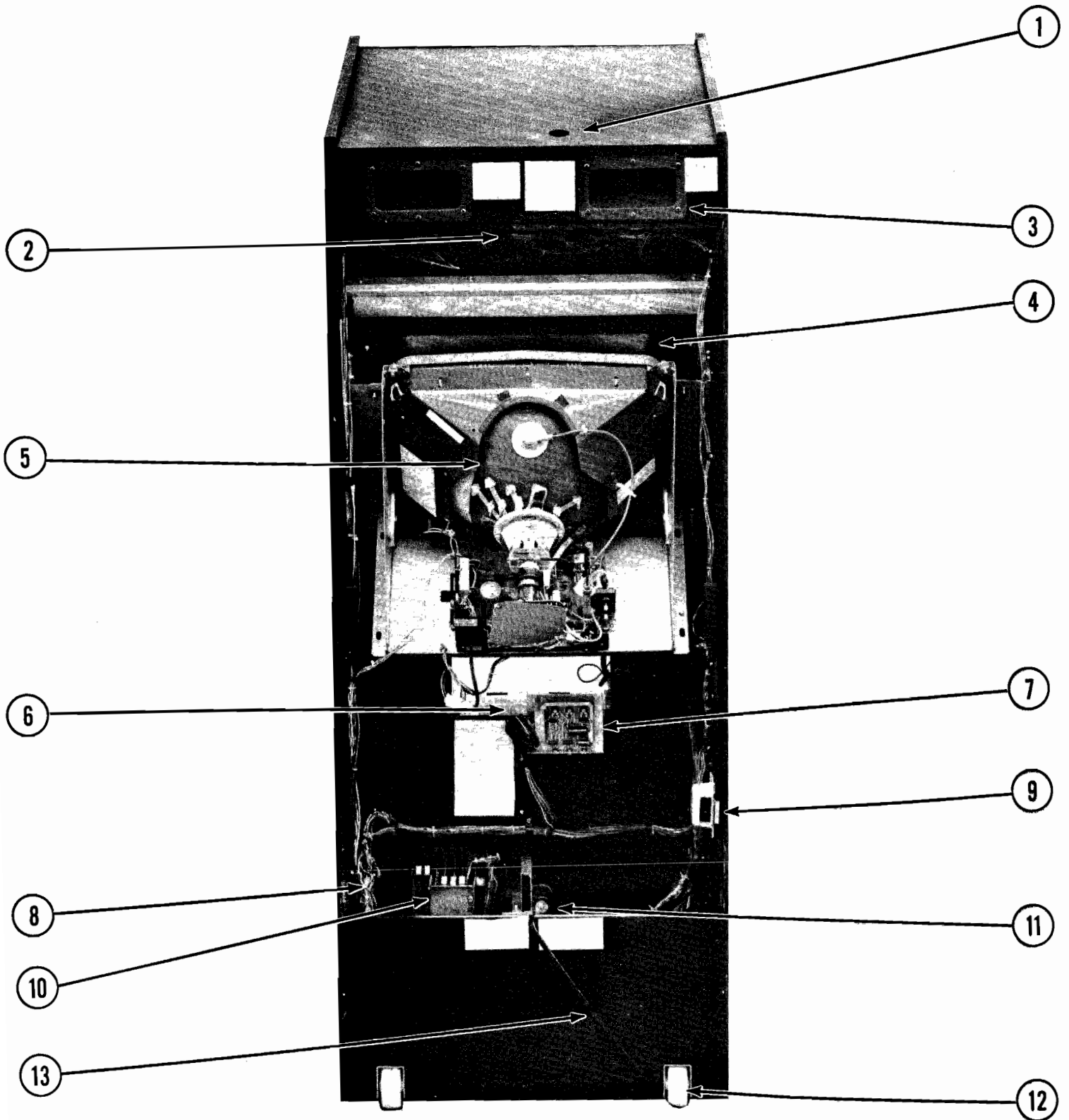

ORDER BY PART NUMBER ONLY

ITEM	PART NO.	DESCRIPTION
1	0017-00032-0083	ON/OFF SWITCH 120V., 6A.
	0567-00106-0100	ON/OFF SWITCH PLATE
2	0017-00003-0259	6''x 9'' SPEAKER 8 OHM, 7 W. (3 REQ'D.)
3	0894-00913-0000	RECESSED HAND LIFT (2 REQ'D.)
4	0017-00101-0117	#8 x 5/8 PHIL TRS. HD. SCR. (12 REQ'D.)
5	0961-00902-0000	T.V. BEZEL
5	0017-00003-0339	19'' DUAL SYNC COLOR MONITOR (ELECTROHOME) (OR)
5	0017-00003-0354	19'' DUAL SYNC COLOR MONITOR (WELLS-GARDNER)
	0961-00128-0000	MONITOR MTG RAIL (2 REQ'D.)
	0017-00102-0066	1/4-20 x 3/4 HEX BOLT (4 REQ'D.)
	0017-00104-0014	PERIPHERY WASHER (4 REQ'D.)
	0017-00103-0019	1/4-20 HEX LOCK NUT (2 REQ'D.)
	0017-00101-0769	#10 x 3/4 SLT. HEX. HD. SCR. (8 REQ'D.)
6	A961-00008-0000	COIN BOX COVER ASSY.
	0961-00110-0000	COIN BOX COVER
	A894-00024-0000	COIN BOX GUIDE BRKT. ASSY.
	0894-00121-0000	COIN BOX GUIDE BRKT.
	0017-00101-0628	#8-32 x 3/4 CARRIAGE BOLT (4 REQ'D.)
	0017-00104-0022	#8 WASHER (4 REQ'D.)
	0017-00103-0061	#8-32 HEX NUT W/SEMS (4 REQ'D.)
7	A961-00024-0000	AUDIO BOARD & BRKT. ASSY.
	A084-90907-A961	SOUND BRD. P.C. ASSY.
	0961-00127-0000	AUDIO AMP BRKT. & HEAT SINK
	0017-00007-0153	P.C. BRD. TO BRKT. SUPPORT (4 REQ'D.)
	0017-00101-0107	#6 x 5/16 SLT. HEX HD. SCR. (4 REQ'D.)
	0017-00042-0014	SNAP BUSHING (2 REQ'D.)
	0017-00042-0274	SHAFT FOR PIHER POT (3 REQ'D.)
8	A082-91363-B000	R-G-B INTERFACE P.C. BRD. ASSY.
	0017-00042-0014	SNAP BUSHING (4 REQ'D.)
	0017-00101-0107	#6 x 5/16 SLT. HEX HD. SCR. (4 REQ'D.)
9	A151-00027-0000	INTERLOCK SW & BRKT. ASSY.
10	A961-00019-0000	CARD RACK ASSY.
11	A082-90411-B000	UNIVERSAL POWER SUPPLY ASSY.
12	A961-00007-0000	CASTER ASSY. (2 REQ'D.)
	0961-00109-0000	WHEEL BRKT (2 REQ'D.)
	0017-00042-0255	WHEEL (PLASTIC) (2 REQ'D.)
	0894-00702-00XF	SHAFT (2 REQ'D.)
	0017-00100-0037	3/8 "E" - RING (2 REQ'D.)
13	A866-00049-0000	LINE CORD ASSY.
NOT SHOWN LIST	A097-00001-0000	LOCK ASSY. - REAR DOOR
	0618-00117-0000	VENT GRILL - REAR DOOR (4 REQ'D.)
	0762-00903-0000	PROTECTIVE BUBBLE - REAR DOOR
	0017-00101-0628	#8-32 x 3/4 CARRIAGE BOLT (4 REQ'D.)
	0017-00104-0022	#8 WASHER (4 REQ'D.) - 3/8 O.D.
	0017-00103-0061	#8-32 HEX NUT W/ SEMS (4 REQ'D.)
	0017-00009-0033	BASSICK CLAMP - CONTROL SHELF (2 REQ'D.)
	0603-00131-00XF	STRIKE - CONTROL SHELF (2 REQ'D.)
	0961-00113-0000	CONTROL SHELF SUPPORT - LEFT
	0961-00114-0000	CONTROL SHELF SUPPORT - RIGHT
	0961-00909-0000	SHELF SPACER (2 REQ'D.)
	0017-00004-0022	304 DYMAX STRAP
	A090-00082-0000	TEST SW. & BRKT. ASSY.

NO. 962 — WIZARD OF WOR COCKTAIL — PHOTOGRAPH
ORDER BY PART NUMBER ONLY

ITEM	PART NO.	DESCRIPTION
1	0962-00900-00XF	COVER GLASS - 32''x 22''x 1/4''
2	0775-00104-00XF	GLASS CLIPS (8 REQ'D.)
	0017-00101-0117	#8 x 5/8 PHIL. TRS. HD. SCR. (16 REQ'D.)
3	0017-00003-0339	19'' COLOR DUAL SYNC MONITOR - ELECTROHOME
4	0869-00907-0000	GREY PLEXI
5	0927-00903-0000	T.V. BEZEL
6	A962-00006-0000	CONTROL SHELF ASSY. - PLAYER #1
7	A962-00007-0000	CONTROL SHELF ASSY. - PLAYER #2
8	0017-00009-0393	SQUARE BLACK SPEAKER GRILL
	0017-00003-0161	4'' SQR. SPEAKER 8 OHM, 3 W. (2 REQ'D.)
9	A090-00300-06BK	DOUBLE ENTRY COIN DOOR ASSY.
10	0090-00002-02BK	LARGE COIN DOOR FRAME
	0017-00101-0121	#6-32 x 5/16 PHIL TRS. HD. SCR. (3 REQ'D.) (MOUNTS COIN DOOR TO FRAME)
11	0017-00102-0048	3/8-16 x 2'' LEG LEVELERS (4 REQ'D.)
	0017-00103-0026	3/8-16 LEG LEVELER HEX NUTS (4 REQ'D.)
	A927-00008-0000	NOT SHOWN LIST ON/OFF SWITCH ASSY.
	0017-00032-0071	INTERLOCK SWITCH
	0756-00900-0000	INTERLOCK SW. COVER
	G927-00005-0000	HIGH BASE - LEG KIT ASSY. - OPTIONAL (INCLUDES 4 LEGS & HARDWARE)
	0017-00004-0022	304 DYMAX STRAP
	A082-91363-B000	R-G-B INTERFACE P.C. BRD. ASSY.
	A961-00024-0000	AUDIO BRD. & BRKT. ASSY.
	A866-00036-0000	TEST SW. & BRKT. ASSY.
	A927-00019-0000	COIN BOX ASSY.
	A962-00004-0000	COIN BOX COVER ASSY.
	A962-00005-0000	COIN BOX SIDE CHANNEL ASSY. - SHORT
	0962-00101-0000	COIN BOX SIDE CHANNEL - SHORT
	0017-00101-0628	#8-32 x 3/4 CARRIAGE BOLT (4 REQ'D.)
	0017-00104-0022	#8 WASHER (4 REQ'D.)
	0017-00103-0061	#8-32 HEX NUT W/SEMS (4 REQ'D.)

MIDWAY MFG. CO.
A BALLY COMPANY

NO. 962 — WIZARD OF WOR COCKTAIL — INTERIOR ACCESS PHOTOGRAPH

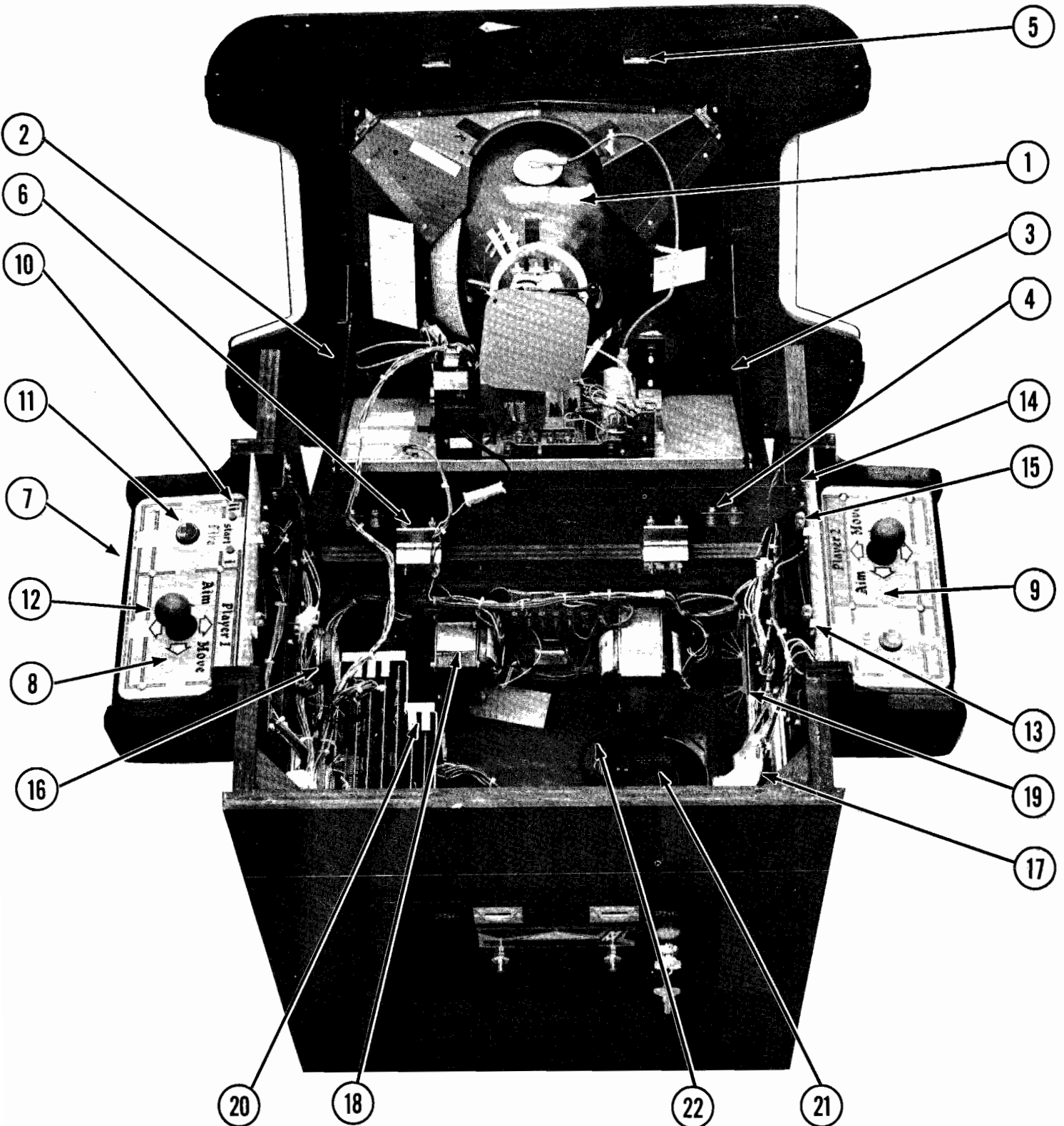

ORDER BY PART NUMBER ONLY

ITEM	PART NO.	DESCRIPTION
1	0017-00003-0339	19" COLOR DUAL SYNC MONITOR - ELECTROHOME (OR)
1	0017-00003-0354	19" COLOR DUAL SYNC MONITOR - WELLS-GARDNER
2	A869-00007-00XF	MONITOR SUPPORT ASSY. - L.H.
3	A869-00007-01XF	MONITOR SUPPORT ASSY. - R.H.
	0017-00101-0642	#8-32 x 1½ CARRIAGE BOLT (4 REQ'D.)
	0017-00104-0031	#8 FLAT WASHER (4 REQ'D.)
	0017-00103-0061	#8-32 HEX NUT W/SEMS (4 REQ'D.)
4	0927-00101-00XF	SUPPORT ANGLE (2 REQ'D.)
	0017-00101-0023	#8 x 3/8 PHL. TRS. HD. SCR. (10 REQ'D.)
5	0610-00132-00ZN	STRIKE (2 REQ'D.)
	0017-00009-0033	BASSICK CLAMP (2 REQ'D.) - NOT SEEN
	0017-00101-0027	#8 x 3/4 SLT. HEX HD. SCR. (8 REQ'D.)
6	0017-00009-0514	2½" HINGE (2 REQ'D.)
	0017-00101-0639	#8-32 x 1-1/4 CARRIAGE BOLT (8 REQ'D.)
	0017-00103-0061	#8-32 HEX NUT W/SEMS (8 REQ'D.)
7	0927-00109-00XF	CONTROL PANEL (2 REQ'D.)
8	0962-00901-0100	DECORATIVE CONTROL SHELF OVERLAY - PLAYER #1
9	0962-00901-0200	DECORATIVE CONTROL SHELF OVERLAY - PLAYER #2
	0017-00101-0620	#8-32 x 1/2 CARRIAGE BOLT (8 REQ'D.)
	0017-00104-0022	FLAT WASHER (8 REQ'D.)
	0017-00103-0061	#8-32 HEX NUT W/SEMS (8 REQ'D.)
	0017-00101-0341	#6 x 1/4 PHIL. TRS. HD. SCR. (10 REQ'D.)
10	0017-00032-0051	SMALL RED BUTTON SWITCH W/HARDWARE (2 REQ'D.)
11	A855-00016-0000	PUSH BUTTON ASSY. (2 REQ'D.)
12	A963-00005-0000	CONTROL ASSY. (2 REQ'D.)
13	0927-00904-0000	LIGHT SHIELD (2 REQ'D.)
14	0921-00105-00XF	PANEL SUPPORT BRKT. (4 REQ'D.)
	0017-00101-0025	#8 x 1/2 SLT. HEX HD. SCR. (12 REQ'D.)
15	0017-00003-0219	#194 LAMP 14V., .27 A. (4 REQ'D.)
	0017-00031-0044	WEDGE BASE LAMP SOCKET (4 REQ'D.)
	0017-00101-0555	#6-32 x 5/16 SLT. HEX HD. SCR. (4 REQ'D.)
16	0017-00003-0161	4" SQR. SPEAKER 8 OHM, 3W (2 REQ'D.)
	0017-00009-0393	SPEAKER GRILL (2 REQ'D.)
	0017-00101-0628	#8-32 x 3/4 CARRIAGE BOLT (8 REQ'D.)
	0017-00103-0061	#8-32 HEX NUT W/SEMS (8 REQ'D.)
17	0017-00003-0259	6" x 9" SPEAKER 8 OHM, 7W.
	0017-00009-0482	SPEAKER GRILL (2 REQ'D.)
	0017-00101-0639	#8-32 x 1-1/4 CARRIAGE BOLT (8 REQ'D.)
	0017-00103-0061	#8-32 HEX NUT W/SEMS (8 REQ'D.)
18	A962-00015-0000	TRANSFORMER BRD. ASSY.
	0962-00902-0000	TRANSFORMER FISHPAPER SHIELD
19	A082-90411-C000	UNIVERSAL POWER SUPPLY P.C. ASSY.
	0624-00902-0100	P.C. SUPPORT BRKT. - 12" LG.
	0624-00902-0300	P.C. SUPPORT BRKT. - 2½" LG. (2 REQ'D.)
	0624-00902-0500	P.C. SUPPORT BRKT. - 6½" LG.
	0017-00101-0017	#6 x 1/2 SLT. HEX HD. SCR. (10 REQ'D.)
	0017-00104-0031	STL. FLAT WASHER 5/8 DIA. (10 REQ'D.)

MIDWAY MFG. CO.

A BALLY COMPANY

ORDER BY PART NUMBER ONLY

ITEM	PART NO.	DESCRIPTION
20	A961-00019-0000	CARD RACK ASSY.
21	A775-00013-0000	FAN ASSEMBLY
	0151-00081-0000	4" MUFFIN FAN
	0775-00110-00XF	FAN PLATE
	0749-00106-00XF	FAN SCREEN
	0017-00101-0347	#6-32 x 1/2" R.H.M.S. (4 REQ'D.)
	0017-00104-0009	#6 EXT. WASHER (4 REQ'D.)
	0017-00103-0005	#6-32 HEX NUT (4 REQ'D.)
22	0017-00101-0026	#8 x 5/8 SLT. HEX HD. SCR. (4 REQ'D.)
	A866-00049-0000	LINE CORD ASSY.
	MT00-00091-0000	TRANSFORMER BOARD ASSY.
	MT00-00093-0000	TRANSFORMER 115/220V.
	0017-00003-0114	TRANSFORMER W/MAGNET
	0720-00001-0600	NOISE FILTER
	0017-00003-0103	6 POSITION FUSE CLIP ASSY.
	0017-00003-0004	FUSE - 1A., 250V. SLO-BLO
	0017-00003-0004	FUSE - 2A., 250V. SLO-BLO
	0017-00003-0261	FUSE - 1 1/2A., 250V. SLO-BLO
	0017-00003-0262	FUSE - 3A., 250V. SLO-BLO (3 REQ'D.)

NO. 963 — WIZARD OF WOR MINI — PHOTOGRAPH

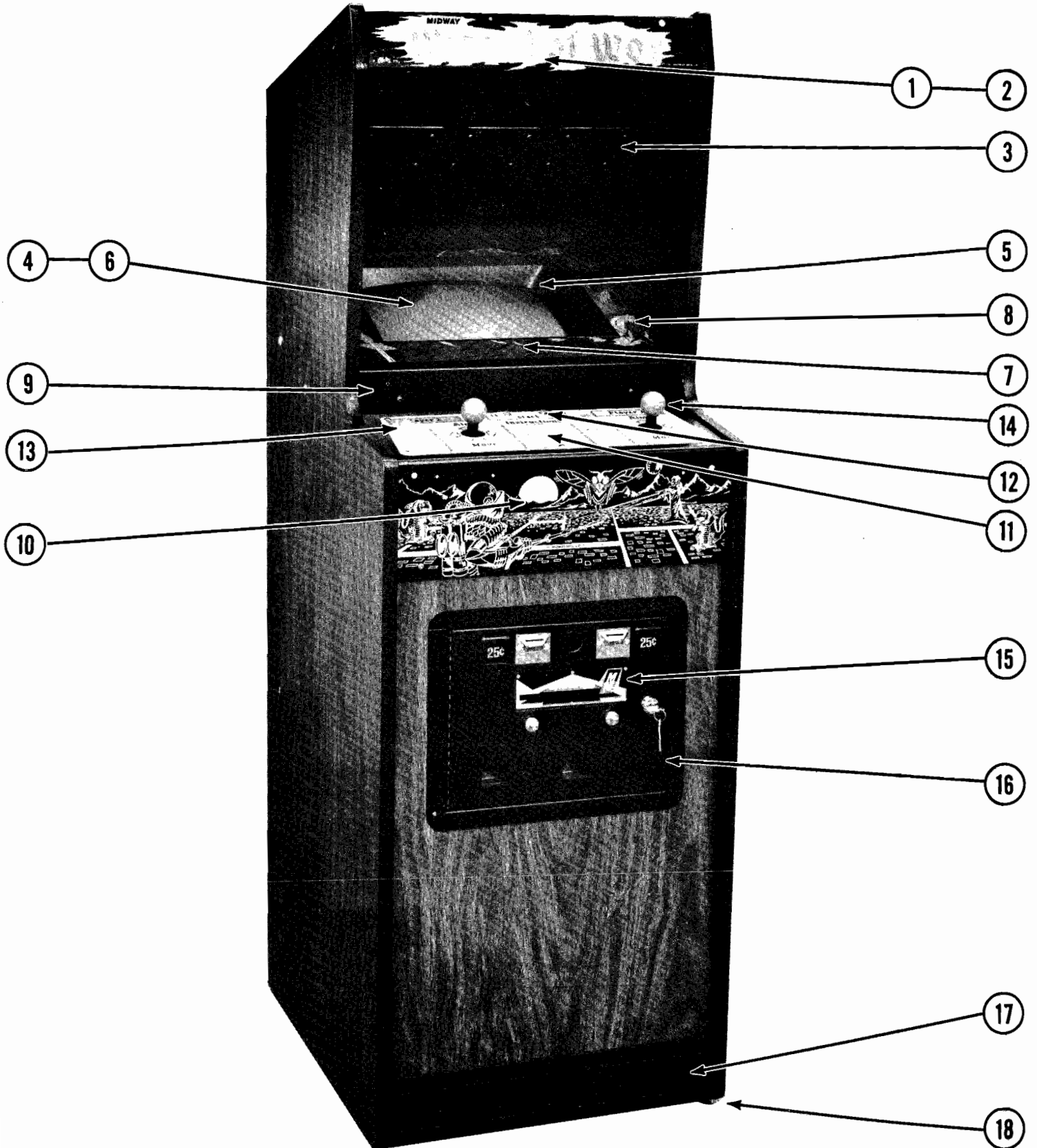

NO. 963 — WIZARD OF WOR MINI — PHOTOGRAPH
ORDER BY PART NUMBER ONLY

ITEM	PART NO.	DESCRIPTION
1	0963-00901-00XF 0017-00101-0117	DISPLAY PANEL #8 x 5/8 PHIL. TRS. HD. SCREW (8 REQ'D.)
2	A926-00010-0000 0017-00031-0030	INSERT DISPLAY ASSY. LIGHT SOCKET (5 REQ'D.)
3	0017-00003-0219 0017-00003-0161 0017-00009-0482 0017-00101-0127 0017-00103-0061	LAMP #194, 14V., .27A. WEDGE BASE (5 REQ'D.) 4" SQR. SPEAKER 8 OHM, 3W. (3 REQ'D.) SPEAKER GRILL (3 REQ'D.) #8-32 x 1 1/2" CARRIAGE BOLT (12 REQ'D.) #8-32 HEX NUT W/SEMS (12 REQ'D.)
4	0151-00075-0200	13" COLOR MONITOR
5	0963-00903-0000	T.V. BEZEL
6	0963-00904-0000	GREY PLEXI-GLASS 14" x 11-3/4" x 1/8"
7	0963-00902-00XF	MAIN DISPLAY GLASS 17-13/16" x 14-13/16" x 1/8"
8	0905-00903-0300	GLASS CHANNEL - 11-3/4" LG.
9	0963-00101-00XF 0017-00101-0789	GLASS CLAMPING PLATE #10-32 x 3/4 HEX BUTTON HD. SCR. (2 REQ'D.)
10	0963-00100-00XF	CONTROL PLATE
11	0963-00900-0000 0017-00101-0118 0017-00104-0022 0017-00103-0061 0017-00101-0065	SHELF OVERLAY #8-32 x 1-1/8 CARRIAGE BOLT (5 REQ'D.) FLAT WASHER (5 REQ'D.) #8-32 HEX NUT W/SEMS (5 REQ'D.) #6 x 1/2 PHIL. TRS. HD. SCR. (2 REQ'D.)
12	0017-00032-0051	SMALL RED SWITCH BUTTON W/HARDWARE (2 REQ'D.)
13	A855-00016-0000	PUSH BUTTON ASSY. (2 REQ'D.)
14	A963-00005-0000	CONTROL ASSY. (2 REQ'D.)
15	A090-00300-06BK	DOUBLE ENTRY COIN DOOR ASSY.
16	0090-00002-02BK 0017-00101-0121	LARGE DOOR FRAME #6-32 x 5/16 PHIL. TRS. HD. SCR. (3 REQ'D.) (MOUNTS COIN DOOR TO FRAME)
17	0935-00906-0400	KICK PLATE - 17-15/16" LG.
18	0017-00102-0048 0017-00103-0026	3/8-16 x 2" LEG LEVELERS (4 REQ'D.) 3/8-16 LEG LEVELER HEX NUTS (4 REQ'D.)

NO. 963 — WIZARD OF WOR MINI — REAR ACCESS PICTURE

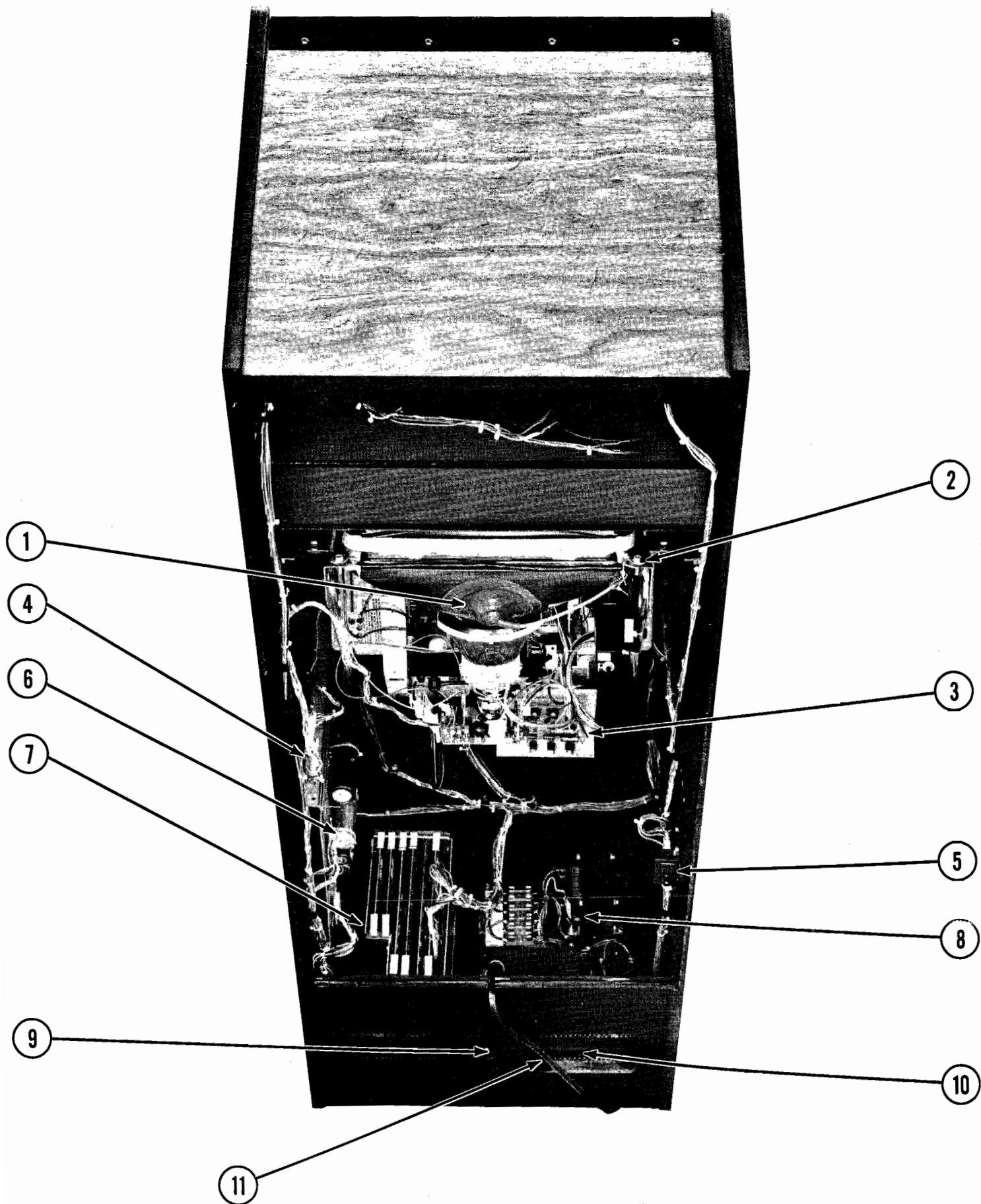

NO. 963 — WIZARD OF WOR MINI — REAR ACCESS PICTURE
ORDER BY PART NUMBER ONLY

ITEM	PART NO.	DESCRIPTION
1	0017-00003-0340	13" DUAL SYNC COLOR MONITOR - ELECTROHOME (OR)
1	0017-00003-0396	13" DUAL SYNC COLOR MONITOR - WELLS-GARDNER
	0017-00102-0066	1/4-20 x 3/4 UNSLOT. HEX BOLT (4 REQ'D.)
	0017-00104-0014	PERIPHERY WASHER .870 DIA. (4 REQ'D.)
2	A937-00012-00XF	MONITOR MTG. ANGLE ASSY. (2 REQ'D.)
	0017-00102-0019	1/4-10 x 1-1/2" RND. HD. BOLT (4 REQ'D.)
	0017-00104-0005	.489 DIA. SPLIT WASHER (4 REQ'D.)
	0017-00103-0018	1/4-20 HEX NUT (4 REQ'D.)
3	A961-00024-0000	AUDIO BOARD & BRKT. ASSY.
	A084-90707-A961	SOUND BOARD P.C. ASSY.
	0961-00127-0000	AUDIO AMP BRKT. & HEAT SINK
	0017-00007-0153	P.C. BRD. TO BRKT. SUPPORT (4 REQ'D.)
	0017-00101-0107	#6 x 5/16 SLT. HEX HD. SCR. (4 REQ'D.)
	0017-00042-0014	SNAP BUSHING (2 REQ'D.)
	0017-00042-0274	SHAFT FOR PIHER POT (3 REQ'D.)
4	A082-91363-B000	R-G-B INTERFACE P.C. BRD. ASSY.
	0017-00042-0014	SNAP BUSHING (4 REQ'D.)
	0017-00101-0107	#6 x 5/16 SLT. HEX HD. SCR. (4 REQ'D.)
5	A151-00027-0000	INTERLOCK S.W. & BRKT. ASSY.
6	A082-90411-C000	UNIVERSAL POWER SUPPLY P.C. ASSY.
	0624-00902-0100	P.C. BRKT. SUPPORT - 12" LG. (2 REQ'D.)
	0624-00902-0300	P.C. BRKT. SUPPORT - 2 1/2" LG. (2 REQ'D.)
	0017-00101-0027	#8 x 3/4 SLT. HEX HD. SCR. (10 REQ'D.)
	0017-00104-0037	#8 STL. WASHER - .750 DIA. (10 REQ'D.)
7	A961-00019-0000	CARD RACK ASSY.
8	A963-00014-0000	TRANSFORMER BOARD ASSY. (SEE U.R. UTILITY SHELF ASSY.)
	0963-00905-0000	FISHPAPER SHIELD
9	0017-00032-0083	ON/OFF SWITCH 120V., 6A.
	0567-00106-0100	ON/OFF SW. MTG. PLATE
10	0017-00009-0490	VENT GRILL - 5-5/8 SQR. (2 REQ'D.-DOOR, 2 REQ'D.-CABINET BACK)
11	A866-00049-0000	LINE (POWER) CORD ASSY.
	0017-00009-0033	NOT SHOWN LIST BASSICK CLAMP (3 REQ'D.)
	0961-00115-00XF	STRIKE (2 REQ'D.)
	0963-00102-00XF	CENTER STRIKE
	0017-00101-0028	#8 x 3/4 SLT. HEX HD. SCR. (12 REQ'D.)
	A151-00029-0000	LOCK ASSY - BACK DOOR
	0017-00004-0022	304 DYMAX STRAP
	A905-00028-0000	CASH BOX ASSY. W/HANDLE
	A961-00008-0000	CASH BOX COVER ASSY.
	A894-00024-0000	CASH BOX SIDE CHANNEL ASSY.
	0894-00121-0000	CASH BOX SIDE CHANNEL - LONG
	0017-00101-0628	#8-32 x 3/4 CARRIAGE BOLT (4 REQ'D.)
	0017-00104-0022	FLAT WASHER (4 REQ'D.)
	0017-00103-0061	#8-32 HEX NUT W/SEMS (4 REQ'D.)
	0961-00113-0000	CONTROL SHELF SUPPORT - LEFT
	0961-00114-0000	CONTROL SHELF SUPPORT - RIGHT

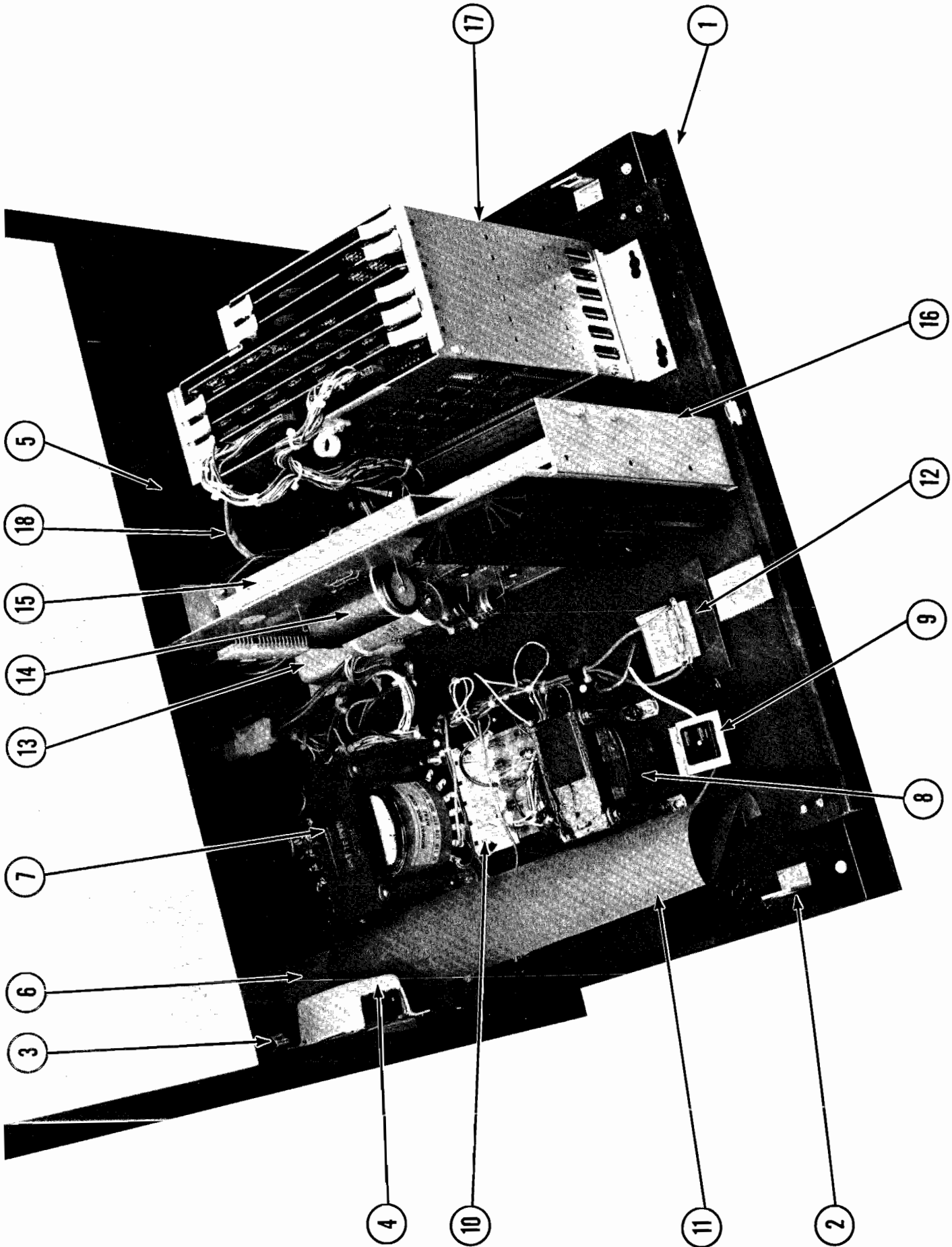

NO. 961 — WIZARD OF WOR UPRIGHT — UTILITY SHELF & SERVICE DOOR ASSYS.

ORDER BY PART NUMBER ONLY

ITEM	PART NO.	DESCRIPTION
1	0961-00904-0100 0017-00009-0512 0017-00101-0027	DOOR PULL - 22-7/8" LG. DOOR HINGE (2 REQ'D.) #8 x 3/4 SLT. HEX HD. SCR. (12 REQ'D.)
2	0961-00115-00XF	STRIKE (2 REQ'D.)
3	0017-00009-0033 0017-00101-0028	BASSICK CLAMP (2 REQ'D.) #8 x 3/4 SLT. HEX HD. SCR. (4 REQ'D.-CLAMP, 4 REQ'D.-STRIKE)
4	A151-00027-0000 0756-00900-0000	INTERLOCK SWITCH & BRKT. ASSY. INTERLOCK SW. COVER
5	0961-00119-0100	UTILITY SHELF RAIL - RIGHT
6	0961-00119-0200 0961-00117-0000 0961-00120-0000 0961-00121-0000 0017-00101-0027	UTILITY SHELF RAIL - LEFT UTILITY SHELF STOP BRKT. CABINET STOP BRKT. SHELF STOP BRKT. #8 x 3/4 SLT. HEX HD. SCR. (46 REQ'D.)
7	MT00-00087-0000	POWER TRANSFORMER 120/240V.
8	MT00-00092-0000 0017-00101-0628 0017-00103-0061 0017-00101-0025	TRANSFORMER #8-32 x 3/4 CARRIAGE BOLT (4 REQ'D.) #8-32 HEX NUT W/SEMS (4 REQ'D.) #8 x 1/2 SLT. HEX HD. SCR. (4 REQ'D.)
9	A151-00079-0000	115V. CONVENIENCE OUTLET ASSY.
10	0720-00001-0500 0017-00003-0001 0017-00003-0261 0017-00003-0262 0017-00003-0004	5 POSITION FUSE CLIP ASSY. FUSE 1A. 250V. FUSE 1.5A. 250V. SLO-BLO FUSE 3A. 250V. SLO-BLO (2 REQ'D.) FUSE 2A. 250V. SLO-BLO
11	0961-00905-0000	FISHPAPER SHIELD
12	0720-00001-0100 0017-00003-0004 0961-00906-0000	1 POSITION FUSE CLIP ASSY. FUSE 2A. 250V. SLO-BLO FISHPAPER SHIELD
13	0017-00003-0114 0756-00900-0000	NOISE FILTER COVER
14	A082-90411-B000	UNIVERSAL POWER SUPPLY ASSY.
15	A961-00027-0000	TOP BRKT. ASSY.
16	A961-00049-0000 0017-00101-0015	MTG. FRAME & SUPPORT BRKT. MTG. ASSY. #6 x 1/2 SLT. HEX HD. SCR. (11 REQ'D.)
17	A961-00019-0000	CARD RACK ASSY. - (SEE SEPARATE ILLUSTRATION)
18	3000-04271-0000 A866-00049-0000	YELLOW INSULATED GROUND STRAP LINE (POWER) CORD ASSY. - NOT SHOWN

MIDWAY MFG. CO.

A BALLY COMPANY

WIZARD OF WOR — CONTROL ASSEMBLY

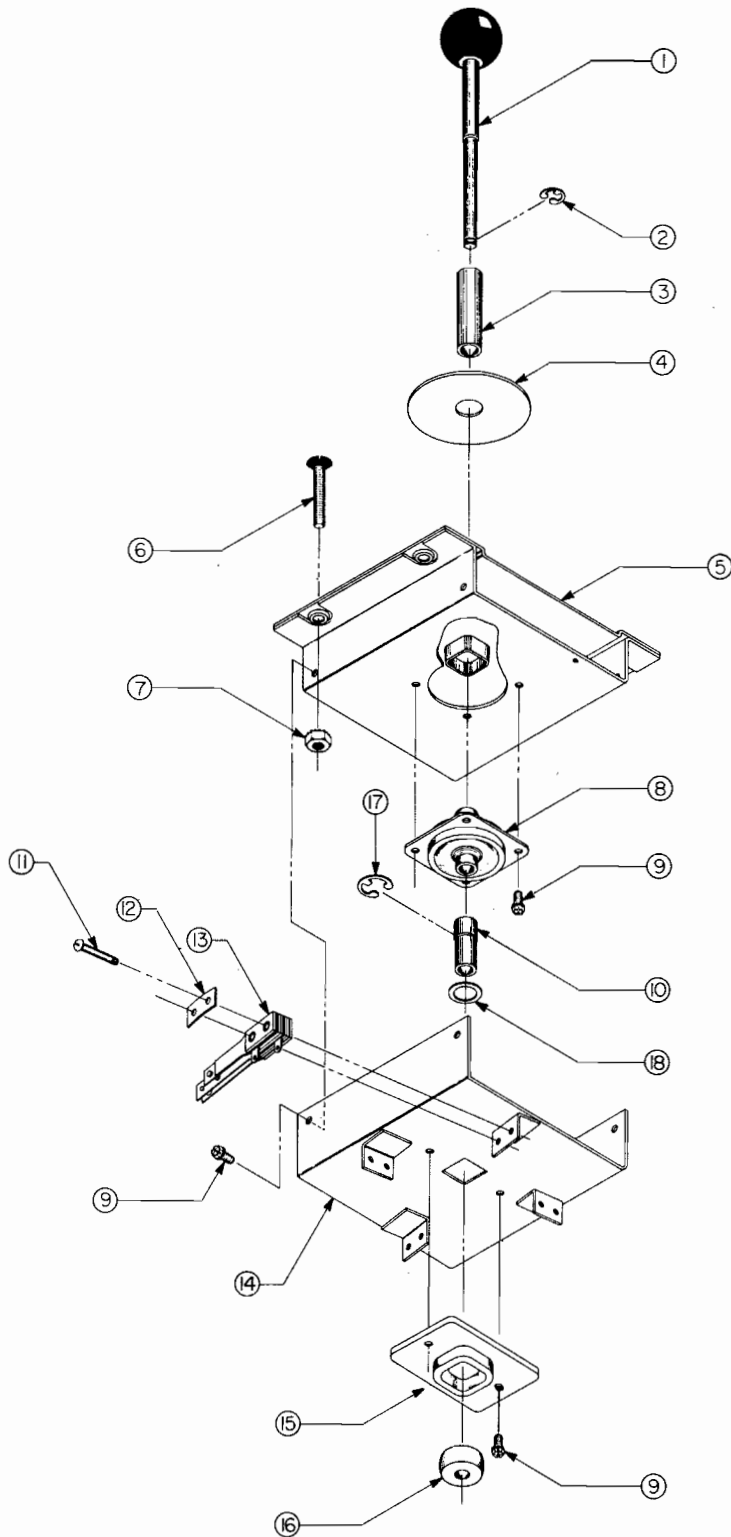

WIZARD OF WOR — CONTROL ASSEMBLY

ORDER BY PART NUMBER ONLY

ITEM	PART NO.	DESCRIPTION
1	A932-00022-0000	BALL & SHAFT ASSEMBLY
2	0017-00100-0025	1/4" E-RING
3	0921-00702-0000	STOP SPACER
4	0921-00902-0000	SLIDE PLATE
5	A932-00011-00XF	SPOT WELD ASSY.
6	0017-00101-0713	#8-32 x 1" SLT. FLAT HD. SCREW (4 REQ'D.)
7	0017-00103-0061	#8-32 HEX NUT W/SEMS (4 REQ'D.)
8	0932-00902-0000	GROMMET
9	0017-00101-0598	#8-32 x 5/16 SLT. HEX HD. M.S. (10 REQ'D.)
10	0921-00701-0000	SLEEVE
11	0017-00101-0528	#5-40 x 3/4 SLT. RND. HD. SCR. (8 REQ'D.)
12	0020-00202-0000	SWITCH PLATE (4 REQ'D.)
13	A963-00013-0000	SWITCH ASSEMBLY (4 REQ'D.)
14	A963-00012-00XF	STOP PLATE & SWITCH BRKT. ASSY.
15	0932-00905-0000	WEAR PLATE
16	0921-00700-0000	ACTUATOR
17	0017-00100-0115	7/16" E-RING
18	0017-00104-0111	NYLON FLAT WASHER

WIZARD OF WOR — ALL VERSIONS — COMMERCIAL CARD RACK ASSY.

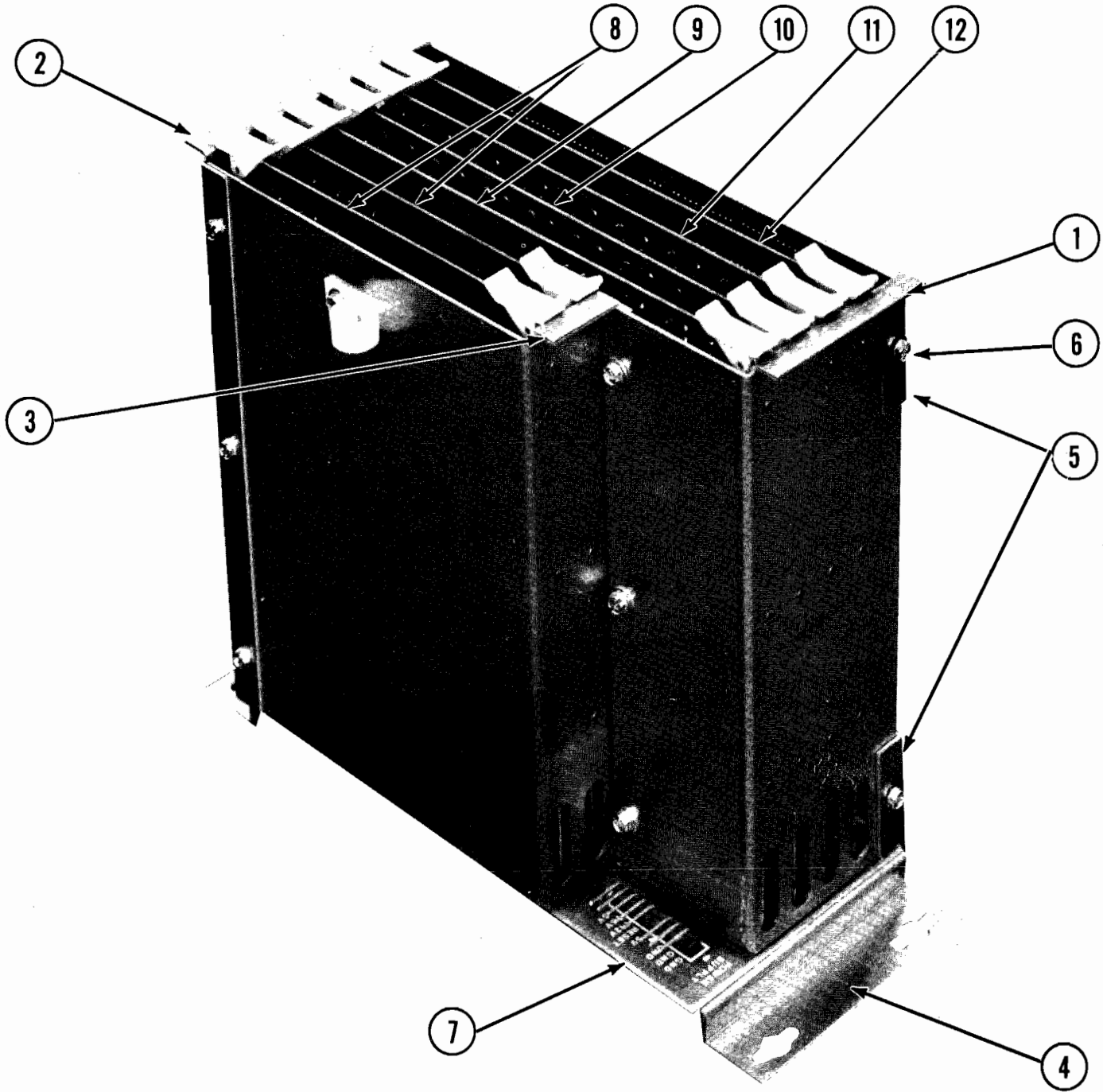

WIZARD OF WOR — COMMERCIAL CARD RACK ASSEMBLY
ORDER BY PART NUMBER ONLY

ITEM	PART NO.	DESCRIPTION
1	A789-00003-0100	P.C. RACK ASSY. - RIGHT
2	A789-00004-0100	P.C. RACK ASSY. - LEFT
3	A789-00005-0000	P.C. RACK ASSY. - BASE
4	0789-00100-0000	MTG. BRKT. SUPPORT (2 REQ'D.)
5	0789-00106-0000	RACK STRAP (2 REQ'D.)
6	0017-00101-0099	#6 x 1/4 SLT. HEX HD. SCREW (11 REQ'D.)
	0017-00104-0019	#6 FLAT WASHER (3 REQ'D.)
7	A082-90006-B000	BACK PANEL P.C. ASSY. (MOTHER BOARD)
8	A082-91356-C000	RAM BOARD ASSY.
9	A082-91354-F000	CPU BOARD ASSY.
10	A082-91355-C000	PATTERN TRANSFER BOARD ASSY.
11	A082-91397-A000	MEMORY BOARD ASSY.
12	A084-90708-A961	GAME LOGIC BOARD ASSY.
	0017-00007-0153	P.C. BOARD SUPPORT (2 REQ'D.) (NOT SHOWN)

MIDWAY MFG. CO.
 A BALLY COMPANY

WIZARD OF WOR — PUSH BUTTON ASSEMBLY

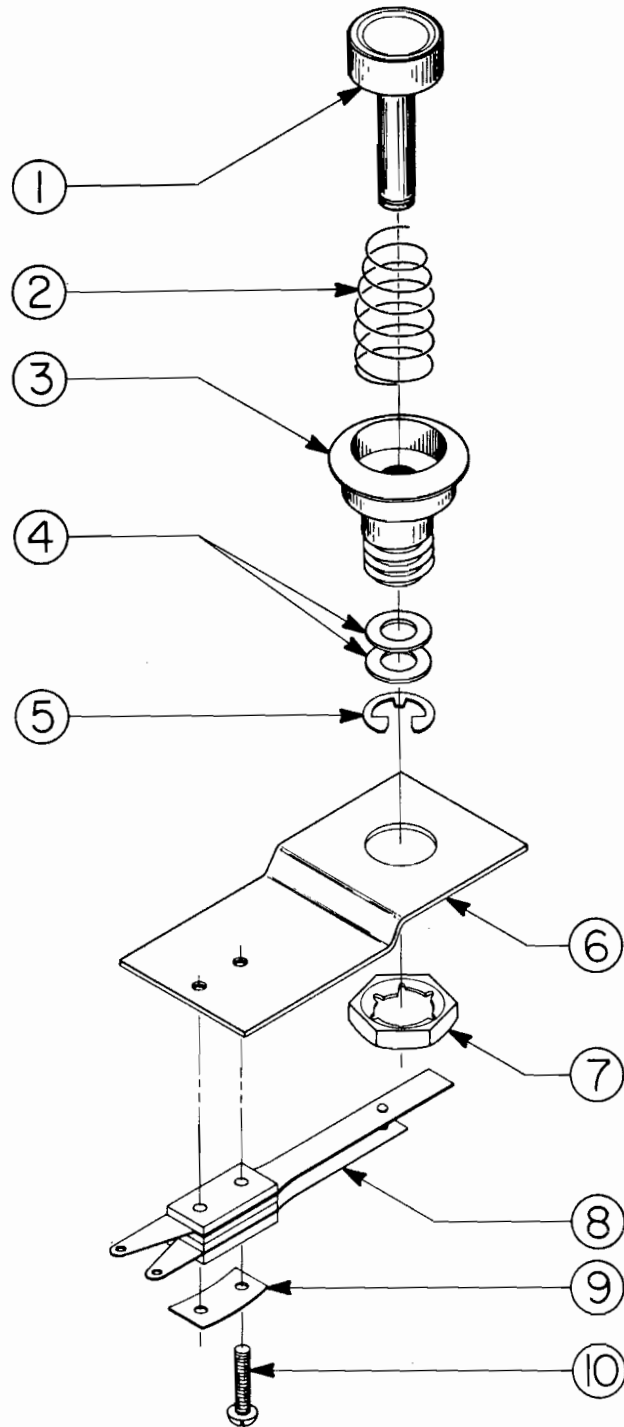

WIZARD OF WOR – PUSH BUTTON ASSEMBLY
ORDER BY PART NUMBER ONLY

ITEM	PART NO.	DESCRIPTION
1	0017-00009-B384	BUTTON - RED
2	0010-00242-0000	SPRING
3	0017-00009-0376	BUTTON HOUSING
4	0017-00104-0028	FLAT WASHER (2 REQ'D.)
5	0017-00100-0025	1/4" E-RING
6	A855-00016-0000	PUSH BUTTON ASSY. (FIRST 5 ITEMS)
6	A927-00011-0000	MOUNTING BRKT. ASSY. - (COCKTAIL)
6	0586-00107-0000	MOUNTING BRKT. - (UPRIGHT & MINI ONLY)
7	0017-00103-0054	PAL NUT
8	A961-00052-0000	SWITCH ASSEMBLY
9	0020-00202-0000	SWITCH PLATE
10	0017-00101-0526	#5-40 x 9/16 PHIL. HD. M.S. (2 REQ'D.)

NO. 961 — WIZARD OF WOR — FLUORESCENT FIXTURE ASSEMBLY

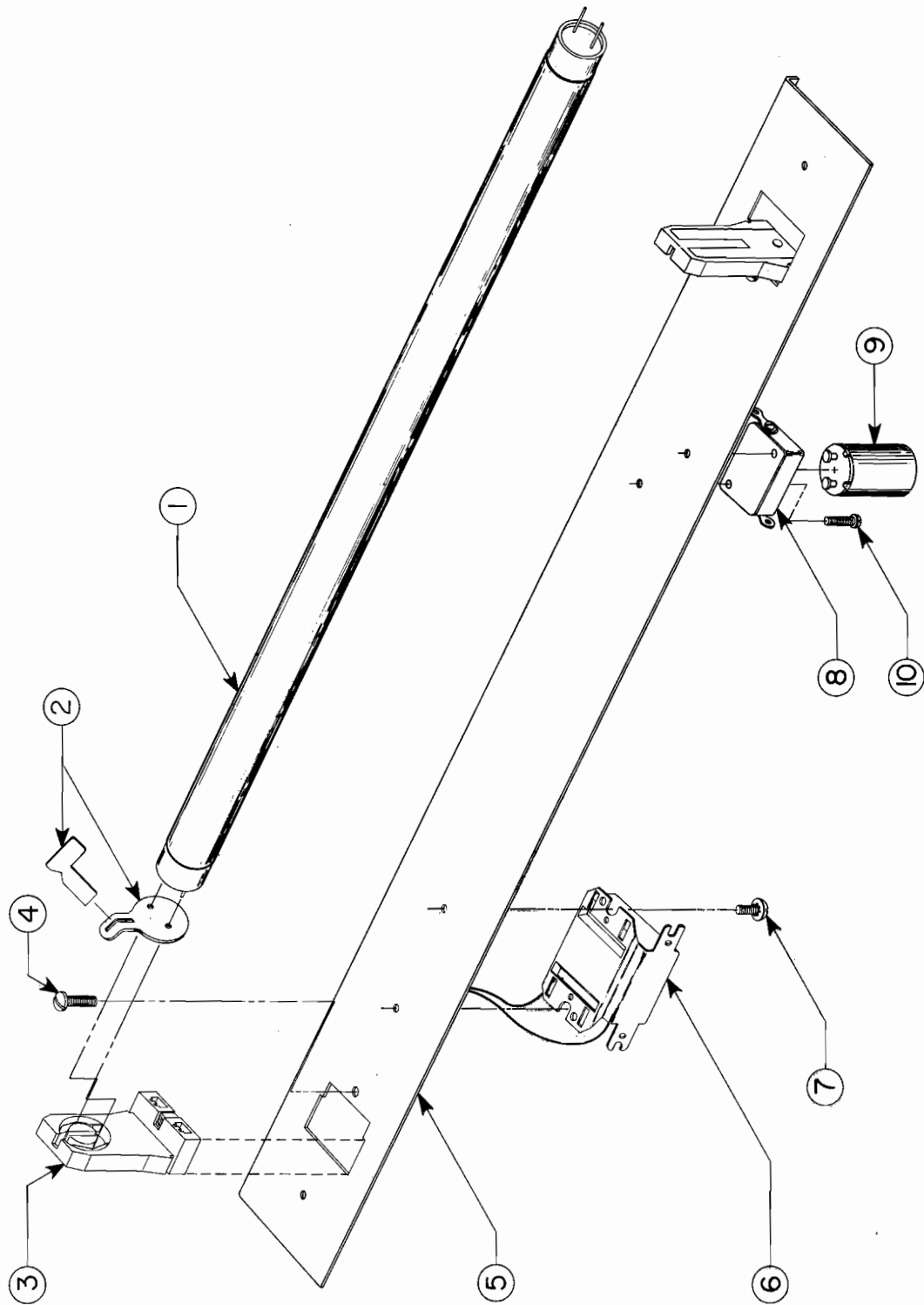

NO. 961 — WIZARD OF WOR — FLUORESCENT FIXTURE ASSEMBLY

ORDER BY PART NUMBER ONLY

ITEM	PART NO.	DESCRIPTION
1	0017-00003-0043	18'' COOL WHITE FLUORESCENT LAMP
2	0017-00021-0005	FLUORESCENT LOCKS (2 REQ'D.)
3	0017-00031-0036	FLUORESCENT SOCKET (2 REQ'D.)
4	0017-00101-0573	#6-32 x 1/2 SLT. RND. HD. M.S. (2 REQ'D.)
5	0961-00118-0000	FLUORESCENT BRKT.
6	0017-00003-0026	BALLAST
7	0017-00101-0598	#8-32 x 5/16 HEX HD. S.T.M.S. (2 REQ'D.)
8	0017-00101-0079	STARTER HOLDER
9	0017-00003-0019	STARTER
10	0017-00101-0529	#5-40 x 7/8 SLT. RND. HD. M.S. (2 REQ'D.)

MIDWAY MFG. CO.

A BALLY COMPANY

WIZARD OF WOR — ALL VERSIONS — FRONT DOOR ASSY.

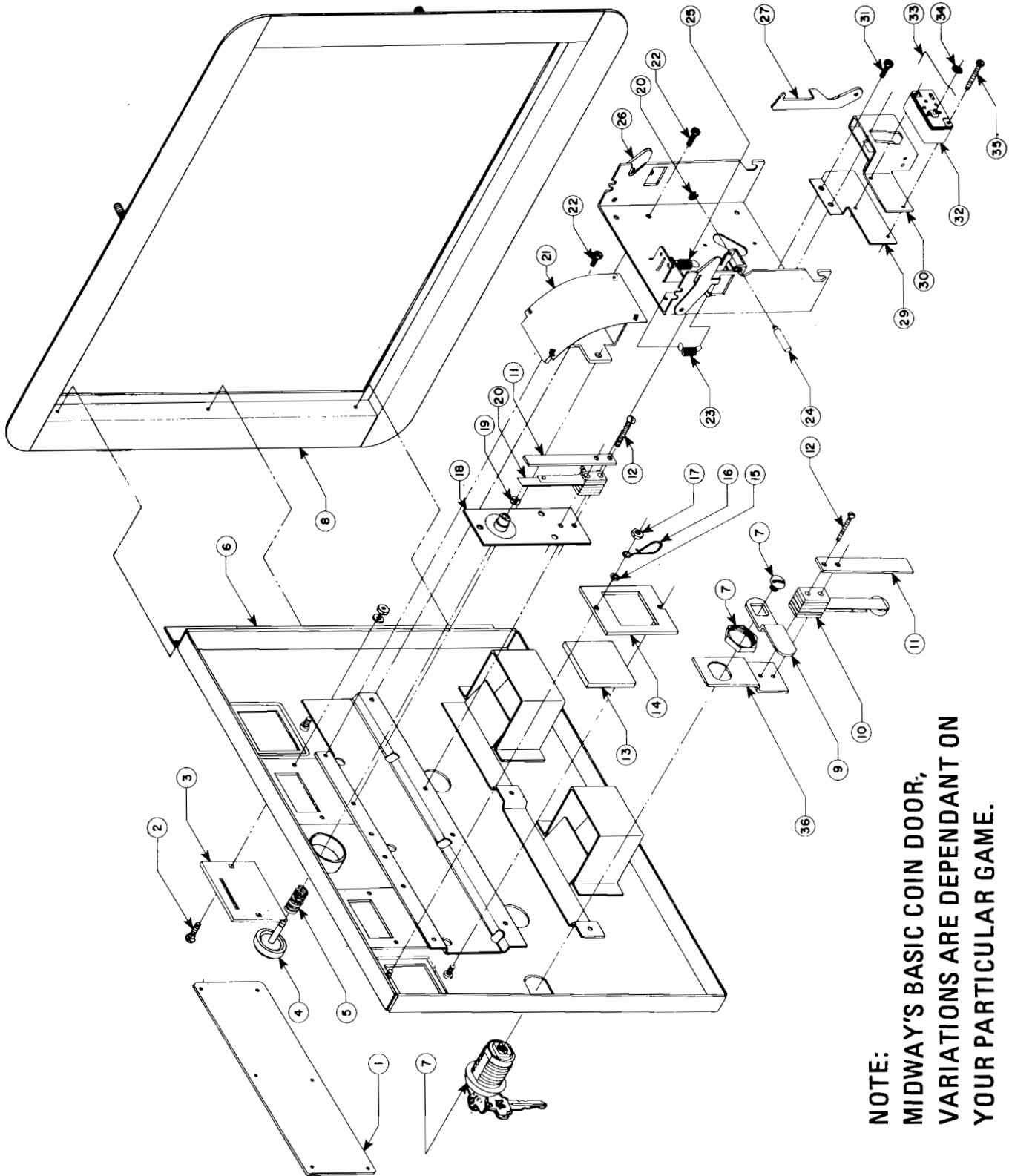

**NOTE:
MIDWAY'S BASIC COIN DOOR,
VARIATIONS ARE DEPENDANT ON
YOUR PARTICULAR GAME.**

WIZARD OF WOR — ALL VERSIONS — FRONT DOOR ASSEMBLY

ORDER BY PART NUMBER ONLY

ITEM	PART NO.	DESCRIPTION
1	0090-00902-0000	DRESS PLATE
	0090-00902-0100	DRESS PLATE W/O BUTTON TO START GAME
2	0017-00101-0552	#6-32 x 1/4 CARRIAGE BOLT (2)
3	0090-00117-03XF	COIN ENTRY PLATE (25¢)
4	0090-00906-0000	PLASTIC START BUTTON
5	0010-00007-0000	COMPRESSION SPRING
6	A090-00020-2003	DOOR ASSY. DOUBLE ENTRY
7	0017-00005-0050	DOOR LOCK & KEY WITH SCREW & NUT
8	0090-00002-02BK	DOUBLE DOOR FRAME
9	0017-00005-0041	421 N.S. CAM
10	0090-00901-0000	DOOR SWITCH
	0090-00126-01XF	SWITCH BACKUP PLATE
12	0017-00101-0528	#5-40 x 3/4" LNG. M.S.
13	0090-00903-9500	25¢ WINDOW
14	0090-00143-00XF	COIN PLEX RETAINER
15	0017-00104-0002	SPLIT LOCK WASHER
16	0017-00007-0019	KEY HOOK
17	0017-00103-0087	#6-32 HEX NUT
18	0090-00010-0000	SW. PLATE & OILLITE ASSY.
19	0017-00100-0018	"E" RING
20	0090-00131-0000	SWITCH
21	A090-00027-0000	TOP & BTM. COIN CHUTE W/BRKT. ASSY.
22	0017-00101-0123	#8 x 1/4 SCREW
23	0010-00181-0100	SPRING
24	0090-00129-00XF	PIVOT POST
25	0010-00134-0000	SPRING
26	A090-00085-0000	ACCEPTOR FRAME ASSY.
27	0093-00155-00XF	REJECTOR LEVER
28	0017-00100-0012	"E" RING
29	0090-00162-00XF	COIN SWITCH MTG. BRKT.- SMALL
29	0090-00163-00XF	COIN SWITCH MTG. BRKT.- LARGE
30	0017-00005-0203	COIN SWITCH CHUTE - SMALL
30	0017-00005-0204	COIN SWITCH CHUTE - LARGE
31	0017-00101-0124	#6 x 1/4 SCREW
32	0017-00005-0195	COIN SWITCH
33	0010-00599-0000	COIN SWITCH WIRE
34	0017-00007-0132	PUSH-ON RING (BLK.)
35	0017-00101-0698	#4-40 x 3/4 SCREW (2 REQ'D.)
36	0090-00128-00XF	SWITCH BRKT.- DOOR TILT
	A090-00061-0000	ANTI-STRING DEVICE ASSY.
	A090-00064-0000	ANTI-PENNY DEVICE ASSY.

MIDWAY MFG. CO.

A BALLY COMPANY

V. TECHNICAL TROUBLE SHOOTING



CARD RACK BOARD TEST

RAM TEST

1. Remove Game Card PC A084-90708-A902.
2. Remove Pattern Card PC A084-91355-C000.
3. Remove Ram Card in position J-2 PC A082-91356-B000.
4. The Ram Card in position J-1 must remain and be a known good card.
5. Do not remove the CPU Card A082-91354-E000.
6. Insert the Card Rack Board Tester PC A080-91517-A000 into position J-4.
7. Insert the Ram Test Card into position J-6 PC A080-91516-A000.
8. Insert the bad Ram Card into 18 pin connector of Ram Card Tester.
9. Connect video cable to connector J-2 of Card Rack Board Tester pins 11 and 12.
10. Move black slide switch on Card Rack Board Tester into position #1.
11. The dip switch settings must be as follows: 1 - 3 - 5 - 7 OFF and 2 - 4 - 6 - 8 ON.
12. Press Red reset button (S-1) on Ram Test Card to clear system.
13. A bad Ram location will flash on video screen and on flashing Rams indicate all Rams are good.
14. Move black slide switch on Card Rack Board Tester to position #2.
15. Clear system again by pressing Red reset button on Ram Test Card S1.
16. If the Rainbow test shows Garbage, check the video output. (74LS166)
17. When Rams are all good and Rainbow pattern is clear this indicates a good Ram Card.
18. Proceed to Pattern Card Test.

PATTERN BOARD TEST

1. Remove Ram Test Card PC A080-91516-A000.
2. Remove Card Rack Board Tester Card from J-4 and insert it into J-6 A080-91517-A000.
3. Remove the two Ram Test Proms located at X-4 and X-5 of Card Rack Board Tester.
4. Insert two Pattern Test Proms at location X-4 and X-5.
5. Connect video cable to connector J-2 of Card Rack Board Tester pins 11 and 12.
6. Insert bad Pattern Card into 50 pin connector of Card Rack Board Tester.
7. Press Red reset button to clear system.
8. A bad Pattern Card will display area of trouble on video screen.
9. A good Pattern Card will display the words ("LOOKS GOOD").
10. Connectors J-1 and J-5 are not used at this time.
11. The Dip Switch is for future use.

NOTE: When chip U-2 (74S138) is removed the Card Rack Board Tester Card PC A080-91517-A000 can be used as an extender card for powering up the CPU, Pattern and Game Cards.

The black slide switch should be in position #1 when X4 & X5 Roms are in proper location.

For proper Pattern Test, two Ram Cards must be used. PC A082-91356-B000.

MIDWAY'S CARD RACK SYSTEM

PATTERN BOARD TEST

<u>FATAL ERRORS</u>	<u>LOCATION</u>
DATA LATCHES	U19 & U10 74LS175
FLUSH DATA BIT 08	U21 PIN 10 74174
DIRECTION DATA BIT 01	U21 PIN 2 74174
AREA AND LINEAR HIGH 2 BITS	LINEAR: U7 PIN 3 & 13 U8 PIN 10 & 13 AREA: U9 PIN 3 & 13 U8 PIN 11 & 14
TRI - STATE BUFFERS	U20 & U11 74LS367
CONTROL LOGIC (CLOCK)	U5 - 74LS161 U6 - 74LS04 U12 - 74LS00

PATTERN BOARD TEST

1. U21 74LS174 IS THE STATUS LATCH.

PIN 2 DIRECTION

PIN 5 EXPAND

PIN 7 CONSTANT

PIN 10 FLUSH

PIN 12 FLIP

PIN 15 FLOP

THE U21 STATUS CHIP WILL CONTROL THE SHIFTING OF DATA IN A CERTAIN DIRECTION, MAKING A LARGER OBJECT, MOVING THE SAME SIZE OBJECT, TURNING OR ROTATING THE OBJECT, ETC.

2. THE HEX. CODE 08 AND 01 IS CONVERTED INTO A BINARY CODE:

08 = 00001000

01 = 00000001

3. FLUSH SETS MEMORY TO A FIX COLOR.

PATTERN BOARD THEORY OF OPERATION

MIDWAY'S CARD RACK SYSTEM

This explanation of the theory of operation is intended to be very basic and not a chip-by-chip or signal-by-signal explanation. There are some complicated features of this assembly that would take too much room to explain nor would it serve any useful purpose for the service technician.

The function of this board is to move blocks of data from one memory location to another at a fast rate. In the Card Rack System this translates into the ability to transfer a pattern on the screen (or from ROM) to another location on the screen.

Parameters are passed to the Pattern Board by a series of output instructions to ports 78 through 7E. IC's U1, U2, U4 and portions of U3, U6 and U14 perform the port decoding.

The following is a sequence of events in a typical operation of transferring a color encoded pattern from ROM to screen RAM.

The mode control byte is loaded into U21 by an output instruction to port 7A. Here the various modes of operation are selected.

The sixteen-bit linear address (which is usually the source address) is loaded into U34, U25, U16 and U7. The low-order eight bits are loaded into U34 and U25 by an output instruction to port 78. The high-order eight bits are loaded into U16 and U7 by an output instruction to port 79.

The sixteen-bit area address (which is usually the destination) is loaded into U39, U30, U18 and U9. The low-order eight bits are loaded into U39 and U30 with an output instruction to port 7B. The high-order eight bits are loaded into U18 and U9 with an output instruction to port 7C.

A line offset value is loaded into U39 and U30 with an output instruction to port 7B.

The width of the pattern is loaded into U41 and U32 with an output instruction to port 7D. The height of the pattern is loaded into U40 and U31 with an output to port 7E. This instruction also starts the following sequence to perform the actual pattern transfer.

The output to port 7E presets one-half of U13 sending the signal $\overline{\text{BUSREQ}}$ low. The Z-80 (located on the CPU board) responds by tri-stating its address, data and control signals and then asserting $\overline{\text{BUSACK}}$ low.

When $\overline{\text{BUSACK}}$ goes low, the control signal buffers for $\overline{\text{RD}}$, $\overline{\text{WR}}$, $\overline{\text{MREQ}}$ and $\overline{\text{IORQ}}$ are enabled placing the control signals on the bus; the tri-state address multiplexers U35, U26, U17, U8 and data buffers U20 and U11 are enabled placing their signals on the bus; and the master clock generator U5 starts counting. During the time that this Pattern Board has control of the bus, the signals appear identical to those created by the Z-80.

The first cycle is a read from the address contained by the linear address counters with the data going into the data hold registers U19 and U10.

The next cycle is a write cycle to the address contained in the area address counters. The data is placed on the data bus by the tri-state buffers U20 and U11.

This typical read-write cycle continues until the width counters U42 and U33 count down to zero. This completes one horizontal line of data transfer.

To prepare for the next horizontal line of data transfer two things must occur. First, the width count contained in U41 and U32 is loaded into U42 and U33. Simultaneously the height count contained in U40 and U33 is decremented. Second, the distance to the starting point on the next line, contained in U39 and U30 is added (through U38 and U29) to the present count contained in U37 and U28 and then loaded into counters U36 and U27.

These line transfers count until the height counters U40 and U31 reach zero.

At this time, $\overline{\text{BUSREQ}}$ is taken high disabling the clock generator U5 from any further activity. Also all data, address and control lines are tri-stated off of the bus returning control to the Z-80. The Z-80 responds by taking $\overline{\text{BUSACK}}$ high and continuing with its normal operation.

PATTERN BOARD SCHEMATIC

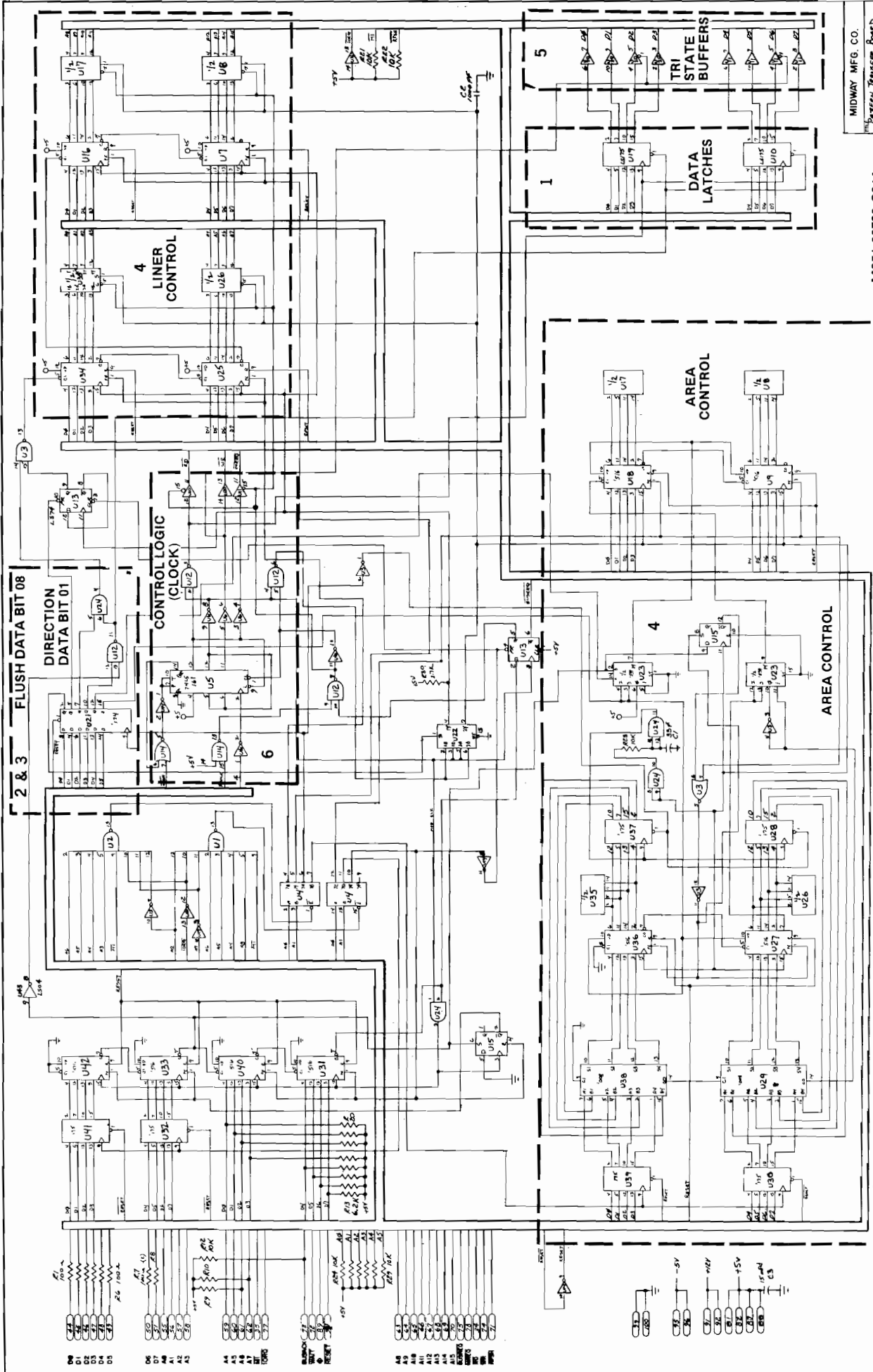

MIDWAY MFG. CO.
 THE SYSTEM TRANSFER BOARD
 C.G.R.S.
 #A082-91355-C000

M051-00780-C014

TROUBLE SHOOTING CARD RACK SYSTEM

All test points are found on the rear side of the Back Panel Board PC A082-93006-C/D000.

1. +5VDC PINS 87 AND 88.
2. +12VDC PINS 91 AND 92.
3. -5VDC PINS 95 AND 96.
4. LOGIC GROUND PINS 99 AND 100.
5. SYSTEM CLOCK 7.1MHZ PINS 97 AND 98.
6. VIDEO CLOCL 3.5MHZ PINS 93 (CHROM).
7. CPU CLOCK 1.7MHZ PINS 89 AND 90.
8. CPU RESET PIN 94 (NORMALLY HIGH).
9. DATA BITS (0-7) PINS 44 TO 51.
10. ADDRESS BITS (0-15) PINS 55 TO 70.
11. COMPOSITE VIDEO PIN 85.

For all Additional Test Points refer to Page #15.

BACK PANEL BOARD PC A082-93006 C/D000

PIN	DESIGNATION	DESCRIPTION	PIN	DESIGNATION	DESCRIPTION
1	S/L	Screen RAM Video Load Strobe	51	D7	Data Bit 7
2	WE	Write Enable	52	SCREEN	Screen RAM Decode
3	SER1	Serial Data 1	53	RMC0	Refresh Microcycle Control 0
4	SER0	Serial Data 0	54	RMC1	Refresh Microcycle Control 1
5	RAS3	Row Address Strobe 3	55	A0	Address Bit 0
6	RAS2	Row Address Strobe 2	56	A1	Address Bit 1
7	RAS1	Row Address Strobe 1	57	A2	Address Bit 2
8	RAS0	Row Address Strobe 0	58	A3	Address Bit 3
9	CAS	Column Address Strobe	59	A4	Address Bit 4
10	DATEN	Data Write Enable	60	A5	Address Bit 5
11	MA0	Multiplexed Address Bit 0	61	A6	Address Bit 6
12	MA1	Multiplexed Address Bit 1	62	A7	Address Bit 7
13	MA2	Multiplexed Address Bit 2	63	A8	Address Bit 8
14	MA3	Multiplexed Address Bit 3	64	A9	Address Bit 9
15	MA4	Multiplexed Address Bit 4	65	A10	Address Bit 10
16	MA5	Multiplexed Address Bit 5	66	A11	Address Bit 11
17	MD7	Memory Data Bus Bit 7	67	A12	Address Bit 12
18	MD6	Memory Data Bus Bit 6	68	A13	Address Bit 13
19	MD5	Memory Data Bus Bit 5	69	A14	Address Bit 14
20	MD4	Memory Data Bus Bit 4	70	A15	Address Bit 15
21	MD3	Memory Data Bus Bit 3	71	RFSH	Dynamic RAM Refresh
22	MD2	Memory Data Bus Bit 2	72	WAIT	Wait
23	MD1	Memory Data Bus Bit 1	73	BUSACK	Bus Acknowledge
24	MD0	Memory Data Bus Bit 0	74	WR	Write
25	BUFA0	Buffered Address Bit 0	75	BUSREQ	Bus Request
26	BUFA1	Buffered Address Bit 1	76	NMI	Non-maskable Interrupt
27	BUZOFF	Microcycle Data Bus Disable	77	IORQ	Input/Output Request
28	WATCHDOG	Automatic Reset	78	MREQ	Memory Request
29	LIGHTPEN	Lightpen Interrupt	79	HALT	Halt CPU stopped
30	VERTDR	Vertical Sync	80	INT	Interrupt Request
31	HORZDR	Horizontal Sync	81	+5v	Positive 5 volt Power Supply
32	MC0	Microcycle Control 0	82	+5v	Positive 5 volt Power Supply
33	MC1	Microcycle Control 1	83	R-Y	Red minus Video
34	RD	Read	84	B-Y	Blue minus Video
35	M1	Machine Opcode Cycle	85	VIDEO	Composite Video
36	MXD0	Microcycle Data Bus Bit 0	86	+2.5vREF	2.5 volt Chroma Center Reference
37	MXD1	Microcycle Data Bus Bit 1	87	+5v	Positive 5 volt Power Supply
38	MXD2	Microcycle Data Bus Bit 2	88	+5v	Positive 5 volt Power Supply
39	MXD3	Microcycle Data Bus Bit 3	89	Φ	CPU Clock 1.7897725 Mhz
40	MXD4	Microcycle Data Bus Bit 4	90	Φ	Opposite phase CPU Clock 1.7897725 Mhz
41	MXD5	Microcycle Data Bus Bit 5	91	+12v	Positive 12 volt Power Supply
42	MXD6	Microcycle Data Bus Bit 6	92	+12v	Positive 12 volt Power Supply
43	MXD7	Microcycle Data Bus Bit 7	93	CHROMA	3.579545 Mhz Chroma Subcarrier
44	D0	Data Bit 0	94	RESET	Reset
45	D1	Data Bit 1	95	-5v	Negative 5 volt Power Supply
46	D2	Data Bit 2	96	-5v	Negative 5 volt Power Supply
47	D3	Data Bit 3	97	7M	System Clock 7.15909 Mhz
48	D4	Data Bit 4	98	7M	Opposite phase system clock 7.15909 Mhz
49	D5	Data Bit 5	99	GND	System Power and Logic Ground
50	D6	Data Bit 6	100	GND	System Power and Logic Ground

1	V _{SS}	MXD7	40
2	SI0	MXD6	39
3	SI1	MXD5	38
4	SI2	MXD4	37
5	SI3	MXD3	36
6	SI4	MXD2	35
7	SI5	MXD1	34
8	SI6	MXD0	33
9	SI7	S00	32
10	POT0	S01	31
11	POT1	S02	30
12	POT2	S03	29
13	POT3	S04	28
14	DISCHG	S05	27
15	MONOS	S06	26
16	$\bar{\Phi}$	S07	25
17	RESET	AUDIO	24
18	TEST	\overline{RD}	23
19	\overline{IORQ}	V _{GG}	22
20	$\bar{\Phi}$	V _{DD}	21

CUSTOM I/O

1	V _{SS}	MA0	40
2	V _{DD}	\overline{IORQ}	39
3	MA0	MXD5	38
4	MA1	MXD4	37
5	MA2	MXD3	36
6	MA3	MXD2	35
7	MA4	MXD1	34
8	MA5	MXD0	33
9	RAS0	MXD6	32
10	RAS1	MXD7	31
11	RAS2	INT	30
12	RAS3	LIGHTPEN	29
13	TEST	$\bar{\Phi}$	28
14	WRCTL	$\bar{\Phi}$	27
15	LTCHDO	VERTDR	26
16	WAIT	HORZDR	25
17	MREQ	A15	24
18	MI	RFSH	23
19	A14	A12	22
20	RD	A13	21

CUSTOM ADDRESS

1	V _{SS}	DATEN	40
2	MXD6	MD5	39
3	MD6	MXD5	38
4	MXD7	MD4	37
5	MD7	MXD4	36
6	LTCHDO	PXCLK	35
7	\overline{RD}	MD3	34
8	MI	MXD3	33
9	$\overline{7M}$	MD2	32
10	7M	MXD2	31
11	SER0	MD1	30
12	SER1	MXD1	29
13	V _{GG}	MD0	28
14	VERTDR	MXD0	27
15	HORZDR	WRCTL	26
16	$\bar{\Phi}$	MREQ	25
17	MCI	VIDEO	24
18	MC0	2.5V	23
19	V _{DD}	R-Y	22
20	B-Y	\overline{IORQ}	21

CUSTOM DATA

I/O CHIP DESCRIPTION

The Z-80 communicates with the I/O Chip through Input and Output instructions. The state of an 8 x 8 switch matrix can be read through the Switch Scan circuit. When an Input instruction is executed, one of the SO0-SO7 lines will be activated. When a line is activated, the switch matrix will feed back eight bits of data on SI0-SI7. This data is in turn fed to the Z-80 through MUXD0 - MUXD7.

The Z-80 can read the position of four potentiometers (pots) through the A-D Converter circuit. The pots are continuously scanned by the A-D Converter and the results of the conversion are stored in a RAM with Input instructions.

The Z-80 loads data into the Music Processor with Output instructions. This data determines the characteristics of the audio that is generated.

ADDRESS CHIP DESCRIPTION

THE Microcycle Decoder generates twelve bits of Z-80 address from the 8-bit Microcycle Data Bus. This address is then fed through MUX I and MUX II to MA0-5 which go to the RAM. The Scan Address Generator generates a 12-bit address which is used to read video data from the RAM. This address goes from 0 to FFFH once every frame (1/60 sec.).

MUX I sends either the Scan Address or Z-80 Address to its 12 outputs. An output of the Scan Address Generator controls MUX I. If the Scan Address Generator and the Z-80 request a memory cycle at the same time, the Scan Address Generator will have higher priority and the Z-80 will be required to wait (by the $\overline{\text{WAIT}}$ output). The Scan Address Generator never requires the memory for more than one consecutive memory cycle, so the Z-80 is never required to wait for the memory for more than one cycle. HORIZ DR and VERT DR synchronize the Scan Address Generator with the Data Chip and the TV Scan.

The purpose of MUX II is to multiplex its 12 inputs to the six address bits in the two time slices required for 4K x 1 16 pin RAMS.

The Memory Cycle Generator controls memory cycles generated by either the Z-80 or Scan Address Generator. $\overline{\text{MREQ}}$, $\overline{\text{RD}}$, $\overline{\text{M1}}$, $\overline{\text{RFSH}}$, and A12-A15 are from the Z-80. A12-A15 are fed directly from the Z-80 because if they were brought out of the Microcycle Decoder, they would arrive too late in the memory cycle. The RAS0 - RAS3 outputs are used to activate memory cycle and all four RAS's are used to control four banks of RAM (16K x 8). WRCTL and LTCHD0 are control signals to the Data Chip. WRCTL tells the Data Chip when to place data to be written to memory on the Memory Data Bus. LTCHD0 tells the Data Chip when valid data from RAM is present on the Memory Data Bus.

DATA CHIP DESCRIPTION

The TV Sync Generator uses 7M and $\overline{7M}$ (7.159090 MHz square waves) to generate NTSC standard sync and blank to be sent to the Video Generator. It also generates HORIZ DR and VERT DR for synchronization with the Address Chip. HORIZ DR occurs once every horizontal line (63.5 usec), and VERT DR occurs once every frame (16.6 msec).

The Shift Register loads parallel data from the memory data bus (MD0 - MD7) and shifts it out of its two serial outputs. The TV Sync Generator controls when data is loaded or shifted. In a commercial game SERIAL 0 and SERIAL 1 are sent through the MUX I to MUX II. The two bits from MUX I select 8 bits to be sent through MUX II to the Video Generator. These 8 bits then determine the analog values of VIDEO, R-Y, and B-Y. 2.5V is a 2.5V D C reference level.

The Clock Generator generates 0G and \overline{PX} from 7M. These are the clocks for the rest of the system. The frequency of \overline{PX} is half that of 7M and the frequency of 0G is half that of \overline{PX} .

The Microcycle Generator generates the microcycle control bits, MC0 and MC1, from \overline{IORQ} , \overline{MREQ} , \overline{RD} , and $\overline{M1}$, all from the Z-80.

In memory write cycles WRCTL is activated and the Memory Control circuit generates \overline{DATEN} . The Magic Function Generator takes the data from the Z-80 on MUXD0 - D7 and transfers it to MD0 - MD7. If a Magic write is being done, the Magic Function Generator will modify the data as required before it places it on the memory data bus.

Z-80 CPU PIN DESCRIPTION

The Z-80 CPU is packaged in an industry standard 40 pin Dual In-Line Package. The I/O pins are shown in figure 3.0-1 and the function of each is described below.

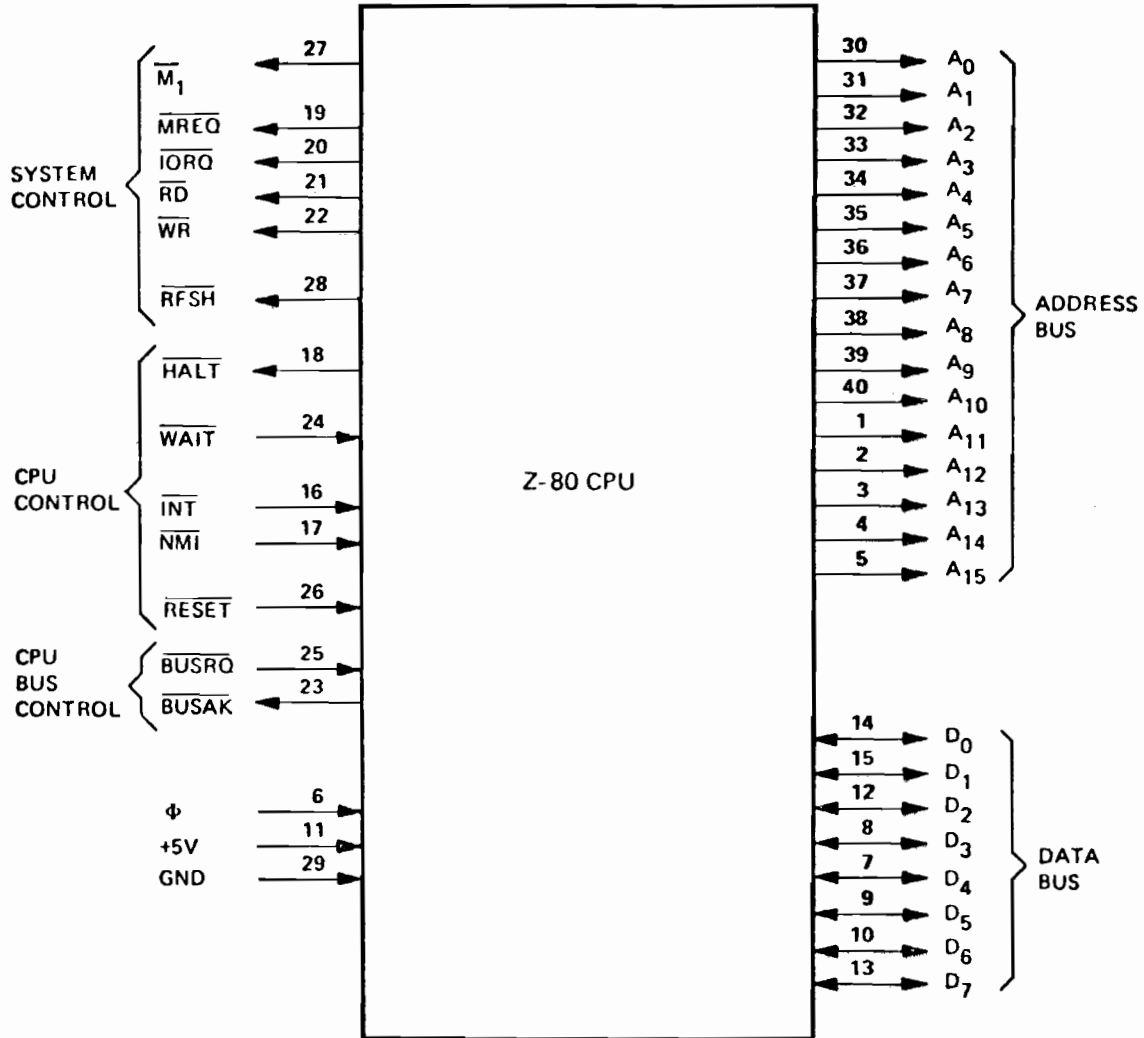

Z-80 PIN CONFIGURATION
FIGURE 3.0-1

SERVICE BULLETIN

GAME: WIZARD OF WOR

SUBJECT: NEW 6 CARD Z-80 SYSTEM USING A CARD RACK

GAME CARD (A084-90708-A961)
I & O CUSTOM CHIP (TWO)
TALKING CHIP - SC-01

ROM & RAM CARD (A084-91367-A961)
RAMS 2114
ROMS 9316 OR 9332

CPU CARD (A082-91354-F000)
Z80 CPU
ADDRESS CUSTOM CHIP
DATA CUSTOM CHIP
CRYSTAL 14, 318

RAM CARD (A082-91356-C000)
TWO RAM CARDS
16 RAM EACH (M4027)

PATTERN CARD (A082-91355-C000)
SHIFTS INFORMATION AT A FASTER RATE

POWER SUPPLY (A082-90411-B000)

NOTE: ALL PC CARDS EDGE CONNECTORS ARE GOLD PLATED.

ANDY DUCAY
SERVICE MANAGER

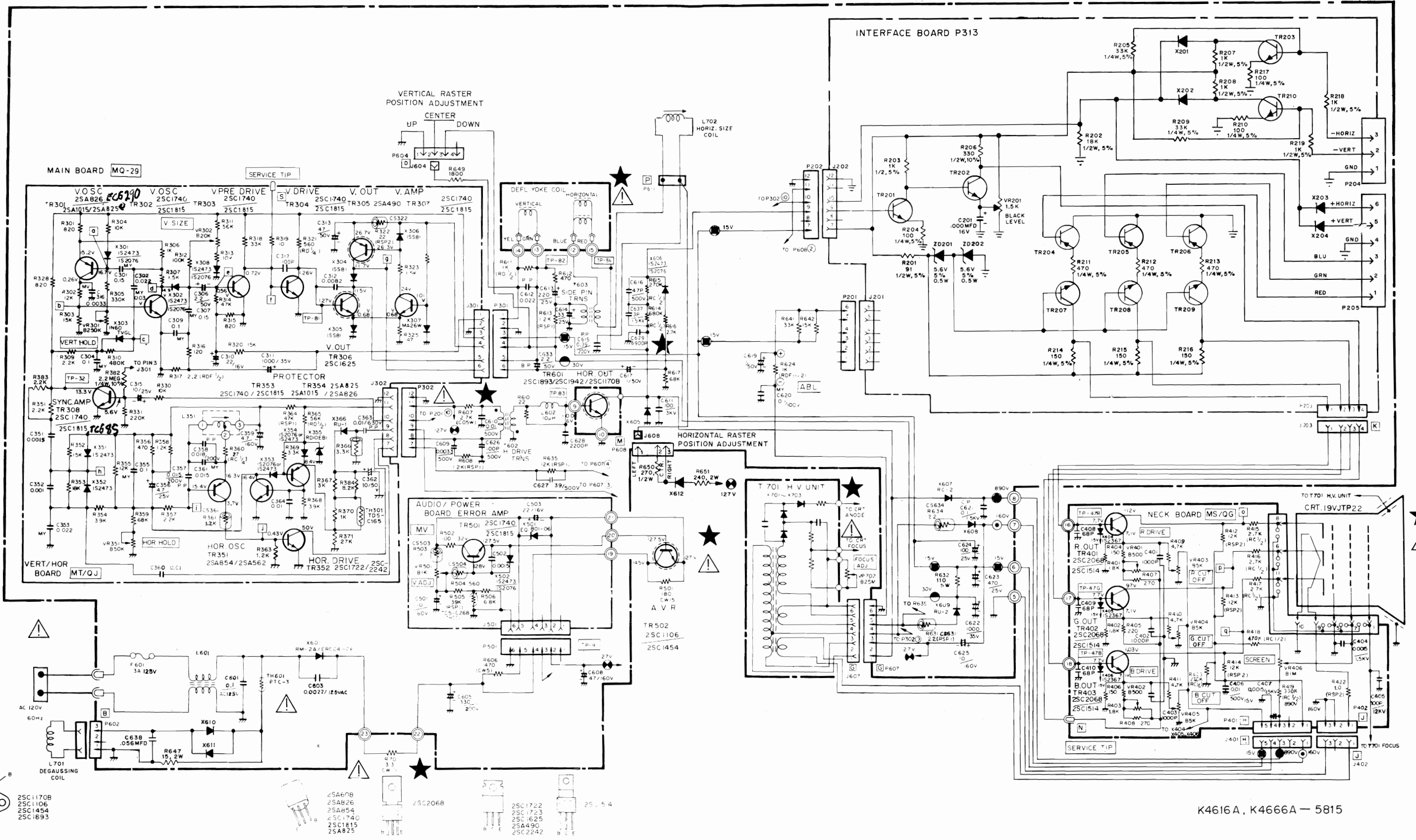

- 25C1170B
- 25C1106
- 25C1454
- 25C1693
- 25A608
- 25A826
- 25A854
- 25C1740
- 25C1815
- 25A490
- 25A825
- 25C206B
- 25C1722
- 25C1723
- 25C1625
- 25C1815
- 25C2242

VI. T.V. MONITOR MANUAL

VERT/HOR BOARD (MT/QJ)

Ref. No.	Part No.	Description	Ref. No.	Part No.	Description
RESISTORS			CAPACITORS (CONT.)		
R301	203X6500-628	820 Ohm, ± 5%, 1/8W Carbon	C313	203X0025-087	47 uF, 50V Electrolytic
R302	203X6500-902	12k Ohm, ± 5%, 1/8W Carbon	C315	203X0015-082	10 uF, 25V Electrolytic
R303	203X6500-927	15k Ohm, ± 5%, 1/8W Carbon	C316	203X1100-220	3300 uF, 50V, ± 10% Mylar
R304	203X6500-886	10k Ohm, ± 5%, 1/8W Carbon	C317	202X8000-616	100 pF, 50V, ± 10% Ceramic
R305	203X6501-241	330k Ohm, ± 5%, 1/8W Carbon	C351	202X7000-281	1500 pF, 50V, ± 10% Ceramic
R306	203X6500-645	1k Ohm, ± 5%, 1/8W Carbon	C352	202X7000-247	1000 pF, 50V, ± 10% Ceramic
R307	203X6500-689	1.5k Ohm, ± 5%, 1/8W Carbon	C353	203X1100-573	0.022 uF, 50V, ± 10% Mylar
R309	203X6500-724	2.2k Ohm, ± 5%, 1/8W Carbon	C355	203X1100-858	0.1 uF, 50V, ± 10% Mylar
R310	203X6501-285	470k Ohm, ± 5%, 1/8W Carbon	C356	203X0015-105	4.7 uF, 25V Electrolytic
R311	203X6501-065	56k Ohm, ± 5%, 1/8W Carbon	C357	203X1201-013	0.015uF, 200V ± 10% PP
R312	203X6501-126	100k Ohm, ± 5%, 1/8W Carbon	C358	203X1201-034	0.018 uF, 200V, ± 10% PP
R313	203X6001-326	10k Ohm, ± 5%, 1/8W Carbon	C359	203X0040-013	4.7 uF, 160V Electrolytic
R314	203X6501-044	47k Ohm, ± 5%, 1/8W Carbon	C360	202X7000-482	0.01 uF, 50V, ± 10% Ceramic
R315	203X6500-628	820 Ohm, ± 5%, 1/8W Carbon	C361	203X1100-509	0.015 uF, 50V, ± 10% Mylar
R316	203X6500-420	120 Ohm, ± 5%, 1/8W Carbon	C362	203X0025-058	10 uF, 50V Electrolytic
R317	203X6206-441	2.2 Ohm, ± 5%, 1/2W Carbon	C363	203X1205-487	0.01 uF, 630V, ± 10% PP
R319	203X6500-169	100 Ohm, ± 5%, 1/8W Carbon	C364	202X7000-482	0.01 uF, 50V, ± 10% Ceramic
R320	203X6500-927	15k Ohm, ± 5%, 1/8W Carbon			
R321	203X6700-509	560 Ohm, ± 5%, 1/2W Carbon			
R322	203X9100-121	22 Ohm, ± 5%, 2W M.O.			
R323	203X6500-689	1.5K Ohm, ± 5%, 1/8W Carbon			
R324	203X6500-988	27k Ohm, ± 5%, 1/8W Carbon	TR301	200X4082-614	Transistor, 2SA826Q
R325	203X6500-326	47 Ohm, ± 5%, 1/8W Carbon	TR302	200X3174-006	Transistor, 2SC1740Q
R328	203X6500-628	820 Ohm, ± 5%, 1/8W Carbon	TR303	200X3174-006	Transistor, 2SA1740Q
R330	203X6500-886	10k Ohm, ± 5%, 1/8W Carbon	TR304	200X3174-006	Transistor, 2SC1740Q
R331	203X6501-209	220k Ohm, ± 5%, 1/8W Carbon	TR305	200X4049-081	Transistor, 2SA490YLBGLI
R351	203X6500-724	2.2k Ohm, ± 5%, 1/8W Carbon	TR306	200X3162-538	Transistor, 2SC1625YLBGLI
R352	203X6500-927	15k Ohm, ± 5%, 1/8W Carbon	TR307	200X3174-014	Transistor, 2SC1740R
R353	203X6500-944	18k Ohm, ± 5%, 1/8W Carbon	TR308	200X3174-006	Transistor, 2SC1740Q
R354	203X6500-783	3.9k Ohm, ± 5%, 1/8W Carbon	TR351	200X4085-415	Transistor, 2SA854Q
R355	203X6500-902	12k Ohm, ± 5%, 1/8W Carbon	TR352	200X3172-208	Transistor, 2SC1722BKS
R356	203X6500-561	470 Ohm, ± 5%, 1/8W Carbon	TR353	200X3174-006	Transistor, 2SC1740Q
R357	203X6500-724	2.2k Ohm, ± 5%, 1/8W Carbon	TR354	200X4082-614	Transistor, 2SA826Q
R358	203X6500-666	1.2k Ohm, ± 5%, 1/8W Carbon	X301	201X2010-144	Diode, (SI) IS2473-T72
R359	203X6501-088	68k Ohm, ± 5%, 1/8W Carbon	X302	201X2010-144	Diode, (SI) IS2473-T72
R360	203X5500-471	27 Ohm, ± 5%, 1/4W Comp.	X303	200X8000-026	Diode, (GE) IN60TVGL
R361	203X6000-998	1.2k Ohm, ± 5%, 1/8W Carbon	X304	200X8010-165	Diode (SI) ISS81
R363	203X6500-666	1.2k Ohm, ± 5%, 1/8W Carbon	X305	201X2010-165	Diode (SI) ISS81
R364	203X9014-988	47k Ohm, ± 5%, 1W M.O.	X306	201X2010-165	Diode (SI) ISS81
R365	203X6700-989	56k Ohm, ± 5%, 1/2W Carbon	X307	200X8010-102	Diode (SI) MA26W
R366	203X6001-148	3.3k Ohm, ± 5%, 1/8W Carbon	X308	200X8010-094	Diode (SI) IS2473
R367	340X2222-734	2.2k Ohm, ± 5%, 1/2W Carbon	X351	201X2010-144	Diode (SI) IS2473-T72
R368	203X6500-785	3.9k Ohm, ± 5%, 1/8W Carbon	X352	201X2010-144	Diode (SI) IS2473-T72
R369	203X6500-762	3.3k Ohm, ± 5%, 1/4W Carbon	X353	201X2010-144	Diode (SI) IS2473-T72
R370	302X6100-961	1k Ohm, ± 5%, 1/4W Carbon	X354	201X2010-144	Diode (SI) IS2473-T72
R371	203X6104-751	2.7k Ohm, ± 5%, 1/4W Carbon	X355	200X8220-851	Diode (Zener) RD10EBI
VR301	204X2122-093	Varistor, 250K Ohm, Vert. Hold	X366	200X8100-130	Diode (HS) RU-1 0.3 US
VR302	204X2114-065	Varistor, 20K Ohm, Vert. Size			
VR351	204X2114-059	Varistor, 50K Ohm, Hor. Hold			
CAPACITORS			MISCELLANEOUS		
C301	203X1100-928	0.15 uF, 50V, ± 10% Mylar	J301	204X9300-958	Socket, 6 Pin
C302	203X1100-573	0.022 uF, 50V, ± 10% Mylar	J302	204X9300-958	Socket, 6 Pin
C304	203X1100-858	0.1 uF, 50V, ± 10% Mylar	P301	204X9601-195	Plug, 6 Pin
C306	203X0025-026	2.2 uF, 50V, Electrolytic	P302	204X9601-195	Plug, 6 Pin
C307	203X1100-928	0.15 uF, 50V, ± 10% Mylar	TH301	201X0000-534	Thermistor
C309	203X1100-858	0.1 uF, 50V, ± 10% Mylar			
C310	203X0010-011	22 uF, 16V Electrolytic			
C311	203X0020-099	1000 uF, 35V Electrolytic			
C312	202X7000-469	0.0082 uF, 50V, ± 10% Ceramic	L351	201X5200-091	Coil, Horiz. Osc.
POWER BOARD (MV)			TRANSFORMERS & COILS		
RESISTORS			C503	203X0010-011	22 uF, 16V Electrolytic
RESISTORS			C551	203X0005-046	220 uF, 10V Electrolytic
R501	204X1725-052	180 Ohm, ± 10%, 15W WW			
R502	203X6000-608	100 Ohm, ± 5%, 1/8W Carbon			
R503	203X6000-960	1k Ohm, ± 5%, 1/8W Carbon			
R504	203X6000-879	560 Ohm, ± 5%, 1/8W Carbon			
R505	203X9014 965	39k Ohm, ± 5%, 1W M.O.	TR501	200X3174-006	Transistor, 2SC1740Q
R506	203X6500-842	6.8k Ohm, ± 5%, 1/8W Carbon	★ TR502	200X3145-404	Transistor, 2SC1454
R551	203X6500-420	120 Ohm, ± 5%, 1/8W Carbon	TR551	200X3172-305	Transistor, 2SC1723
VR501	204X2050-001	Varistor Vert. Adj.	X501	201X2230-042	Diode, (SI) Zener EQB01-06V
			X502	201X2010-144	Diode, (SI) IS2473-T72
CAPACITORS			MISCELLANEOUS		
C501	203X0040-020	10 uF, 160V Electrolytic	J501	204X9300-958	Socket, 6 Pin
C502	202X7000-281	1500 pF, 50V, ± 10% Ceramic	P501	204X9601-195	Plug, 6 Pin
			TH501	201X0000-618	Thermistor

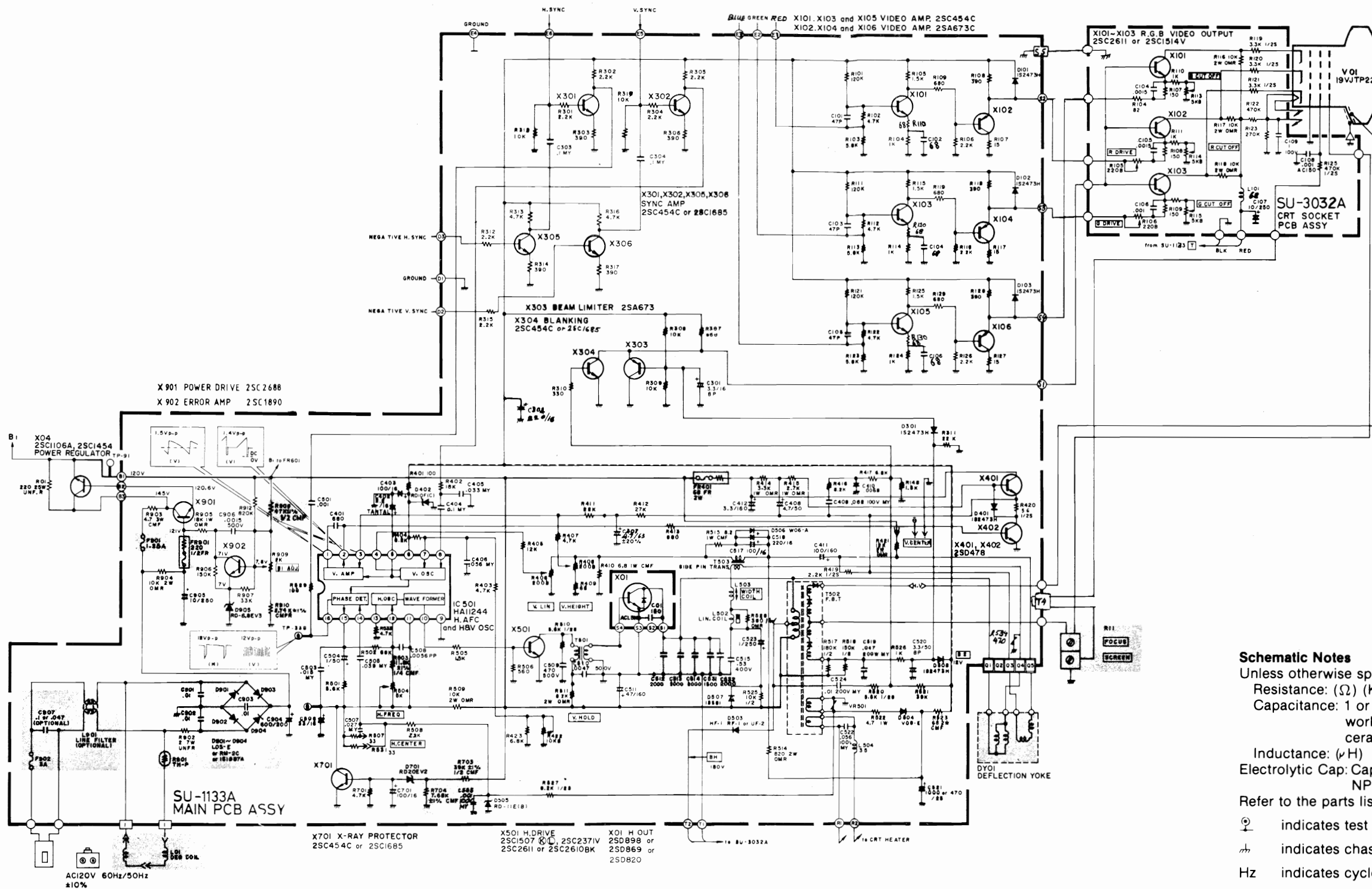

Schematic Notes

- Unless otherwise specified
- Resistance: (Ω) (K \rightarrow K Ω , M \rightarrow M Ω), 1/4 (W) carbon resistor
- Capacitance: 1 or higher \rightarrow (pF), less than 1 \rightarrow (μ F)
- working voltage \rightarrow 50 (V)
- ceramic capacitor
- Inductance: (μ H)
- Electrolytic Cap: Capacitance Value (μ F)/working voltage (V),
- NP \rightarrow non-polar (or bipolar) electrolytic cap.
- Refer to the parts list for additional component information.
- $\text{\textcircled{P}}$ indicates test point connection
- $\text{\textcircled{G}}$ indicates chassis ground unless otherwise specified
- Hz indicates cycles per second

For **safety** purposes (and continuing reliability)

- $\text{\textcircled{\Delta}}$ replace all components marked with safety symbol with identical type.
- NOTE: FR \rightarrow fusible resistor $\text{\textcircled{\text{FR}}}$

00-4147-04
G07-CB0

Parts identification on circuit boards:
e.g. SU1126A (R107 = R1107)
SU3030A (R113 = R3113)

REPLACEMENT PARTS LIST - ELECTROHOME 19" MONITOR

Components identified by the \triangle symbol in the PARTS LIST and on the Schematic have special characteristics important to safety.

DO NOT degrade the safety of the set through improper servicing.

Abbreviations for Resistors and Capacitors

Resistor

C R	:	Carbon Resistor
Comp. R	:	Composition Resistor
OM R	:	Oxide Metal Film Resistor
V R	:	Variable Resistor
MF R	:	Metal Film Resistor
CMF R	:	Coating Metal Film Resistor
UNF R	:	Nonflammable Resistor
F R	:	Fusible Resistor

Capacitor

C Cap.	:	Ceramic Capacitor
M Cap	:	Mylar Capacitor
E Cap.	:	Electrolytic Capacitor
BP E Cap.	:	Bi-Polar (or Non-Polar) Electrolytic Capacitor
MM Cap.	:	Metalized Mylar Capacitor
PP Cap.	:	Polypropylene Capacitor
MPP Cap.	:	Metalized PP Capacitor
PS Cap	:	Polystyrol Capacitor
Tan. Cap.	:	Tantal Capacitor

NOTE: When ordering replacement parts please specify the part number as shown in this list including part name, and model number. Complete information will help expedite the order.

Use of substitute replacement parts which do not have the same safety characteristics as specified, may create shock, fire or other hazards. For maximum reliability and performance, all parts should be replaced by those having identical specifications.

SERVICE REPLACEMENT PARTS LIST

Symbol	Description	Part Number
	Main P.C.B. Ass'y	SU-1133A
	CRT Socket P.C.B. Ass'y	SU-3032A
	Purity Shield Ass'y	07-220083-03

Outside of the P.C.B. Ass'y

Symbol	Description	Part Number
	Picture Tube 19'	17-7198-03
△	△Deflection Yoke	A29779-D = 21-141-01
	PC Magnet	A75034-B = 29-32-01
△	△Flyback Transf.	A29951-B
△	△HVR	A46600-A
R05	UNF Resistor 220Ω, 25W K	QRF258K-221
C04	C Capacitor 150pF, AC1.5KV	QCZ0101-005
X01	Si. Transistor	2SD870
X02	Si. Transistor	2SC1106A
SC	Screw #8-3/8	31-610818-06
SC	Screw 1/4 x 3/4 Pix Tube Mtg. (4)	31-601418-12
WA	Pyramidal Lock Washer (4)	33-255-01
	Nut Retainer, Pix Tube Mtg. (4)	33-494-01
	Clip — P.C.B. Support	33-629-02
	Standoff	33-670-010R-02
	Wire Terminal (Gnd. Strap)	34-228-03
	Terminal Lug (Gnd.)	34-33-04
	Groundstrap Assy.	34-574-02
	Grounding Spring	35-212-03
	Wire Hook (Gnd. Strap)	35-3053-02
	Purity Shield Holddown Clamp	35-2348-01
	Support Brkt. RH	35-3890-01
	Support Brkt. LH	35-3890-02
	Chassis Base	38-449-02
	Yoke Wedge (3)	39-1233-01

Purity Shield Ass'y. Parts List

Symbol	Description	Part Number
D911, D912	Degaussing Coil	21-1007-30
	Rectifier 1 Amp 600V (2)	28-22-27
	Pin Terminal (2)	34-708-01
	Pin Terminal Housing	34-709-01
	Purity Shield (2 pcs.)	35-3847-01
	Purity Shield (2 pcs.)	35-3847-02
C911	Capacitor 100nF 10% 400V	48-171544-62
R921	Resistor, Wirewound 33Ω, 4W	42-113301-03
	Fire Retardent Term. Strip 4 Lug	34-492-09

CRT Socket P.C.B. Ass'y (SU-3032A) Parts List

Resistors

Symbol	Description	Part Number
R3105	V R 200	QVZ3234-022
R3106	V R 200	QVZ3234-022
R3113	V R 5K	QVZ3234-053
R3114	V R 5K	QVZ3234-053
R3115	V R 5K	QVZ3234-053
R3116	OM R 10KΩ2W J	QRG029J-103
R3117	OM R 10KΩ2W J	QRG029J-103
R3118	OM R 10KΩ2W J	QRG029J-103
R3119	Comp. R 3.3KΩ1/2W K	QRZ0039-332
R3120	Comp. R 3.3KΩ1/2W K	QRZ0039-332
C3121	Comp. R 3.3KΩ1/2W K	QRZ0039-332

Capacitors

Symbol	Description	Part Number
C3107	E Cap. 10uF 250V A	QEW53EA-106
C3108	C Cap. 1000pF DC1400V P	QCZ9001-102M

Coils

Symbol	Description	Part Number
L3101	Peaking Coil	QQL043K-101

Semiconductors

Symbol	Description	Part Number
X3101	Si. Transistor	2SC1514VC
X3102	Si. Transistor	2SC1514VC
X3103	Si. Transistor	2SC1514VC

Miscellaneous

Symbol	Description	Part Number
△	△CRT Socket	A76068

Main PCB Ass'y (SU-1133A) Parts List**Resistors**

Symbol	Description	Part Number
R1406	V R 200Ω	QVZ3230-002
R1408	V R 200Ω	QVZ3230-002
R1410	CMF R 6.8Ω1W J	QRX019J-6R8
R1414	OM R 3.3KΩ1W J	QRG019J-332
R1415	OM R 2.7KΩ1W J	QRG019J-272
R1421	OM R 12KΩ2W J	QRG026J-123Z
R1422	V R 10KΩ	QVZ3230-014
△FR1401	△F R 68Ω2W K	QRH024K-680M
△R1503	△CMF R 11.8KΩ¼W +1%	QRV142F-1182
R1504	V R 5KΩ	QVZ3230-053
R1509	OM R 10KΩ2W J	QRG026J-103Z
R1512	OM R 8.2KΩ2W J	QRG026J-822Z
R1514	OM R 820Ω2W J	QRG026J-821Z
R1515	CMF R 8.2Ω1W J	QRX019J-8R2
R1522	CMF R 4.7Ω1W J	QRX019J-4R7
R1523	OM R 68Ω2W J	QRG026J-680Z
R1528	OM R 390Ω1W J	QRG019J-391
R1534	ZN R	ERZ-C05ZK471
VR1501	ZN R	ERZ-C05DK271
△R1703	△CMF R 39Ω½W +1%	QRV122F-3902
△R1704	△CMF R 7.68KΩ¼W +1%	QRV142F-7681
△R1901	△Posistor	A75414
R1902	UNF R 2Ω7W K	QRF076K-2R0
R1903	CMF R 4.7Ω3W J	QRX039J-4R7
R1904	OM R 10KΩ2W J	QRG026J-103Z
R1905	OM R 18KΩ1W J	QRG019J-183
△Q1908	△CMF R 47Ω½W +1%	QRV122F-470Z
△R1909	V R 2KΩ	QVP5A0B-023E
R1910	△CMF R 2.74KΩ¼W +1%	QRV142F-274I
△FR1901	△F R 220Ω½W K	QRH124K-221M

Capacitors

Symbol	Description	Part Number
C1301	BPE Cap. 3.3uF 50V A	QEN61HA-335Z
C1402	Tan. Cap. 2.2uF 16V K	QEE51CK-225B
C1407	E Cap. 4.7uF 6.3V A	QEW51JA-475
C1411	E Cap. 100uF 160V A	QEW52CA-107
C1412	E Cap. 3.3uF 160V A	QEW52CA-335
C1508	PP Cap. 5600uF 50V J	QFP31HJ-562
△C1512	△PP Cap. 2000pF DC1500V J	QFZ0082-202
△C1513	△PP Cap. 2000pF DC1500V J	QFZ0082-202
△C1514	△PP Cap. 2000pF DC1500V J	QFZ0082-202
C1515	PP Cap. 0.53uF DC1200V J	QFZ0067-534
C1520	BPE Cap. 3.3uF 50V A	QEN61HA-335Z
C1523	E Cap. 1uF 160V A	QEW62CA-105Z
C1524	M Cap. 0.1uF 200V K	QFM720K-104M
△C1531	△PP Cap. 2000pF DC1500V J	QFZ0082-202
△C1532	△PP Cap. 1500pF DC1500V J	QFZ0082-152
C1904	E Cap.	QEY0034-001
C1905	E Cap. 10uF 250V A	QEW52EA-106

Coils	Description	Part Number
Symbol		
L1502	Linearity Coil	A39835
L1503	Width Coil	C30380-A
L1504	Heater Choke	C30445-A
Transformers		
Symbol	Description	Part Number
T1501	Hor. Drive Transf.	A46022-BM
T1503	Side Pin Transf.	C39050-A
Semiconductors		
Symbol	Description	Part Number
IC1501	IC	HA11244
X1101	Si. Transistor	2SC1685(R)
X1102	Si. Transistor	2SA673(C)
X1103	Si. Transistor	2SC1685(R)
X1104	Si. Transistor	2SA673(C)
X1105	Si. Transistor	2SC1685(R)
X1106	Si. Transistor	2SA673(C)
X1301	Si. Transistor	2SC1685(R)
X1302	Si. Transistor	2SC1685(R)
X1303	Si. Transistor	2SA673(C)
X1304	Si. Transistor	2SC1685(R)
X1305	Si. Transistor	2SC1685(R)
X1401	Si. Transistor	2SD478
X1402	Si. Transistor	2SD478
X1501	Si. Transistor	2SC2610BK
X1901	Si. Transistor	2SC2688 (K.L.M.)
X1902	Si. Transistor	2SC1890A (E.F.)
D1101	Si. Diode	W06A
D1102	Si. Diode	W06A
D1103	Si. Diode	W06A
D1301	Si. Diode	1SZ473H
D1401	Si. Diode	1SZ473H
D1402	Zener Diode	RD10F(C)
D1503	Si. Diode	HF-1
D1504	Si. Diode	V09E
D1505	Zener Diode	RD11E(B)
D1506	Si. Diode	W06A
D1507	Si. Diode	1SS81
D1508	Si. Diode	1SZ473H
△D1701	△Zener Diode	RD20EV2
△D1901	△Si. Diode	1S1887A
△D1902	△Si. Diode	1S1887A
△D1903	△Si. Diode	1S1887A
△D1904	△Si. Diode	1S1887A
△D1905	△Zener Diode	RD6.8EV3
Miscellaneous		
Symbol	Description	Part Number
△F1901	△Fuse 1.25A	QMF53U1-1R25S
△F1902	△UL Fuse 3A	QMF66U1-3R0S

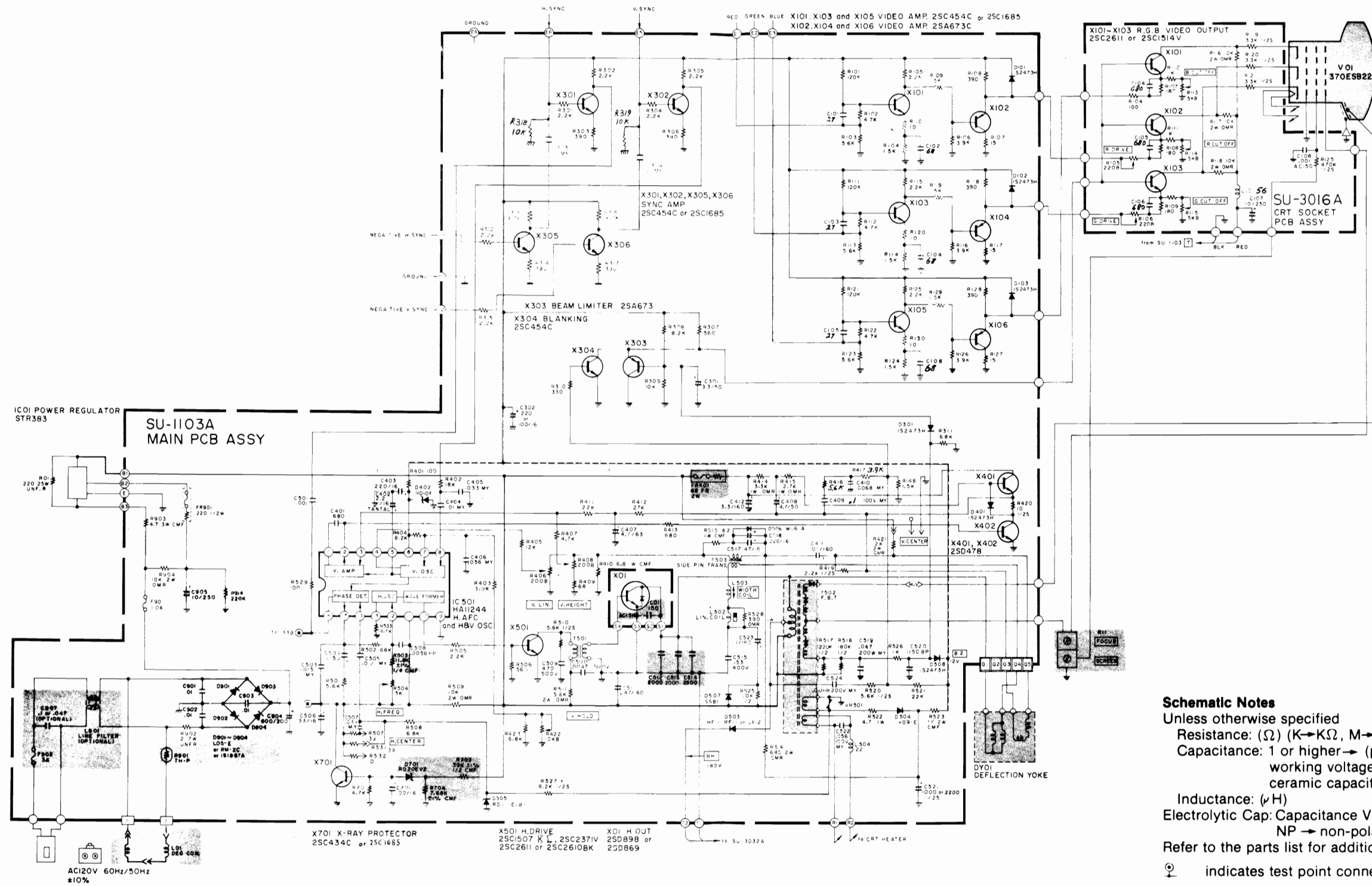

Schematic Notes
 Unless otherwise specified
 Resistance: (Ω) (K \rightarrow K Ω , M \rightarrow M Ω), 1/4 (W) carbon resistor
 Capacitance: 1 or higher \rightarrow (pF), less than 1 \rightarrow (μ F)
 working voltage \rightarrow 50 (V)
 ceramic capacitor
 Inductance: (μ H)
 Electrolytic Cap: Capacitance Value (μ F)/working voltage (V),
 NP \rightarrow non-polar (or bipolar) electrolytic cap.
 Refer to the parts list for additional component information.

\oplus indicates test point connection
 \perp indicates chassis ground unless otherwise specified
 Hz indicates cycles per second

For **safety** purposes (and continuing reliability)
 \triangle replace all components marked with safety symbol with identical type.
 NOTE: FR \rightarrow fusible resistor

G07-FBO
 00-4147-03

Parts identification on circuit boards:
 e.g. SU1126A (R107 = R1107)
 SU3030A (R113 = R3113)

REPLACEMENT PARTS LIST - ELECTROHOME 13" MONITOR

Components identified by the \triangle symbol in the PARTS LIST and on the Schematic have special characteristics important to safety.

DO NOT degrade the safety of the set through improper servicing.

Abbreviations for Resistors and Capacitors

Resistor

C R	: Carbon Resistor
Comp. R	: Composition Resistor
OM R	: Oxide Metal Film Resistor
V R	: Variable Resistor
MF R	: Metal Film Resistor
CMF R	: Coating Metal Film Resistor
UNF R	: Nonflammable Resistor
F R	: Fusible Resistor

Capacitor

C Cap.	: Ceramic Capacitor
M Cap	: Mylar Capacitor
E Cap.	: Electrolytic Capacitor
BP E Cap.	: Bi-Polar (or Non-Polar) Electrolytic Capacitor
MM Cap.	: Metalized Mylar Capacitor
PP Cap.	: Polypropylene Capacitor
MPP Cap.	: Metalized PP Capacitor
PS Cap	: Polystyrol Capacitor
Tan. Cap.	: Tantal Capacitor

NOTE: When ordering replacement parts please specify the part number as shown in this list including part name, and model number. Complete information will help expedite the order.

Use of substitute replacement parts which do not have the same safety characteristics as specified, may create shock, fire or other hazards. For maximum reliability and performance, all parts should be replaced by those having identical specifications.

Symbol	Description	Part Number
	Main P.C.B. Ass'y	SU-1103A
	CRT Socket P.C.B. Ass'y	SU-3016A
Outside of the P.C.B. Ass'y		
Symbol	Description	Part Number
\triangle V01	\triangle Picture Tube	370ESB22(E)
\triangle DY01	\triangle Deflection Yoke	C29123-V
	PC Magnet	A76366-A
	Wedge	C30006
	\triangle Flyback Transf.	A19183-A
\triangle R11	\triangle Focus V R	A46606-A
\triangle R05	UNF Resistor 220 Ω , 25W. K	QRF258K-221
\triangle C04	\triangle C Capacitor 150 pF, AC1.5KV	QCZ0101-005
X01	Si. Transistor	2SD869
IC01	IC Regulator	STR383
L01	Degaussing Coil	21-1007-31
	Degaussing Coil Pin Terminal (2)	34-708-01
	Degaussing Coil Pin Terminal Housing	34-709-01
	Groundstrap Ass'y.	34-697-04
	Groundstrap Wire Terminal	34-228-03
	Groundstrap Spring (2)	35-3560-01
BR	Support Bracket RH	35-3919-01
BR	Support Bracket LH	35-3919-02
SC	SCREW 10- $\frac{1}{2}$ Pix Tube Mtg. (4)	31-631018-08
WA	Pyramidal Lockwasher (4)	33-255-01
	Clip P.C.B. Support (2)	33-629-02
	Ground Lug	34-33-04
CH	Chassis Base	38-452-01

Main P.C.B. Ass'y (SU-1103A) Parts List

Resistors

Symbol	Description	Part Number
R1406	V R 200 Ω	QVZ3230-022
R1408	V R 200 Ω	QVZ3230-022
R1410	CMF R 6.8 Ω 1W J	QRX019J-6R8
R1414	OM R 3.3K Ω 1W J	QRG019J-332
R1415	OM R 2.7K Ω 1W J	QRG019J-272
R1421	OM R 12K Ω 2W J	QRG029J-123
R1422	V R 10K Ω	QVZ3224-014H
△FR1401	△F R 68 Ω 2W K	QRH024K-680M
△R1503	△CMF R 11.8K Ω ¼W +1%	QRV142F-1182
R1504	V R 5K Ω	QVZ3230-053
R1509	OM R 10K Ω 2W J	QRG029J-103
R1511	OM R 5.6K Ω 2W J	QRG029J-562
R1514	OM R 680 Ω 2W J	QRG029J-681
R1515	CMF R 8.2 Ω 1W J	QRX019J-8R2
R1522	CMF R 4.7 Ω 1W J	QRX019J-4R7
R1523	OM R 56 Ω 2W J	ORG029J-560
R1528	OM R 390 Ω 1W J	ORG019J-391
R1534	ZN R	ERZ-C05ZK471
VR1501	ZN R	ERZ-C05DK271
△R1703	△CMF R 39K Ω ½W +1%	QRV122F-3902
△R1704	△CMF R 7.68K Ω ¼W +1%	QRV142F-7681
△R1901	△Posistor	A75414
R1902	UNF R 2 Ω 7W K	QRF076K-2R0
R1903	CMF R 5.6 Ω 3W J	QRX039J-5R6
R1904	OM R 10K Ω 2W J	QRG026J-103Z
△FR1901	△F R 220 Ω ½W K	QRH124K-221M

Capacitors

Symbol	Description	Part Number
C1402	Tan. Cap. 2.2uF 16V K	QEE51CK-225B
C1411	E Cap. 100uF 160V A	QEW52CA-107
C1412	E Cap. 3.3uF 160V A	QEW52CA-335
C1508	PP Cap. 5600pF 50V J	QFP31HJ-562
C1511	E Cap. 47uF 160V A	QEW52CA-476S
△C1512	△PP Cap. 2000pF DC1500V J	QFZ0082-202
△C1513	△PP Cap. 2000pF DC1500V J	QFZ0082-202
△C1514	△PP Cap. 2500pF DC1500V J	QFZ0082-252
C1515	PP Cap. 0.53uF DC1200V K	QFZ0067-534
C1520	BPE Cap. 1uF 50V A	QEN61HA-105Z
C1524	M Cap. 0.1uF 200V K	QFM72DK-682M
C1904	E Cap.	QEY0034-001
C1905	E Cap. 10uF 250V A	QEW52EA-106
△C1907	△MM Cap. 0.1uF AC150V Z	QFZ9008-104

Coils

Symbol	Description	Part Number
L1501	Peaking Coil	A75360-6
L1502	Linearly Coil	A39934
L1503	Width Coil	C30380-A
L1504	Heater Choke	C30333-A
L1901	Line Filter	A39475-J

Transformers

Symbol	Description	Part Number
T1501	Hor. Drive Transf.	A46022-BM
T1503	Side Pin Transf.	C39050-A

Semiconductors

Symbol	Description	Part Number
IC1501	I.C.	HA11244
X1101	Si. Transistor	2SC1685(R)
X1102	Si. Transistor	2SA673(C)
X1103	Si. Transistor	2SC1685(R)
X1104	Si. Transistor	2SA673(C)
X1105	Si. Transistor	2SC1685(R)
X1106	Si. Transistor	2SA673(C)
X1301	Si. Transistor	2SC1685(R)
X1302	Si. Transistor	2SC1685(R)
X1303	Si. Transistor	2SA673(C)
X1304	Si. Transistor	2SC1685(R)
X1305	Si. Transistor	2SC1685(R)
X1401	Si. Transistor	2SD478
X1402	Si. Transistor	2SD478
X1501	Si. Transistor	2SC2610BK
X1701	Si. Transistor	2SC1685(P-S)
D1101	Si. Diode	W06A
D1102	Si. Diode	W06A
D1103	Si. Diode	W06A
D1301	Si. Diode	1S2473H
D1401	Si. Diode	1S2473H
D1402	Zener Diode	RD10F(C)
D1503	Si. Diode	HF-1
D1504	Si. Diode	V09E
D1505	Zener Diode	RD11E(B)
D1506	Si. Diode	W06A
D1507	Si. Diode	1SS81
D1508	Si. Diode	1S2473H
△D1701	△Zener Diode	RD20EV2
△D1901	△Si. Diode	1S1887A
△D1902	△Si. Diode	1S1887A
△D1903	△Si. Diode	1S1887A
△D1904	△Si. Diode	1S1887A

Miscellaneous

Symbol	Description	Part Number
△F1901	△Fuse 1A	QMF53U1-1R0S
△F1902	△UL Fuse 3A	QMF66U1-3R0S

CRT Socket P.C.B. Ass'y (SU-3016A) Parts List

Resistors

Symbol	Description	Part Number
R3105	V R 200Ω	QVZ3234-022
R3106	V R 200Ω	QVZ3234-022
R3113	V R 5KΩ	QVZ3234-053
R3114	V R 5KΩ	QVZ3234-053
R3115	V R 5KΩ	QVZ3234-053
R3116	OM R 10KΩ2W J	QRG029J-103
R3117	OM R 10KΩ2W J	QRG029J-103
R3118	OM R 10KΩ2W J	QRG029J-103
R3119	Comp. R 3.3KΩ½W K	QRZ0039-332
R3120	Comp. R 3.3KΩ½W K	QRZ0039-332
R3121	Comp. R 3.3KΩ½W K	QRZ0039-332

Capacitors

Symbol	Description	Part Number
C3107	E Cap. 10uF 250V A	QEW52EA-106
C3108	C Cap. 1000pF DC1400V P	QCZ9001-102M

Coils

Symbol	Description	Part Number
L3101	Peaking coil	QQL043K-101

Semiconductors

Symbol	Description	Part Number
X3101	Si. Transistor	2SC2611
X3102	Si. Transistor	2SC2611
X3103	Si. Transistor	2SC2611

Miscellaneous

Symbol	Description	Part Number
△	△ CRT Socket	A75522

WELLS-GARDENER

INSTALLATION AND SERVICE INSTRUCTIONS

COLOR PURITY AND VERTICAL CENTERING ADJUSTMENT

For best results, it is recommended that the purity adjustment be made in the final monitor location. If the monitor will be moved, perform this adjustment with it facing west or east. The monitor must have been operating 15 minutes prior to this procedure and the faceplate of the CRT must be at room temperature.

The monitor is equipped with an automatic degaussing circuit. However, if the CRT shadow mask has become excessively magnetized, it may be necessary to degauss it with manual coil. Do not switch the coil OFF while the raster shows any effect from the coil.

Purity Magnets are used for Color Purity and V Centering Adjustment.

Purity Adjustment procedure is as follows.

1. Remove R-G-B signal from monitor.
2. Turn Green Cut off Control (VR404) on the Neck Board fully CCW.
Turn Red and Blue Cut off Control (VR405) fully CW.
3. Pull the Deflection Yoke backward so that the Magenta belt will appear. (See Fig. 4)
4. Move the two Purity Magnets and bring the Magenta belt to the mechanical center of the screen (See Fig. 5) The vertical center position should be set VRS to $-5/64$ " (-2 mm) as shown in Fig. 6.
Insert service tip "N" on Neck circuit board to "S" on Vert./Horiz. circuit board (See Fig. 13). To check, use the Green raster at low intensity. Be sure to return the service tips to their original positions for the next check.
5. Push the Deflection Yoke forward gradually and fix it at the place where the Magenta screen becomes uniform throughout.
6. Turn Cut off Control, and Drive Control and confirm that each color is uniform.
7. If the color is not uniform, re-adjust it moving Purity Magnets slightly.
8. Move a pair of Purity Magnets at the same time (do not change the angle of the pair), and adjust the vert. center to center of screen.
9. Obtain the three colors and confirm whether white uniformity is balanced.
10. Insert the temporary wedge as shown in Fig. 5 and adjust the angle of Deflection Yoke.

STATIC CONVERGENCE ADJUSTMENT

A recently developed Deflection Yoke and Electron Guns construction has been used on this equipment in combination with In-Line Guns and Black Stripe Screen to make a barrel-type magnetic-field distribution for vertical deflection and a pin-cushion-type magnetic field for horizontal deflection with which a self-converging system can be obtained. This type is different from conventional unity-magnetic field distribution type deflection yoke. 4-Pole Magnets and 6-Pole Magnets are

employed for static convergence instead of a Convergence Yoke.

1. A cross hatch signal should be connected to the monitor.
2. A pair of 4-Pole Convergence Magnets are provided and adjusted to converge the blue and red beams. When the Pole opens to the left and right 45° symmetrically, the magnetic field maximizes. Red and blue beams move to the left and right oppositely (See Fig. 7-a and 7-b). Variation of the angle between the tabs adjusts the convergence of red and blue vertical lines.
When the both 4-Pole Convergence Magnet Tabs are rotated as a pair, the convergence of the red and blue horizontal lines is adjusted.
3. A pair of 6-Pole Convergence Magnets are also provided and adjusted to converge the magenta (red + blue) to green beams.
When the Pole opens to the left and right 30° symmetrically, the magnetic field is maximized. Red and blue beams both move to the left and right (See Fig. 8-c and 8-d).
Variation of the opening angle adjusts the convergence of magenta to green vertical lines. When both 6-Pole Convergence Magnet Tabs are rotated as a pair the convergence of magenta to green horizontal lines is adjusted.

PRECISE ADJUSTMENT OF DYNAMIC CONVERGENCE (See Fig. 10 and 11)

1. Feed a cross hatch signal to the monitor.
2. Insert the temporary wedge and fix Deflection Yoke so as to obtain the best circumference convergence (See Fig. 10 and 11).
NOTE:
The temporary wedges may need to be moved during adjustments.
4. Insert three rubber wedges to the position as shown in Fig. 9 to obtain the best circumference convergence.

NOTE:

- 1) Tilting the angle of the yoke up and down adjusts the crossover of both vertical and horizontal red and blue lines. See Fig. 10 (a) and (b).
- 2) Tilting the angle of the yoke sideways adjusts the parallel convergence of both horizontal and vertical lines at the edges of the screen. See Fig. 11-a and b.
- 3) Use three rubber wedges (thick and thin rubber wedges are used for a purpose).
- 4) The angle of each rubber wedges are shown in Fig. 9.
- 5) After three rubber wedges have been inserted, pull out the temporary wedge.
- 6) Fix the rubber wedges with chloroprene rubber adhesive.

INSTALLATION AND SERVICE INSTRUCTIONS

BLACK AND WHITE TRACKING (With R/G.B. inputs grounded)

1. Set Black Level Control (VR201) to mid point.
2. Set Red and Blue Drive Controls (VR401 & VR402) to their mechanical center.
3. Set the G2 Screen Control (VR406) and the 3 Cut-off Controls (VR403, VR404, & VR405) to minimum

(CCW).

4. Slowly turn up G2 screen control until the first faint color appears.
5. Slowly turn up the other two color cut-off controls in turn to match the first.
6. Remove ground from R/G/B inputs. Adjust Red and Blue Drive Controls (VR401 & VR402) for white screen.

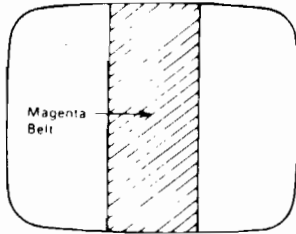

FIGURE 4

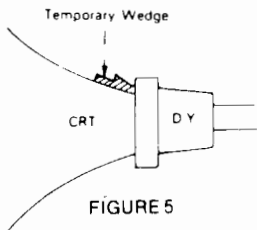

FIGURE 5

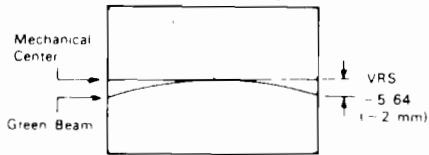
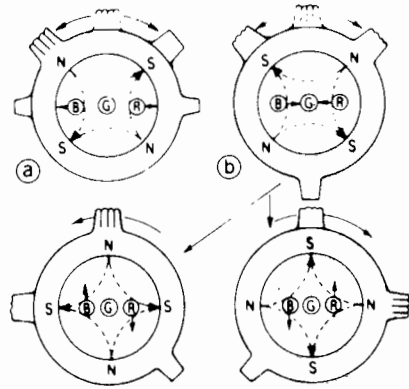
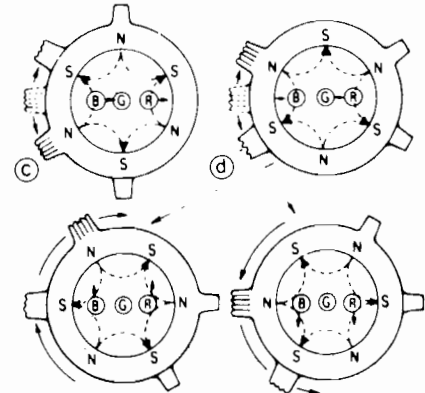

FIGURE 6



4-Pole Magnets and the Movement of Beams

FIGURE 7



6-Pole Magnets and the Movement of Beams

FIGURE 8

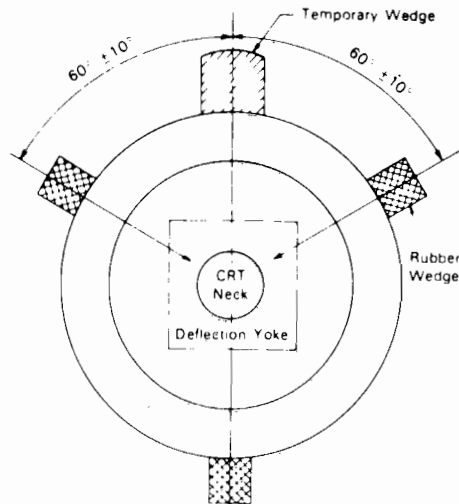
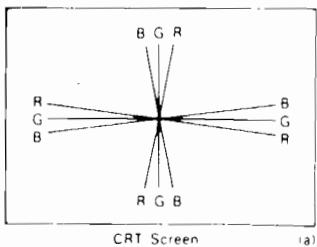
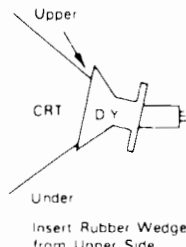

FIGURE 9



CRT Screen

(a)



Insert Rubber Wedge from Upper Side

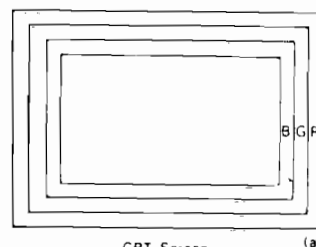

CRT Screen

(a)

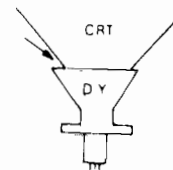

Insert Rubber Wedge from Left Side

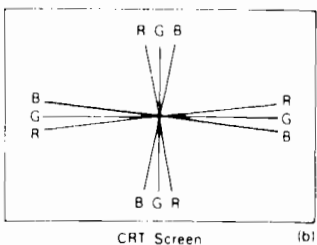

CRT Screen

(b)

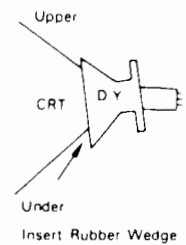

Insert Rubber Wedge from Lower Side

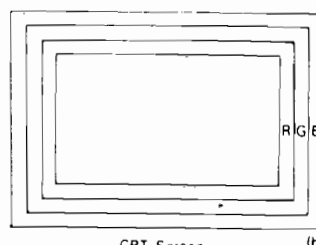

CRT Screen

(b)

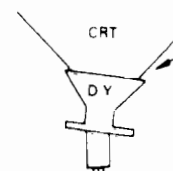

Insert Rubber Wedge from Lower Side

FIGURE 11

FIGURE 10

ELECTROHOME MONITOR - GENERAL INSTRUCTIONS Service Set-Up Procedure

NOTE: All monitors are equipped with automatic degaussing coils which effectively demagnetize the picture tube each time the monitor is turned on. The degaussing coils will operate any time the set is turned on after having been off for at least five minutes.

The degaussing effect is confined to the picture tube since the coils are mounted on the ferrous tube shield. Should any part of the chassis or cabinet become magnetized, it will be necessary to degauss the affected area by means of a manual degaussing coil. Move the coil slowly around the CRT face area, then slowly withdraw for a distance of six feet before disconnecting the coil from the AC power supply.

Normally little, if any adjustment should be necessary. However, when a picture tube, yoke or similar component is replaced, preliminary static convergence should be done before attempting purity adjustment, and so on.

Set up should be done in a north/south direction. Horizontal and vertical centering taps should be set to the centre position if a major component has been changed.

1.0 Purity

1.1 Loosen yoke retaining clamp (figure 2), remove adhesive material fixing wedges to CRT. Remove wedges completely and clean off dried adhesive from picture tube and wedges.

1.2 A small quantity of "nail polish" has been used to lock the purity convergence rings in place. This seal must be broken with a sharp tipped instrument before any adjustments are attempted. Some models also use a locking ring at either end of the purity and convergence rings. This must be loosened before adjustments are made. It goes without saying that upon completion of all adjustments, the lock must be reset and/or a dab of paint or nail polish must be re-applied to edge of rings to prevent movement.

1.3 Connect an appropriate signal source, eg: Electro-home RGB generator producing a white field plus individual red, green and blue fields.

1.4 Bring the long and short purity tab protrusions in line with each other to obtain near-zero magnetic field (figure 4) (In some cases bring the flat and indented tabs together to obtain zero field). Protrusions can then be vertical, horizontal or at any convenient angle to start.

1.5 Turn off the green and blue fields and adjust setup controls to produce a red field. (See fig. 3)

1.6 Pull the deflection yoke back so that a red band appears in the centre of the screen.

1.7 Spread the tabs apart as little as necessary and rotate both rings together to center the red band horizontally on the face of the CRT (approximate). (See Fig. 5)

1.8 Slide the yoke towards the bell of the picture tube slowly to obtain a uniform red field (pure in color) across the entire tube face. Juggle back and forth slightly as necessary. Lightly tighten yoke retaining clamp.

1.9 Momentarily switch on a cross-hatch signal and rotate yoke to level the pattern on the face of CRT.

1.10 Return generator to regain red raster.

1.11 Turn off red field and check for pure field for each of the green and blue fields. Reposition yoke if necessary to obtain optimum purity on all fields.

1.12 Tighten yoke retaining clamp to prevent yoke shift or rotation. (Do not install wedges at this time.)

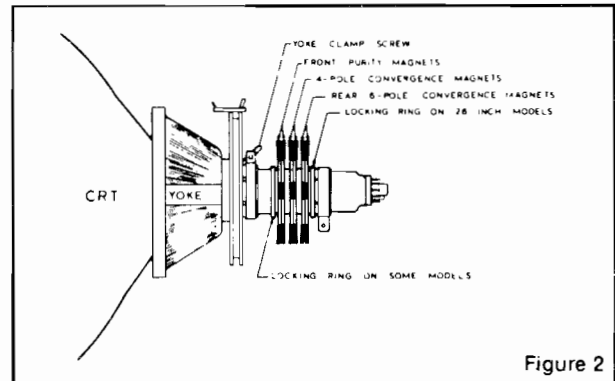

Figure 2

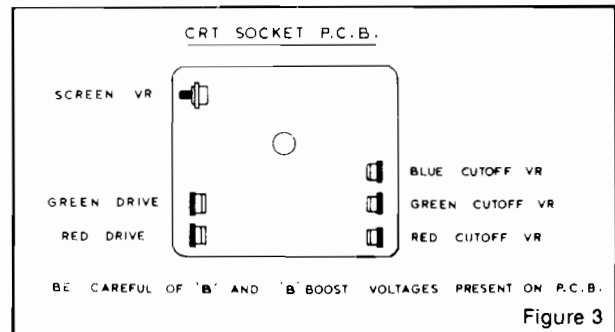

Figure 3

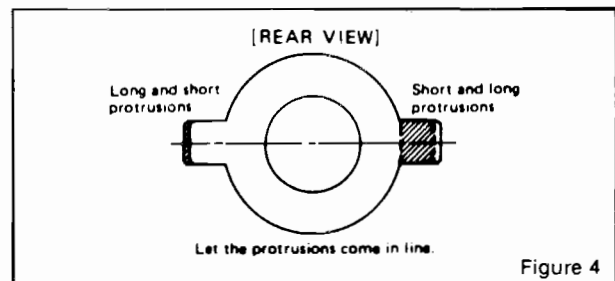

Figure 4

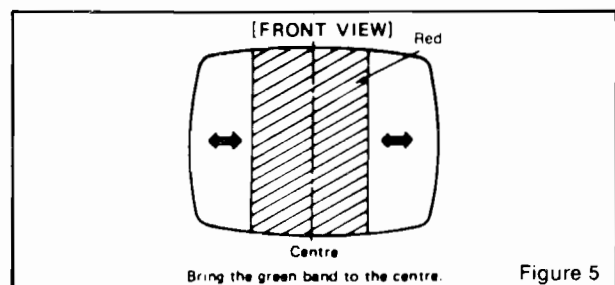

Figure 5

2.0 Static and Dynamic Convergence

NOTE: Static convergence is achieved by four magnets located on the neck, nearest the base of the picture tube, Fig. 2. The middle pair of magnetic rings are adjusted to converge the blue and red crosshatch lines. The rear pair of convergence rings (closest to the base of the picture tube) are adjusted to converge the magenta (blue/red) to the green crosshatch lines. Dynamic convergence is achieved by tilting the deflection yoke up-down and left-right.

- 2.1 Ensure that the controls misadjusted during purity setup (screen, cut-off, etc.) are set to give white balance. See 3.0 below.
- 2.2 Switch generator to the crosshatch pattern.
- 2.3 Adjust convergence around the edges of the picture tube by tilting the yoke up-down and left-right, and temporarily install one wedge at the top of the yoke or in a more optimum position. (Figures 8, 9, 10)
- 2.4 Turn off green input and turn on the red and blue input.
- 2.5 Rotate the 4-pole (middle) pair of magnets as a unit to minimize separation of the red and blue crosshatch lines around the center of the screen (Figure 6). Variation of the angle between the tabs adjusts convergence of red and blue. (Tilt yoke as required to converge red and blue at the edges as in 2.3 above.)
- 2.6 Turn on green input to obtain magenta (red/blue) and green crosshatch lines. Rotate the 6-pole (rear) pair of magnets as a unit to minimize separation of the magenta and green lines (figure 7). Vary angle between the two tabs and further rotate as a unit to finalize.
- 2.7 When convergence of 3 colors is optimized (static in center and dynamic around edges) apply stripe of paint or nail polish to convergence magnet rings to prevent movement. If applicable, tighten locking ring carefully.
- 2.8 Remove temporary wedge from yoke. Tilt yoke in up-down and left-right direction for best circumference convergence and install 3 wedges. (It is best to use 3 new wedges since they have adhesive backing. Simply pull off tape, slide wedge in place and press outer flap down firmly. For more permanency apply small quantity of silastic or similar material at junction of wedges and picture tube. Do not disturb while material is setting. (Order wedges by part number 39-1233-01).

3.0 White Balance (Grey Scale Tracking)

Refer to figure 3. Do the following in subdued light:

- 3.1 Note this adjustment can be accomplished with no signal connected; eg: input connector open or if a signal generator is connected, switch off all 3 inputs at the generator.
- 3.2 Set red and green drive controls to their mechanical center and turn the common G2 screen control and 3 cut-off controls to minimum (fully counterclockwise).
- 3.3 Slowly turn up G2 screen control until the first faint color appears, then back off to edge of visibility. Do not touch the associated cut-off control - it should stay fully CCW for the remaining set-up.
- 3.4 Slowly turn up the other two color cut-off controls in turn to match the first. This should result in the faintest grey.
- 3.5 Turn on the signal generator with all 3 inputs on. (a crosshatch pattern would be appropriate).

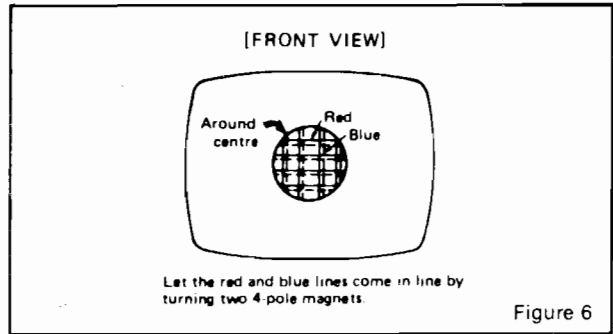

Figure 6

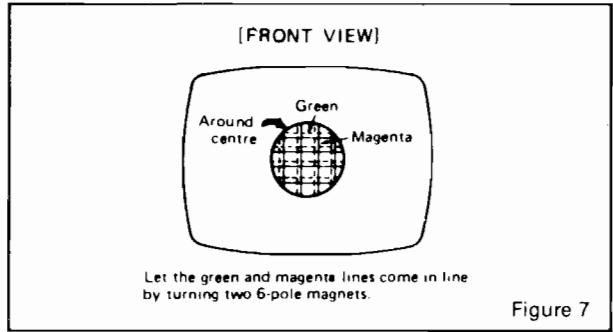

Figure 7

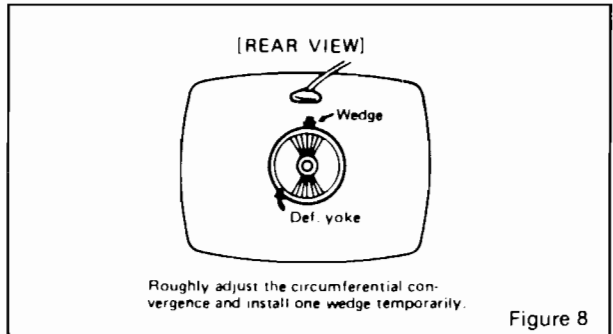

Figure 8

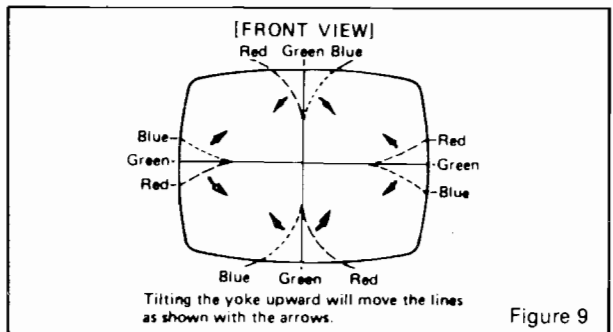

Figure 9

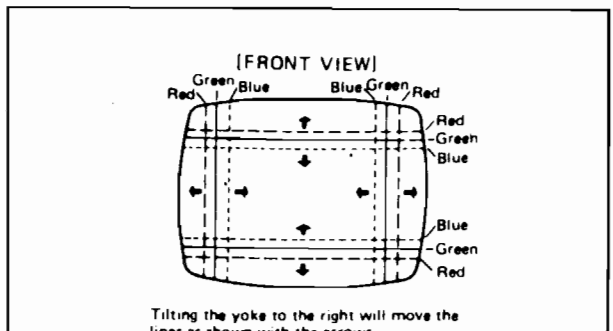
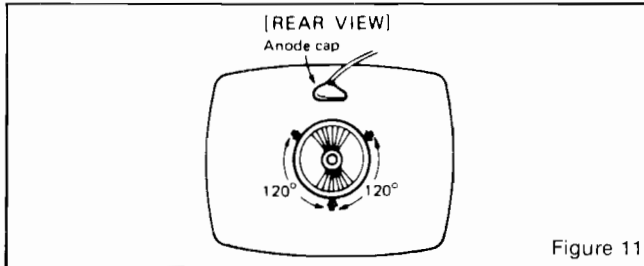

Figure 10

- 3.6 Adjust the red and green drive controls for "neutral white" on high white picture areas. Generally these controls will be left at mech. centre.
- 3.7 Note: When monitor is re-connected with the game the screen control (G2) may require a slight adjustment to obtain proper black level. (the black portion of picture just extinguished).



4.0 Power Supply

The regulated +B1 control (R909) has been factory adjusted and normally requires no adjustment. However, if any repairs have been made to the chassis it is recommended that this adjustment should be made.

- Allow 5 minutes to warm up.
- No signal applied.
- Connect an accurate D.C. voltmeter to TP-91 or the emitter of X04 power regulator transistor.
- Adjust R909 for 120V. (See fig. 1)

Note:

Should +B1 control be set too high, it may cause possible component damage. Use an accurate D.C. voltmeter to set B1 (B+).

5.0 Focus

Adjust focus control for best overall definition and picture detail an average signal applied. (Highlights should be favoured.)

6.0 Color Service Generator for G07 Monitor

Electrohome has developed a color service generator that is specifically designed for use with the G07 color data monitor. It provides the monitor with both horizontal and vertical sync, as well as the following test patterns:

- Fine cross-hatch pattern
- Broad bar cross-hatch pattern
- Complete field

Three color selection switches, red, green and blue, provide the ability to display the above patterns in the three primary colors as well as the three secondary colors.

This product may be ordered from:

Contracts Marketing
ELECTROHOME Electronics
809 Wellington St. North
Kitchener, Ontario
Canada N2G 4J6
Telephone: (519) 744-7111, Ext. 567



7.0 X-Ray Emission Check

- Assure the power supply B1 is properly adjusted to 120V DC. See Item 4.0 (page 8)
- Assure that the anode voltage does not exceed max. as per Item 2.0 page 4.
- Assure that the high voltage hold down circuit is operating correctly. Use the following procedure.
 - Increase the B1 greater than 138.5V by shorting collector/emitter of the power regulator, X04.
 - Observe that the anode voltage (EHT) goes to 0. If the EHT does not go to 0, a fault must be located and repaired.
 - Remove short and set should return to normal operation. (Note, after the short is removed some monitors may not restart. In this case, remove power from monitor momentarily and normal operation will be restored.

Note:

The protector circuit consists of the components shown below in Fig. 13 with a circuit description.

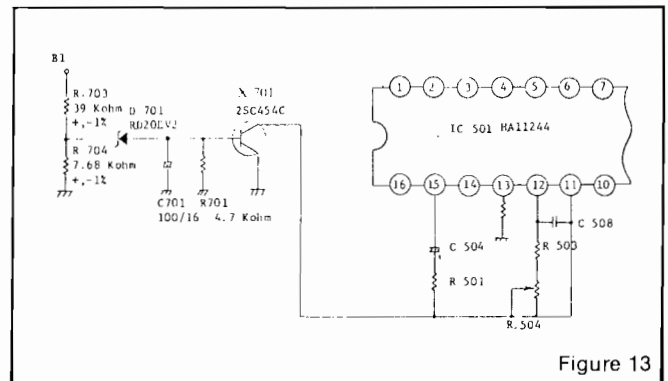

8.0 Circuit Diagram and Description of High Voltage Hold Down or Safety Circuit

- Circuit Diagram of High Voltage Hold Down Circuit.
- Operation of High Voltage Hold Down Circuit.

The high voltage hold-down circuit protects the high voltage circuit from dangerous voltage with short circuiting between emitter and collector of power regulating transistor.

The base voltage of X701 is increased when the B1 voltage is increased more than 138.5 V DC.

When the base of X701 is increased, a short is produced by X701 between pin 11 and ground of IC 501, shutting down the horizontal osc. and high voltage.

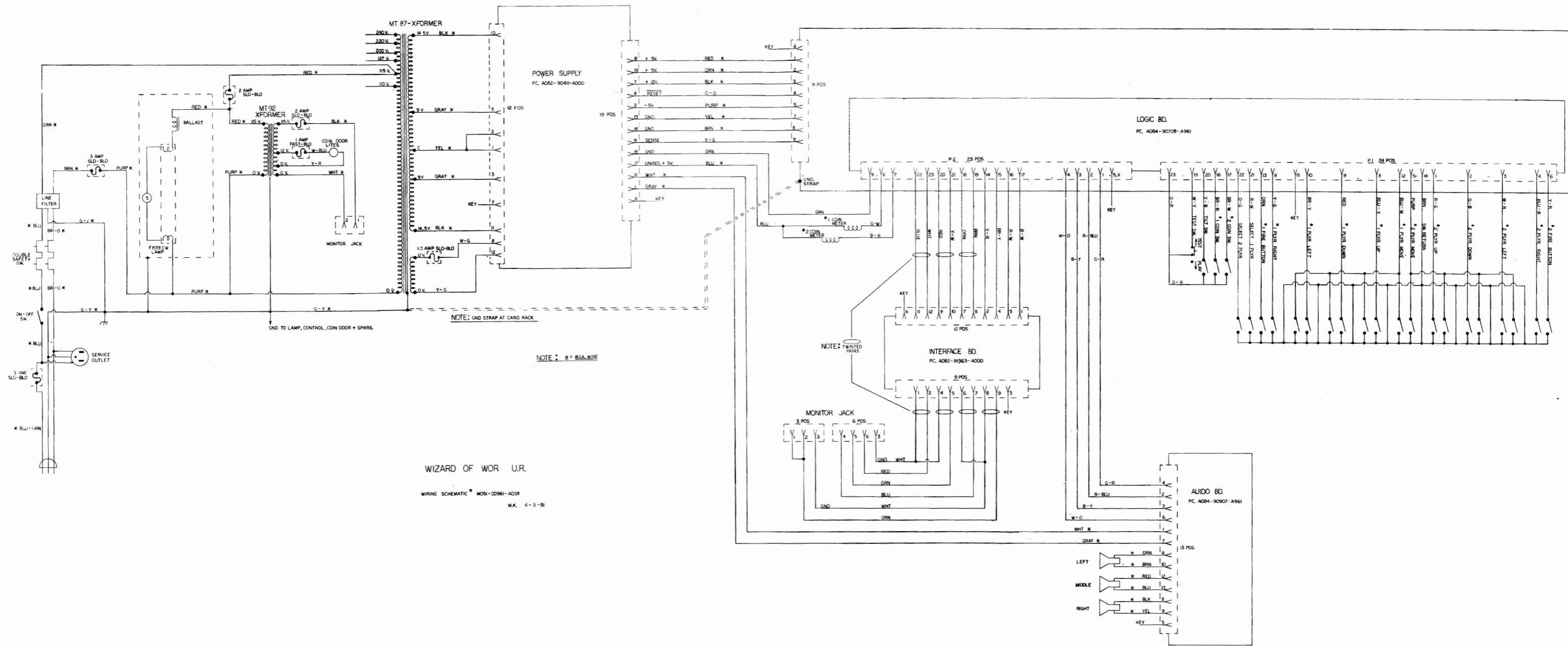

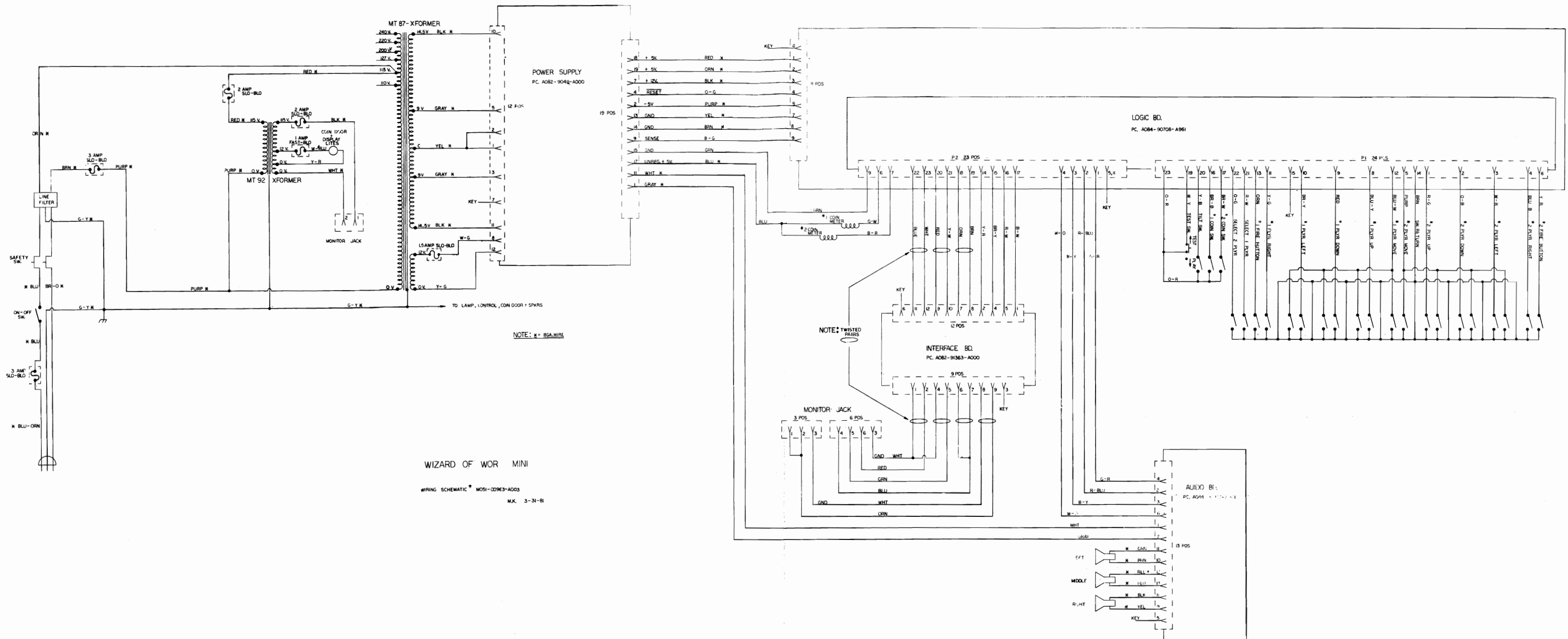

COMPONENT NO.

A14F
 A15E
 IN4004
 2N3055
 LM317
 79M05
 LM339
 SG3532
 470 UF, 16V.
 4,700 UF, 25V.
 10,000 UF, 35VDC
 20,000 UF, 16VDC
 20,000 UF, 35VDC

MIDWAY PART NO.

0064-168XX-XXGX
 0064-169XX-XXGX
 0064-030XX-XXCP
 0065-085XX-XXGX
 0066-004BX-XXAX
 0066-801AX-XXCX
 0066-020BX-XXCX
 0066-044BX-XXGX
 0061-271DX-5FGX
 0061-314EX-5E2X
 0061-322GX-5E2X
 0061-326DX-5E2X
 0061-300GX-5E2X

QUANTITY

(3 PER.)
 (6 PER.)
 (4 PER.)

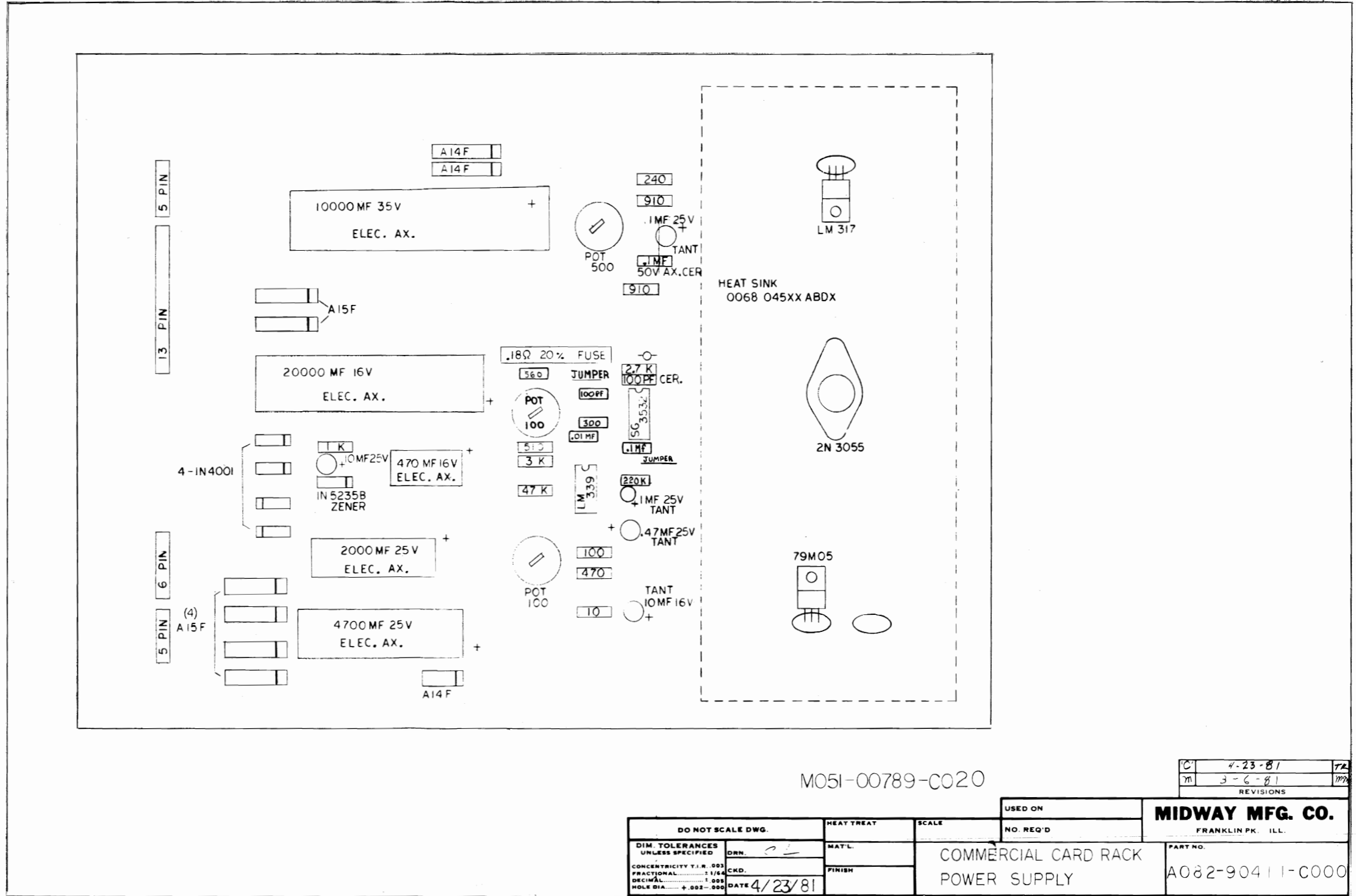

M051-00789-C020

4-23-81	TZ
3-6-81	777
REVISIONS	

DO NOT SCALE DWG.		HEAT TREAT	SCALE	USED ON	MIDWAY MFG. CO. FRANKLIN PK. ILL.
DIM. TOLERANCES UNLESS SPECIFIED		MAT'L.	NO. REQ'D		
DRN. PL	CONCENTRICITY T.I.R. .003	FINISH	COMMERCIAL CARD RACK POWER SUPPLY		PART NO.
DATE 4/23/81	FRACTIONAL 1/64				A082-90411-C000
	DECIMAL 1.000				
	HOLE DIA. 4.000- .005				

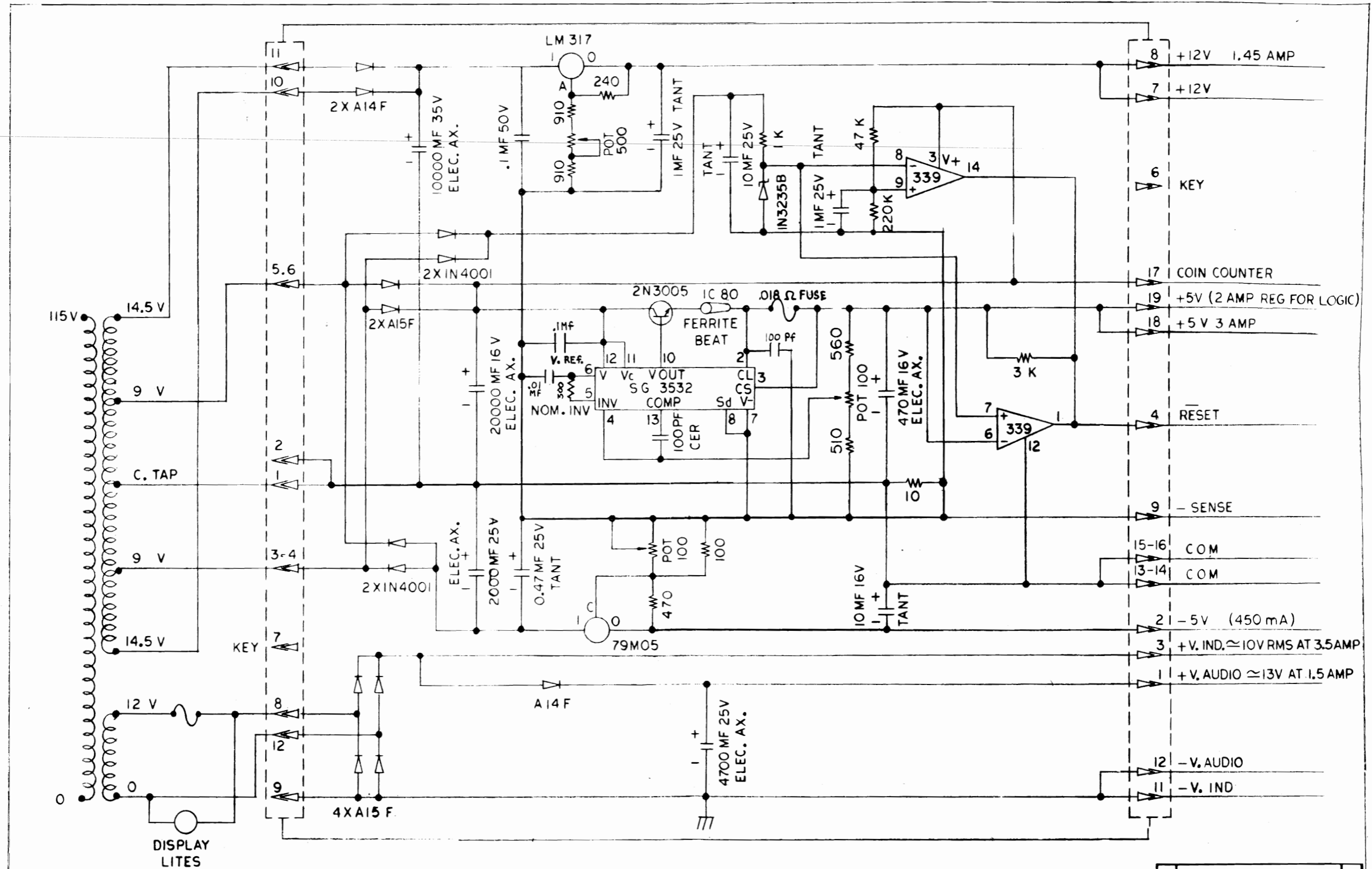

DRAWING NO. M051-00789-C011

REV	4-23-81	TK
REVISIONS		

DO NOT SCALE DWG.		HEAT TREAT	SCALE	USED ON	MIDWAY MFG. CO. FRANKLIN PK. ILL.
DIM. TOLERANCES UNLESS SPECIFIED		MAT'L	NO. REQ'D	PART NO.	
CONCENTRICITY T.I.R. .003	DRN. CA			COMMERCIAL CARD RACK	A082-90411-C000
FRACTIONAL .1/64	CKD.			PWR SPLY SCHEMATIC	
DECIMAL .005	DATE 4/23/81	FINISH			
HOLE DIA. +.002-.006					

VII. SCHEMATICS AND WIRING DIAGRAMS

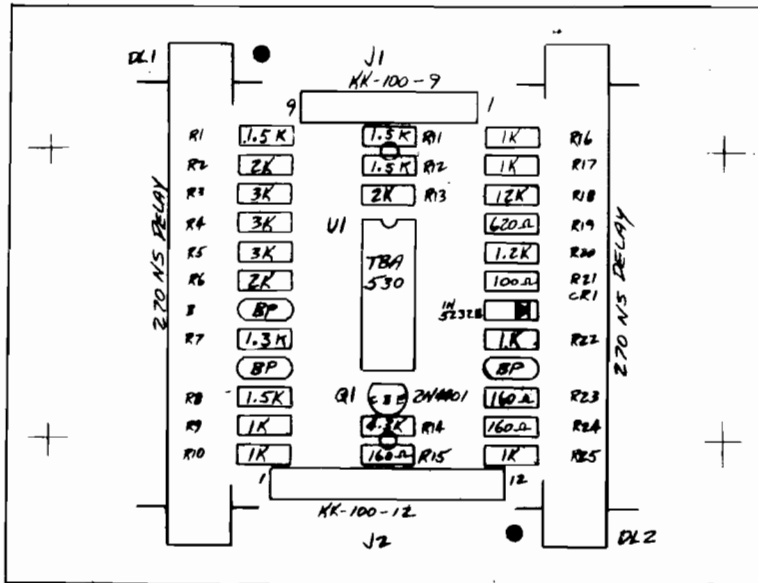

M051-00873-B029		<table border="1"> <tr> <td>B. MFG. 3/15/58</td> <td>5-1-58</td> </tr> <tr> <td>COMP. CHANGES</td> <td>1-5-58</td> </tr> <tr> <td>REV. FOR PROJ</td> <td>9/15/58</td> </tr> </table>		B. MFG. 3/15/58	5-1-58	COMP. CHANGES	1-5-58	REV. FOR PROJ	9/15/58																		
B. MFG. 3/15/58	5-1-58																										
COMP. CHANGES	1-5-58																										
REV. FOR PROJ	9/15/58																										
DO NOT SCALE DIMS.		NO. REQ'D																									
USED ON		MIDWAY MFG. CO. <small>FRANKLIN PARK, ILL. 60131</small>																									
<table border="1"> <tr> <td>DIM. TOLERANCES UNLESS SPECIFIED</td> <td>DRK.</td> <td>SCALE</td> <td>MATL.</td> </tr> <tr> <td>CONCENTRICITY T.I.R. .008</td> <td>CKD</td> <td>HEAT TREAT</td> <td>FINISH</td> </tr> <tr> <td>FRACTIONAL .2 1/64</td> <td>DATE</td> <td></td> <td></td> </tr> <tr> <td>DECIMAL .2 .008</td> <td></td> <td></td> <td></td> </tr> <tr> <td>HOLE DIA. +.008 -.000</td> <td></td> <td></td> <td></td> </tr> </table>		DIM. TOLERANCES UNLESS SPECIFIED	DRK.	SCALE	MATL.	CONCENTRICITY T.I.R. .008	CKD	HEAT TREAT	FINISH	FRACTIONAL .2 1/64	DATE			DECIMAL .2 .008				HOLE DIA. +.008 -.000				<table border="1"> <tr> <td colspan="2"> <i>RGB INTERFACE</i> <i>COMM. CARD RACK</i> </td> <td colspan="2"> PART NO A082-91363-8000 </td> </tr> </table>		<i>RGB INTERFACE</i> <i>COMM. CARD RACK</i>		PART NO A082-91363-8000	
DIM. TOLERANCES UNLESS SPECIFIED	DRK.	SCALE	MATL.																								
CONCENTRICITY T.I.R. .008	CKD	HEAT TREAT	FINISH																								
FRACTIONAL .2 1/64	DATE																										
DECIMAL .2 .008																											
HOLE DIA. +.008 -.000																											
<i>RGB INTERFACE</i> <i>COMM. CARD RACK</i>		PART NO A082-91363-8000																									

COMPONENT DESIGNATION

COMPONENT NO.

MIDWAY PART NO.

(U1)
 (DL1-DL2)
 (Q1)

TBA530
 270NS DELAY
 2N4401

0066-033XX-XX9X
 0069-166XX-XAMX
 0065-213XX-XXCX

TBA-530

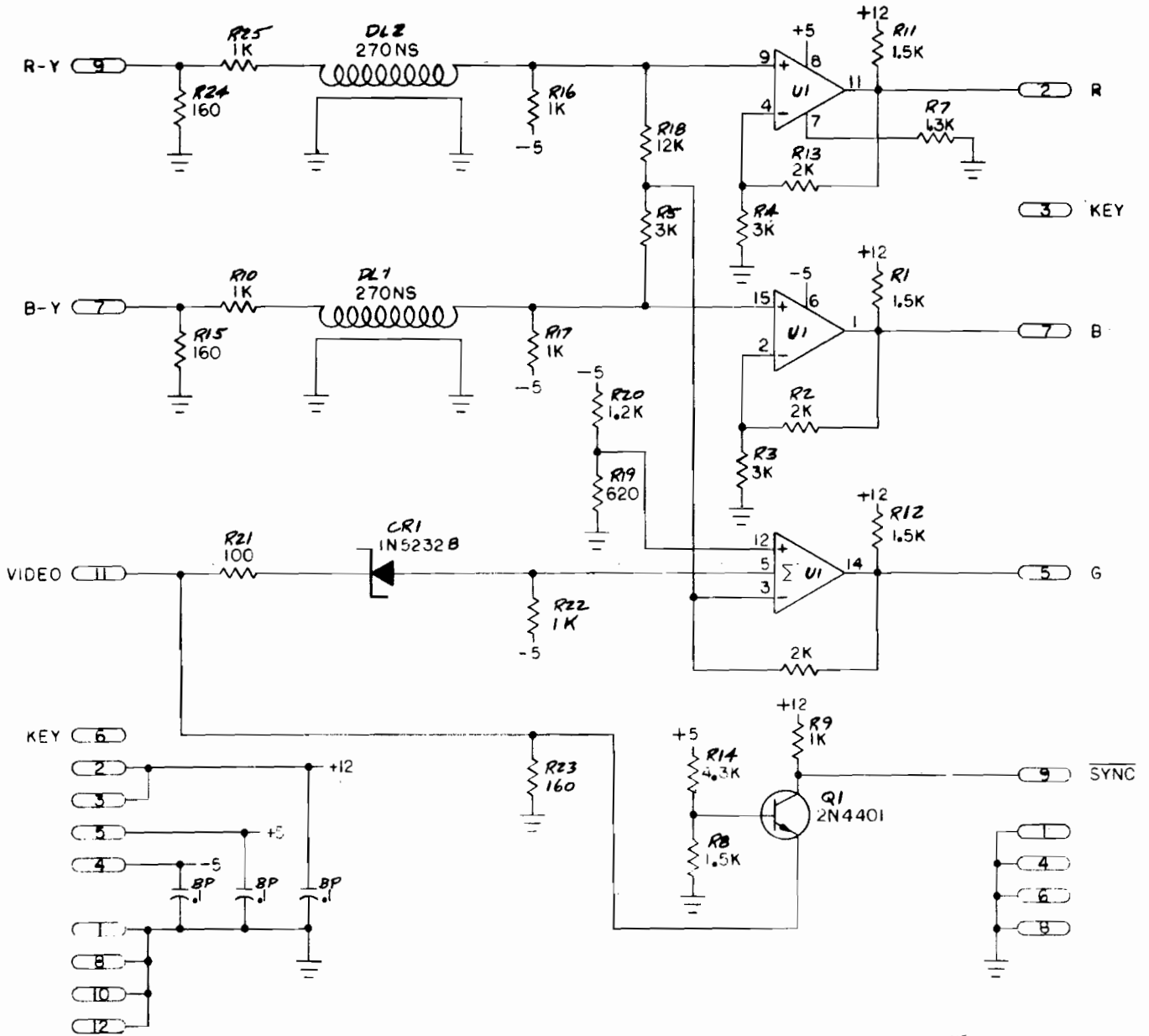

M051-00873-B030

		SCALE	DATE	DRAWN BY	MIDWAY MFG. CO
		NONE	8-29-80	OTTO	
		MATERIAL		FINISH	TITLE
					RGB INTERFACE
B MECH CHG 5/1-81					FOR CCRS
COMP CHANGES 1-5-81		TOLERANCES			NO
REL FOR PROD 9/24/80		AS - 01			A082-91363-0000
		XXX - 005			
		MODULAR 1			

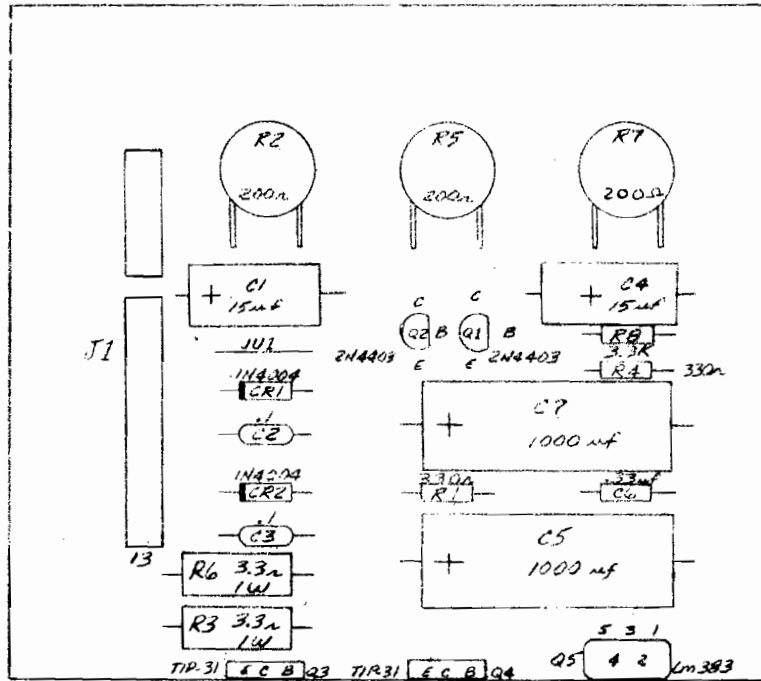

COMPONENT SIDE

M051-00961-A026

SCALE	DATE	DRAWN BY	MIDWAY MFG. CO.
1/2	3/7/81	JAT	
MATERIAL	FINISH	TITLE	AUDIO AMP #2
TOLERANCES			FOR
.XX - .01 .XXX - .000 ANGULAR :			531 42 LM383
A. REL. TO PROD.	5-1-81		A084-70907-A761

COMPONENT DESIGN

(CR1-CR2)
 (Q1-Q2)
 (Q3-Q4)
 (Q5)

COMPONENT NO.

IN4004
 2N4403
 TIP-31
 LM383

MIDWAY PART NO.

0064-030XX-XXCP
 0065-215XX-XXGX
 0065-485XX-XXQX
 0066-043DX-XXAX

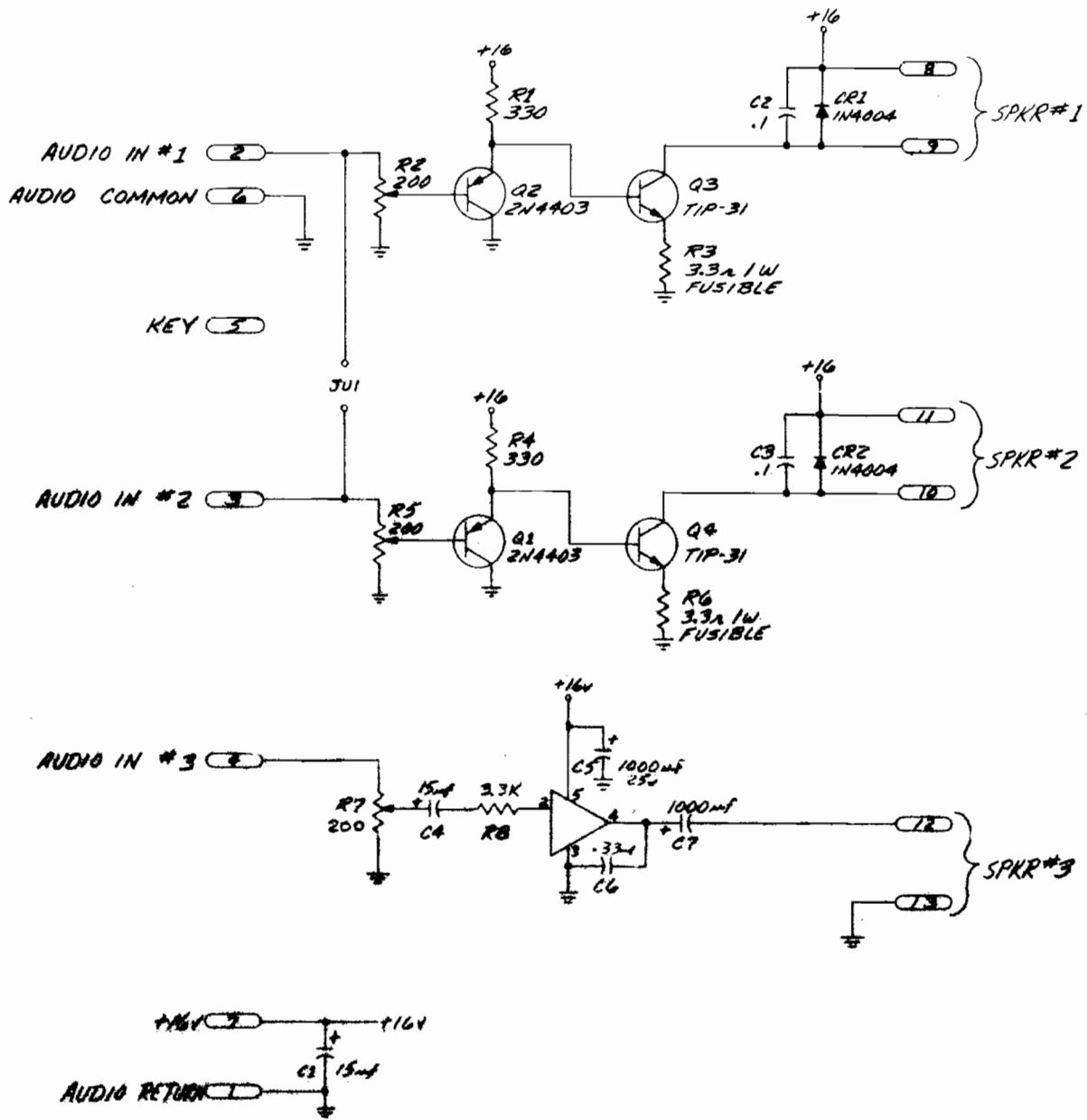

M051-00961-A027

SCALE	—	DATE	1/14/61	DRAWN BY	JAT	MIDWAY MFG. CO.
MATERIAL						AUDIO AMP 2
REV. TO PROD	5-1-61					100-90907-A961

COMPONENT DESIGNATION	COMPONENT NO.	MIDWAY PART NO.
(U1-U16)	14027-3	0066-228XE-XXDX
(U17-U20)	74LS166	0066-206AX-XXCX
(U18-U19)	74LS253	0066-583AX-XXCX
(U21-U22)	7414	0066-520XX-XXAX

RAM BOARD
 A082-91356-C000
 M051-00789-C001

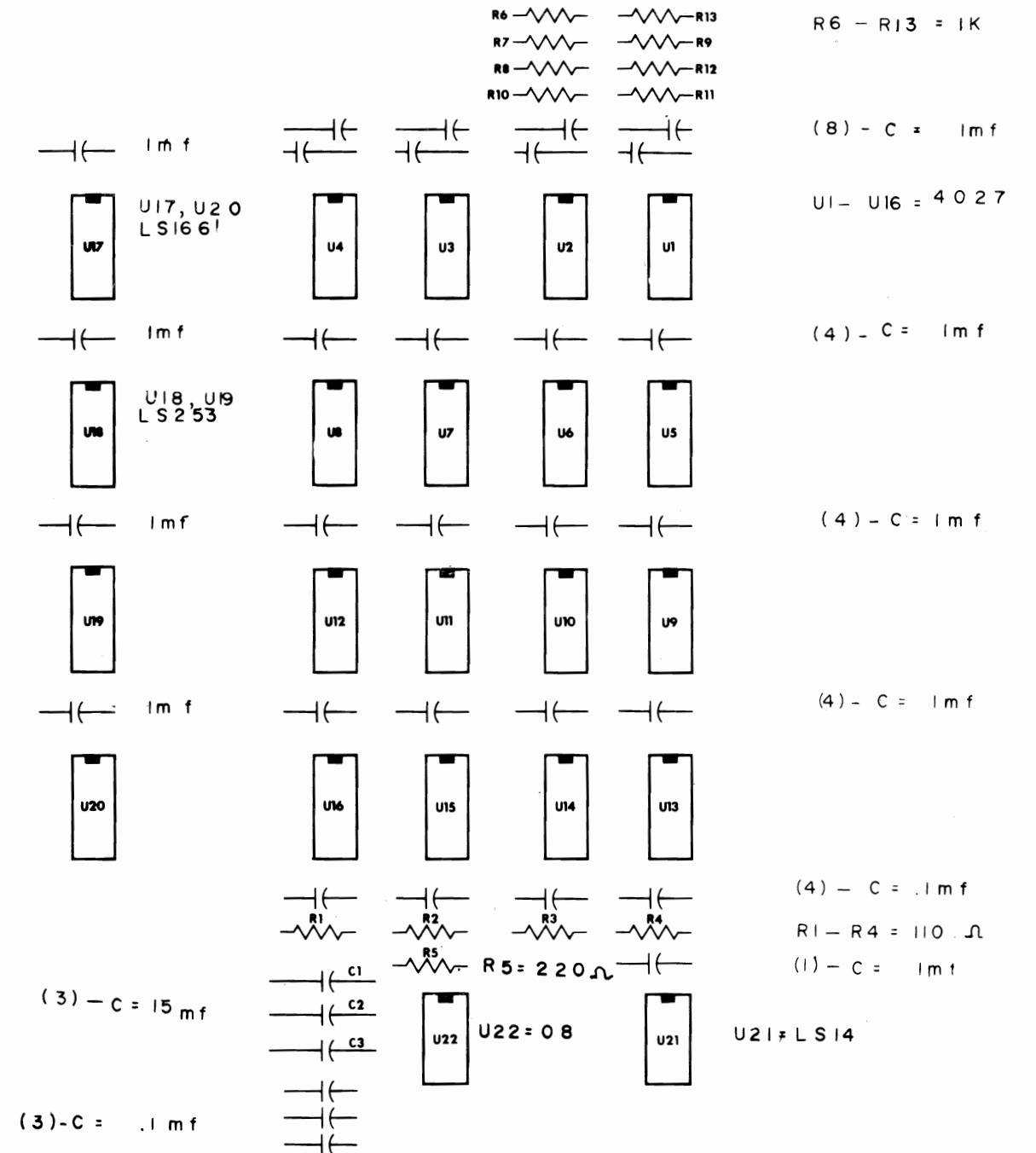

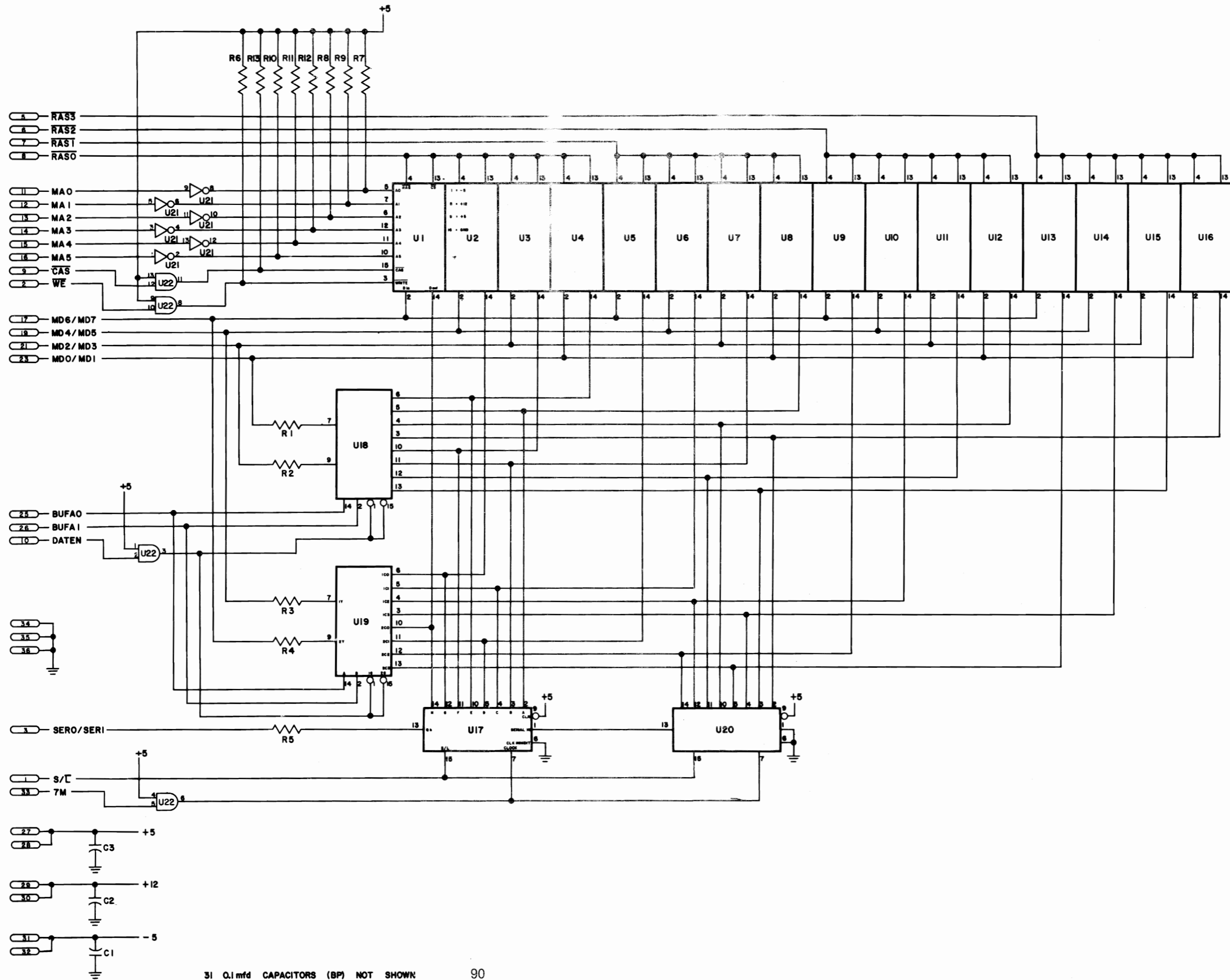

31 0.1mfd CAPACITORS (BP) NOT SHOWN

A082-91356-C000
M051-00789-C002

RAM BOARD

COMPONENT DESIGNATION

U1
U2
U3
U4
U5
U6, U20
U7
U8, U19
U9
U10
U11
U12, U16
U13
U14
U15
U17
U18
U21
Y1

CPU BOARD

COMPONENT NO.

74LS20
74LS174
CUSTOM ADDRESS
7416
74S74
74LS04
74LS10
74LS175
74LS08
74LS74
7402
74LS257
74LS157
74LS00
CUSTOM DATA
Z80
14024
74LS245
14,318 MHZ CRYSTAL

MIDWAY PART NO.

0066-553XX-XXCX
0066-243AX-XXBX
0066-115XX-XXYX
0066-530XX-XXCX
0066-821XX-XXCX
0066-473XX-XXAX
0066-502XX-XXBX
0066-248AX-XXCX
0066-493XX-XXCX
0066-823XX-XXCX
0066-460XX-XXCX
0066-643AX-XXDX
0066-161AX-XXBX
0066-453XX-XXAX
0066-118XX-XXYX
0066-124BX-XX2X
0066-100BX-XXDX
0066-468AX-XXCX
0069-035XX-XXKX

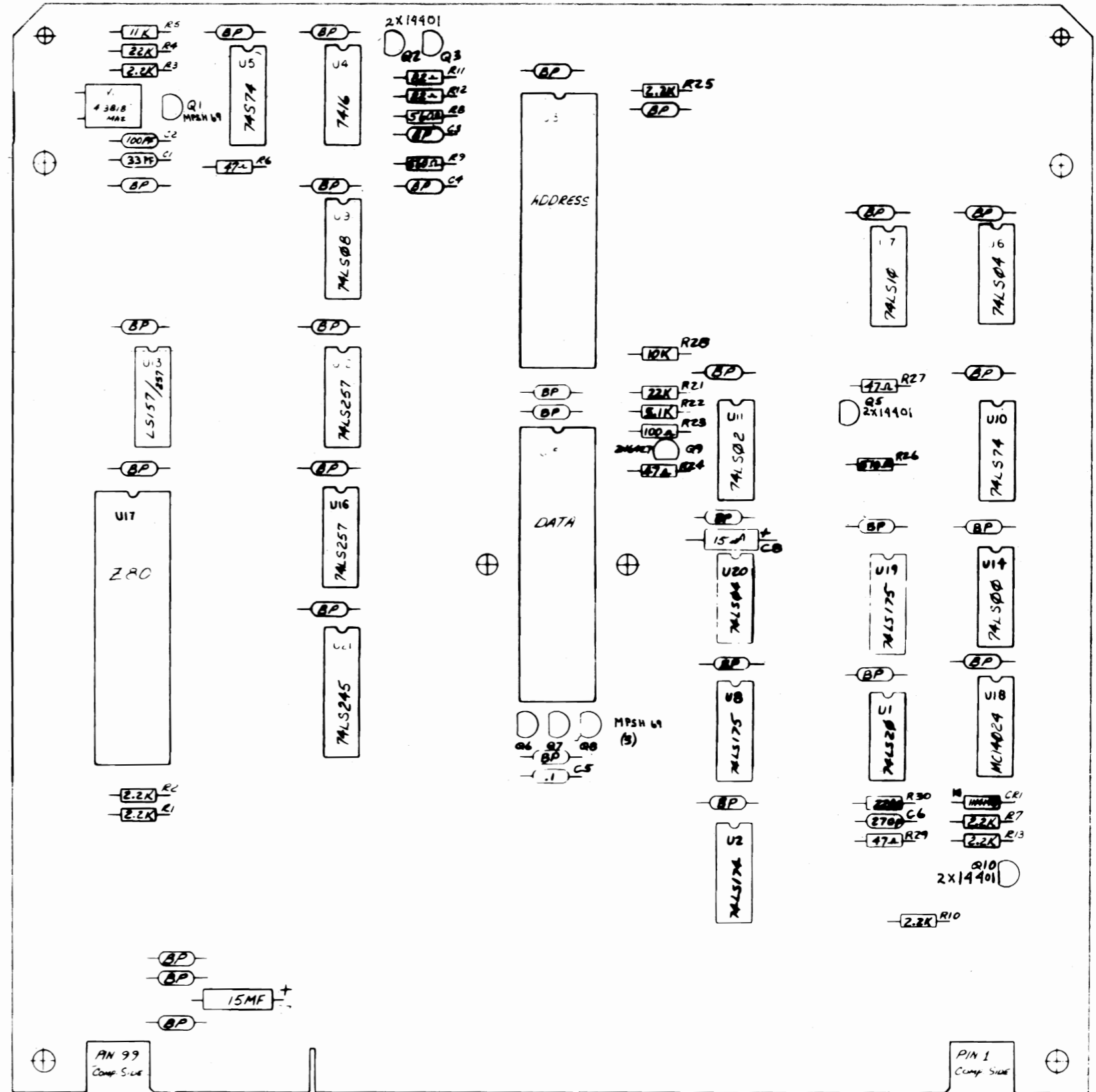

Component Side

M051-00789-F006

REV	DATE	BY	CHKD	QTY	DESCRIPTION
C	3-12-80	2:1	9-75	REF	MIDWAY MFG. CO.
D	6-12-80				CPU BOARD
E	7-15-80				CommCard Rack
					A0B2-91354-F000

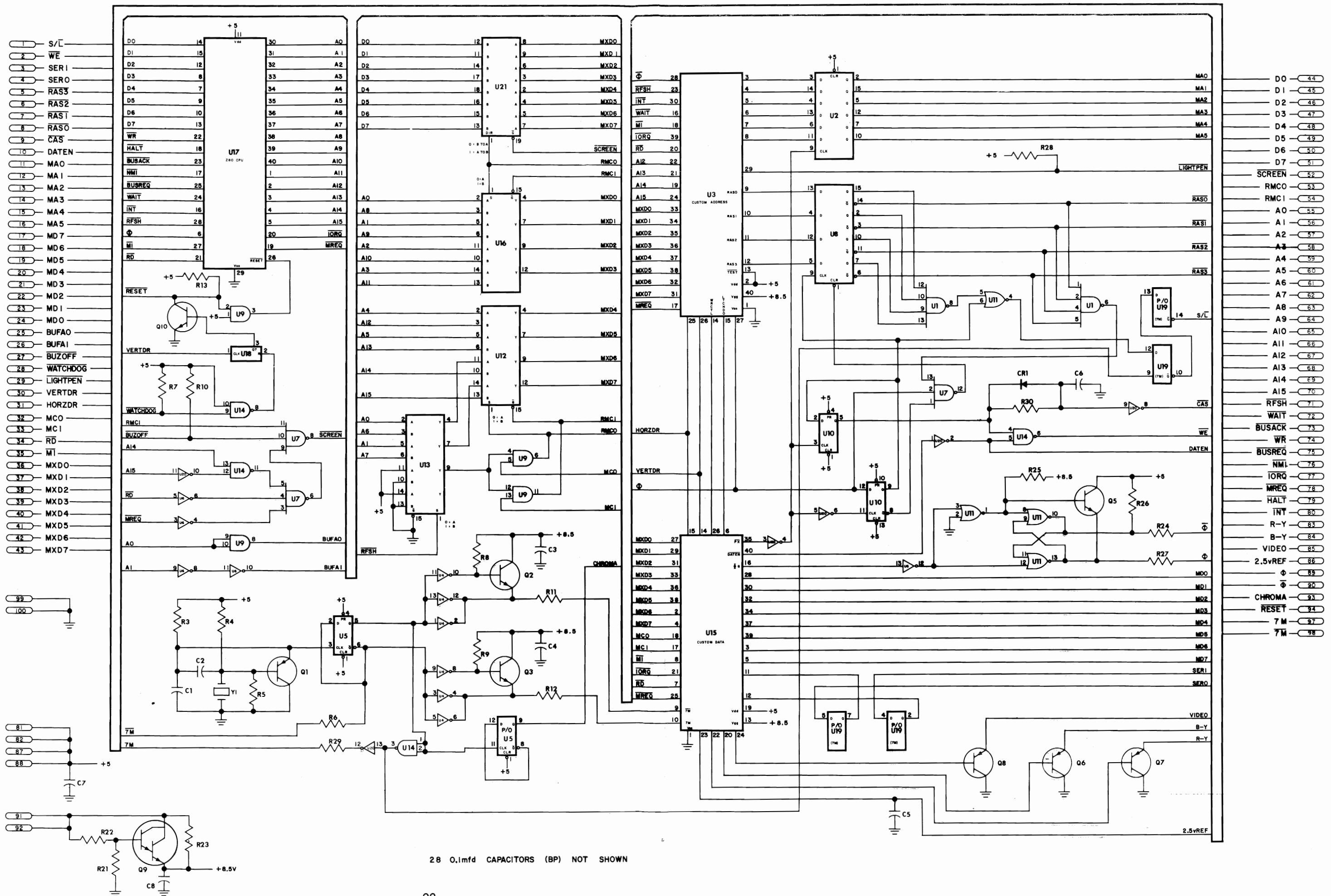

28 0.1mfd CAPACITORS (BP) NOT SHOWN

COMPONENT DESIGNATION

(U1-U2)
 (U3, U14)
 (U7, U9, U16, U18, U25, U27,
 U31, U33, U34, U36, U40, U42)
 (U15)
 (U21)
 (U23)
 (U24)
 (U28, U30, U32, U37, U39, U41)
 (U29, U38)
 (U6, U43)
 (U5)
 (U10, U19, U22)
 (U12)
 (U13)
 (U11, U20)
 (U8, U17, U26, U35)
 (U4)

COMPONENT NO.

14068
 14572
 14516
 14013
 14174
 14539
 14081
 14175
 14008
 74LS04
 74LS161
 74LS175
 74LS00
 74LS74
 74LS367
 74LS257
 14555

MIDWAY PART NO.

0066-277XX-XXDX
 0066-339XX-XXDX
 0066-331XX-XXDX
 0066-214XX-XXDX
 0066-320XX-XXDX
 0066-336XX-XXDX
 0066-304XX-XXDX
 0066-322XX-XXDX
 0066-209XX-XXDX
 0066-473XX-XXAX
 0066-183AX-XXHX
 0066-248AX-XXCX
 0066-453XX-XXAX
 0066-823XX-XXCX
 0066-700AX-XXBX
 0066-643AX-XXDX
 0066-091BX-XXEX

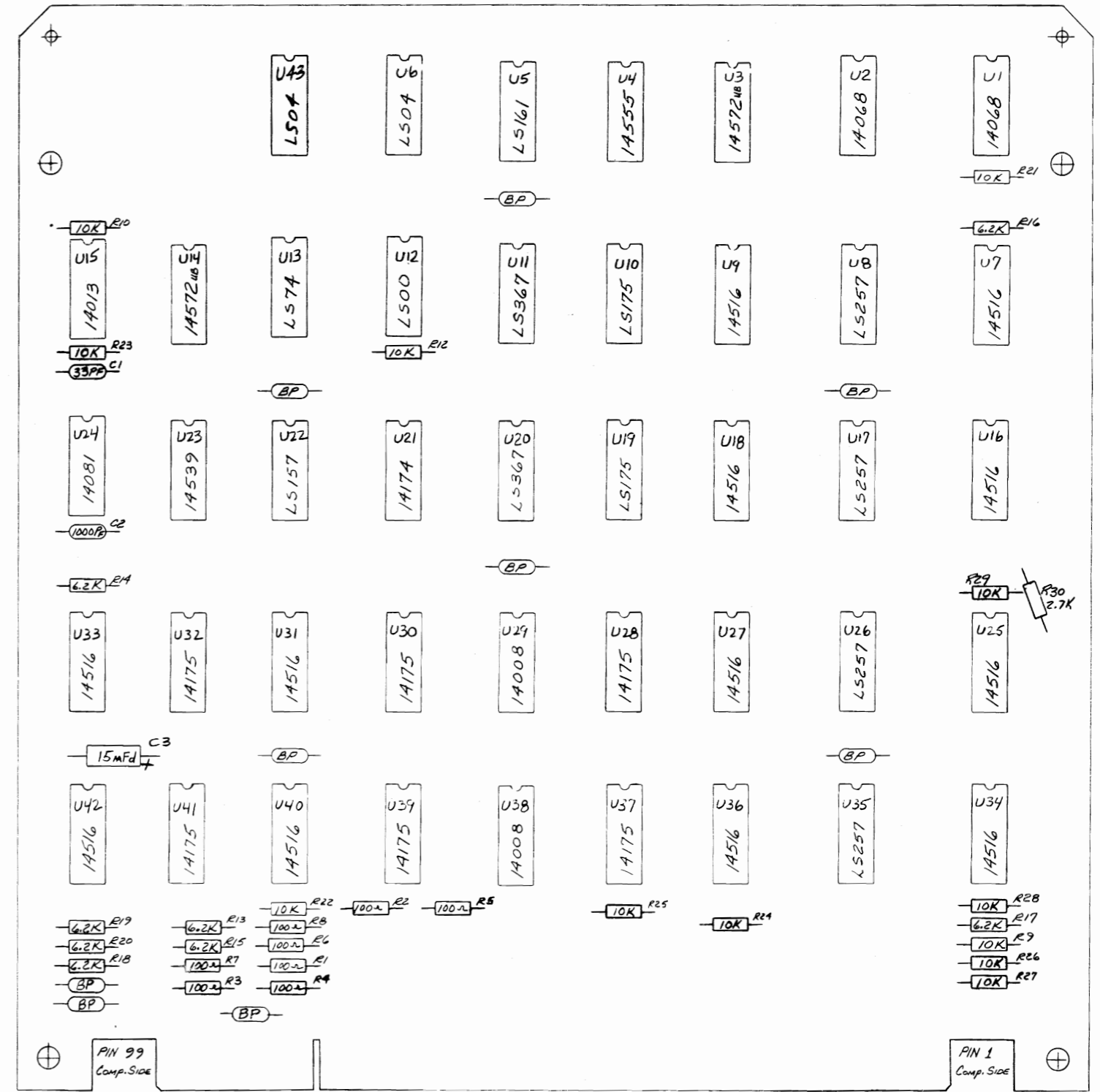

COMPONENT SIDE
 A082-91355-C000
 PATTERN BOARD
 COMM. CARD RACK

M051-00789-C015

REF. DES. CHANGED	3-10-80	SCALE	DATE	DRAWN BY	MIDWAY MFG. CO.
B	NET CHANGED	3-12-80	8:1	7/79	900K
C	U43 REVERSED MOVED, REWIRING	6-13-80	MATERIAL	FINISH	TITLE
C	E30 Added	1980			PATTERN BOARD
			TOLERANCES		FOR
			XXX-1.008		COMM. CARD RACK
			ANGULAR ±		NO
					A082-91355-C000

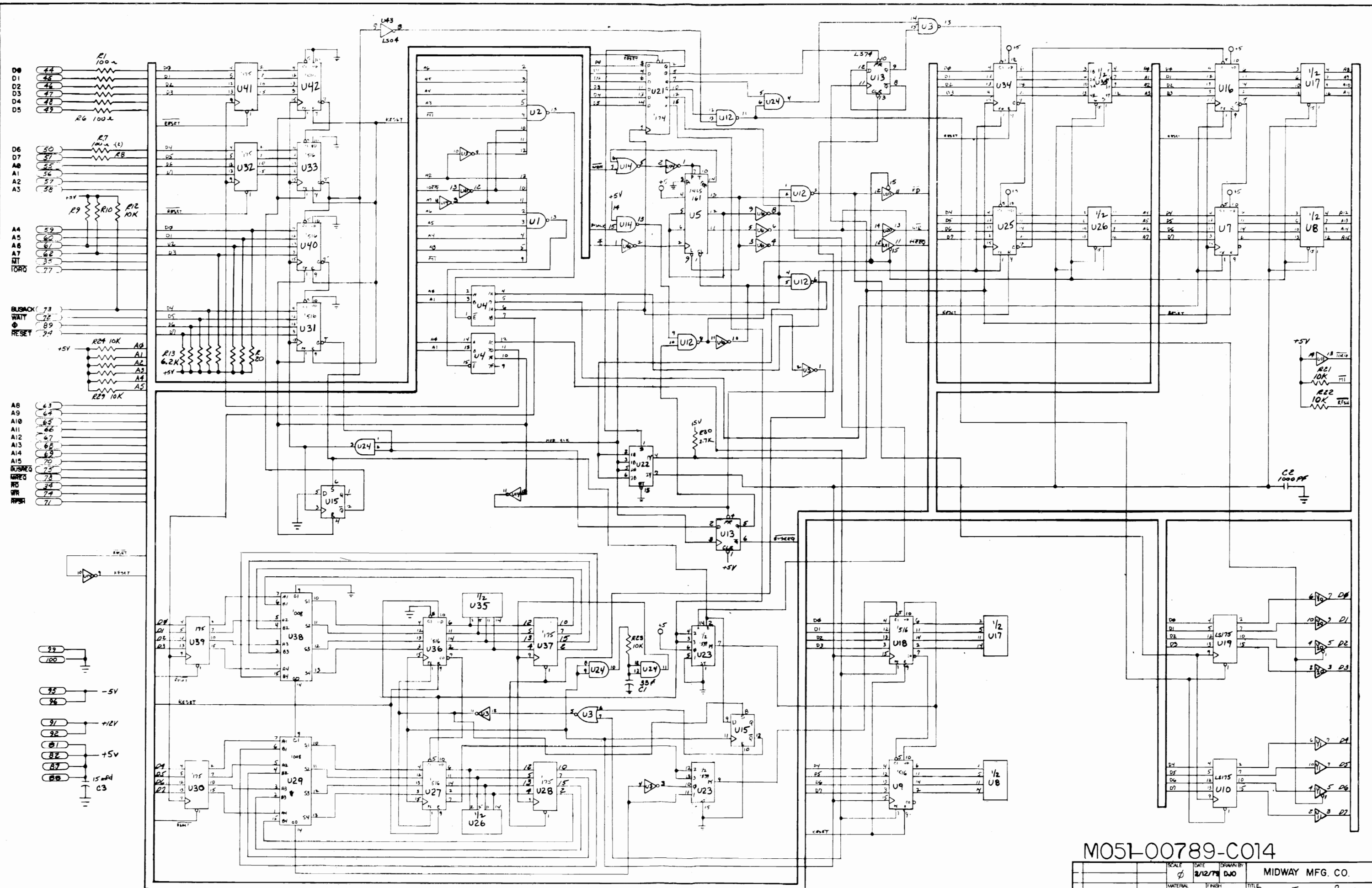

M051-00789-C014

SCALE	DATE	DESIGNED BY	MIDWAY MFG. CO.
1/2"	2/12/78	DJO	TITLE
MATERIAL	FINISH		PATTERN TRANSFER BOARD
			FOR
			CCRS
			NO. A082-91355-C000
C E30 Added	1980	TOLERANCES	
C ADDED U28	1/13/80	±0.1% 0.1	
C ADDED CA		±0.1% 0.1	

U10	74LS133	0066-061AX-XXDX	COMPONENT NO.	MIDWAY PART NO.
U11, U12, U13, U14	74LS138	0066-068AX-XXHX	74LS02	0066-463XX-XXRX
U15	74LS241	0066-464AX-XXHX	74LS08	0066-493XX-XXCX
			OR	
U16	74LS244	0066-467AX-XXHX	74LS32	0066-611XX-XXCX
X21 TO X28	14078	0066-301XX-XXDX	74LS30	0066-603XX-XXHX
	2114UCB	0066-131XB-XAAX	74LS32	0066-611XX-XXCX
			74LS74	0066-823XX-XXCX

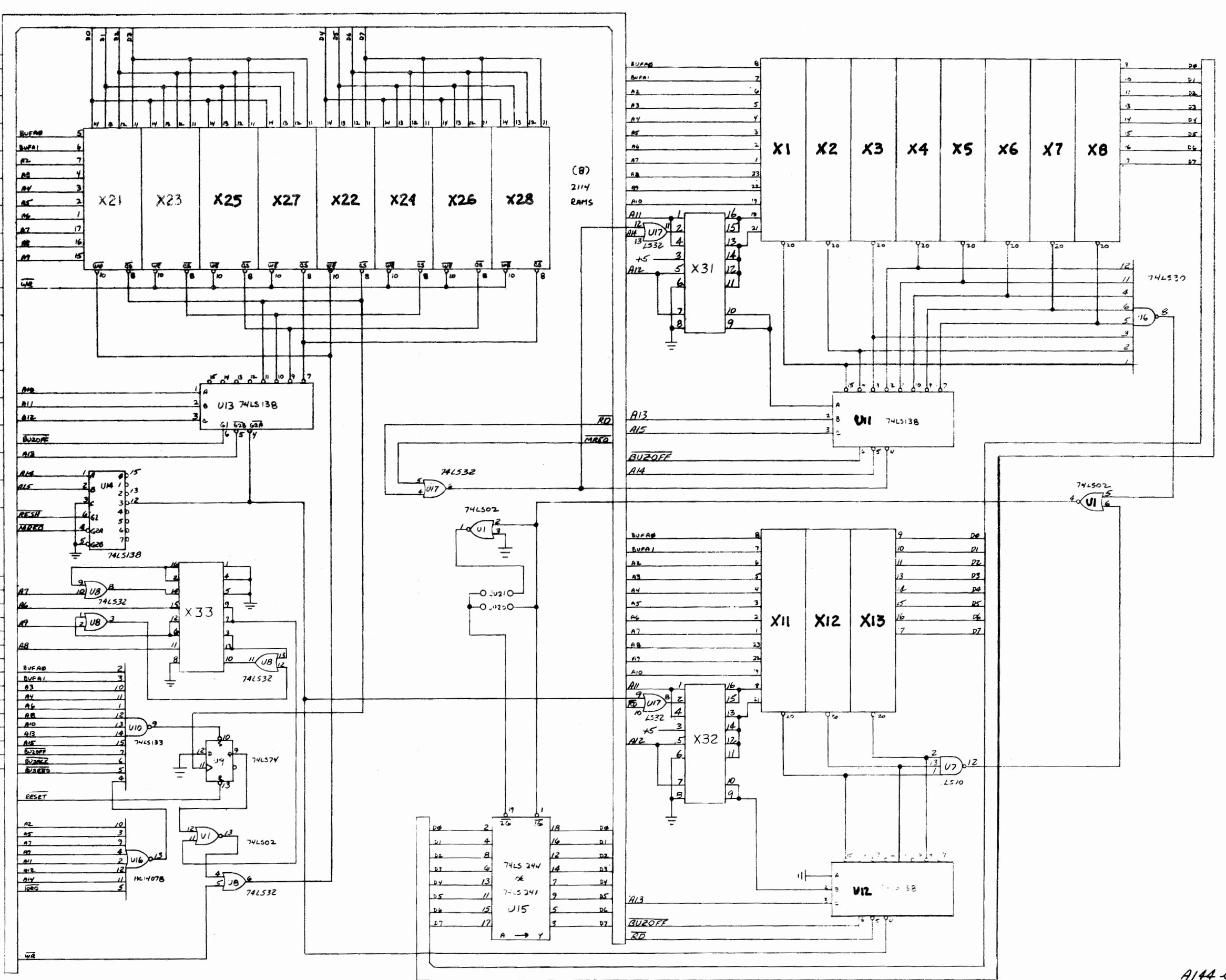
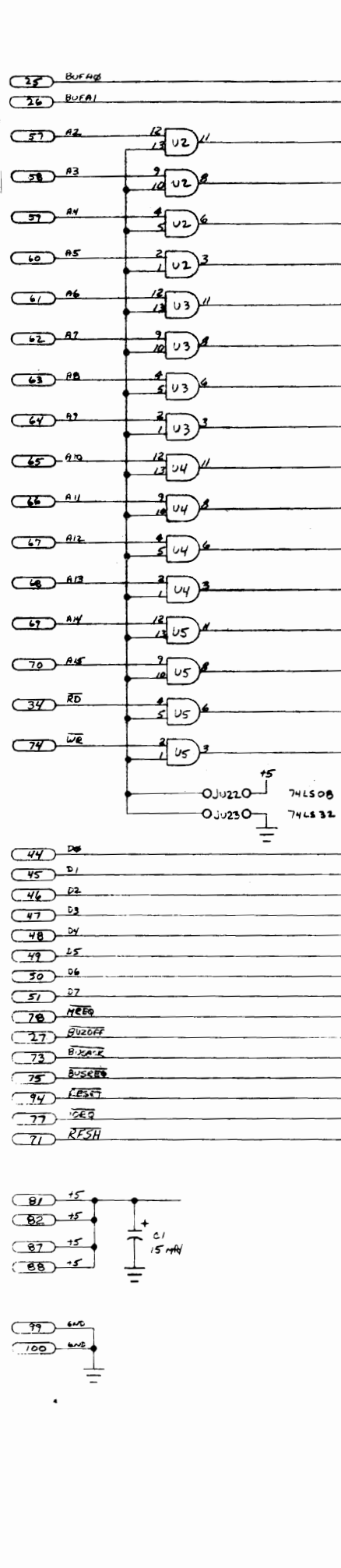

A144-01

SCALE	DATE	DRAWN BY	MIDWAY MFG. CO.
NONE	7-20-80	OTO	
MATERIAL	FINISH	TITLE	MEMORY BD
TOLERANCES	AS SHOWN	FOR	CCRS
NO	REV	NO	A082-91397-Ann

X3 0

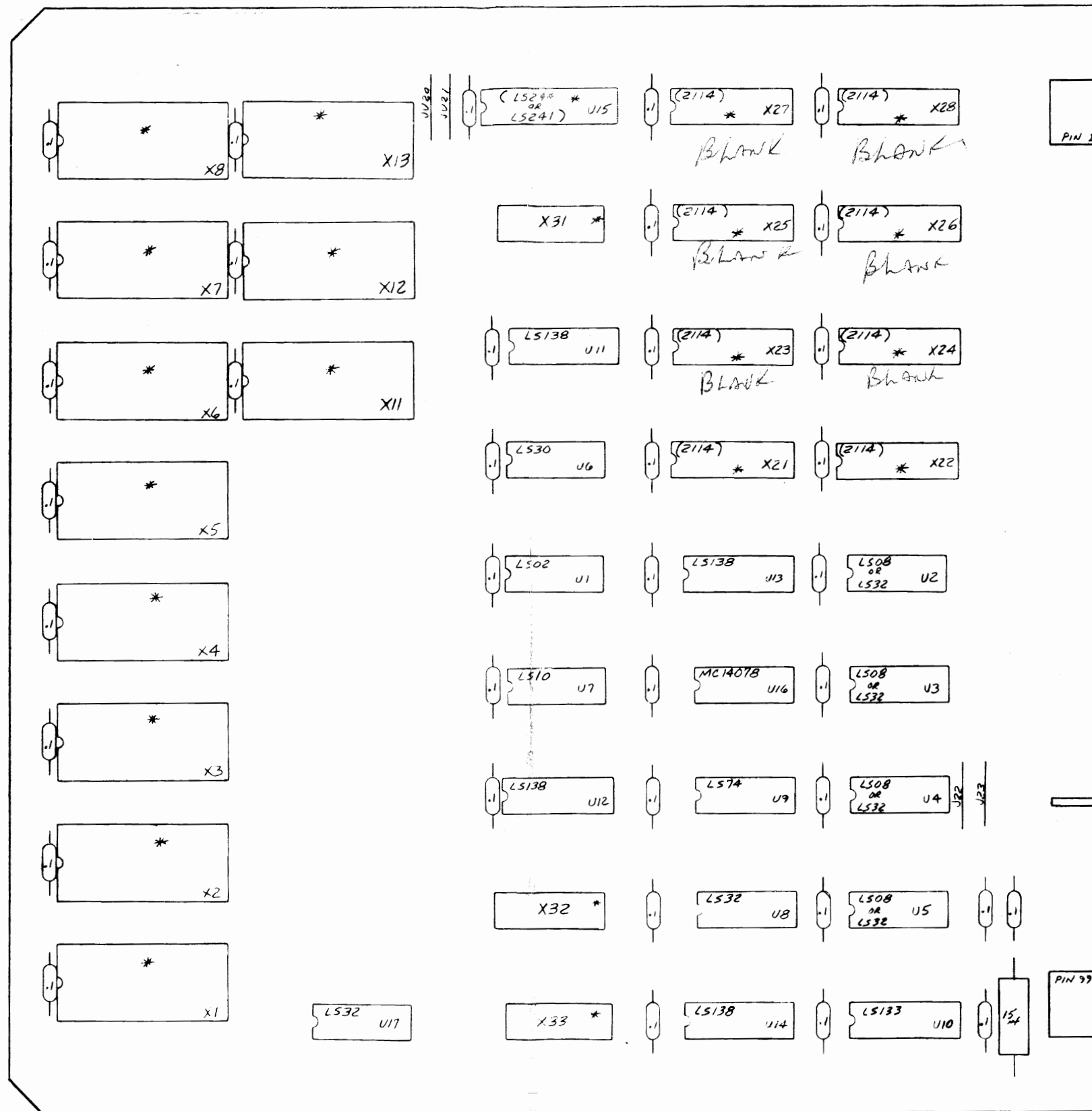

COMPONENT SIDE

* - DENOTES WHICH POSITION RECEIVES I.C. SOCKET

MOSI-30789-A027

SCALE	DATE	DRAWN BY	MIDWAY MFG. CO.
2/1	9/3/88	JAT	
MATERIAL	FINISH	TITLE	MEMORY BD.
FOR			CCR
NO.			A082-91397-A009

TOLERANCES:
XXX: .01
XXX: .008
ANGULAR: 1

A REL. TO POS. 1-81

COMPONENT DESIGNATION

U1, U2, U3, U8
 U4
 U5
 U6
 U9
 U10
 U11, U12, U18, U19
 U13
 U14, U17, U22
 U15, U16
 U20
 U21, U23
 U24
 Q5, Q6, Q7
 X1
 X2, X3

GAME BOARD

COMPONENT NO.

14539
 LM358
 74LS153
 14099
 74LS174
 74LS86
 74LS164
 74LS30
 74LS74
 74LS161
 74LS257
 74LS04
 74LS367
 TIP 110
 SC01
 CUSTOM I/O

MIDWAY PART NO.

0066-336XX-XXDX
 0066-034BX-XXAX
 0066-141AX-XXHX
 0066-311XX-XXEX
 0066-243AX-XXBX
 0066-883XX-XXDX
 0066-196AX-XXDX
 0066-603XX-XXHX
 0066-823XX-XXCX
 0066-183AX-XXHX
 0066-643AX-XXDX
 0066-473XX-XXAX
 0066-700AX-XXBX
 0065-491XX-XXGX
 0066-001XX-XAHX
 0066-117XX-XXYX

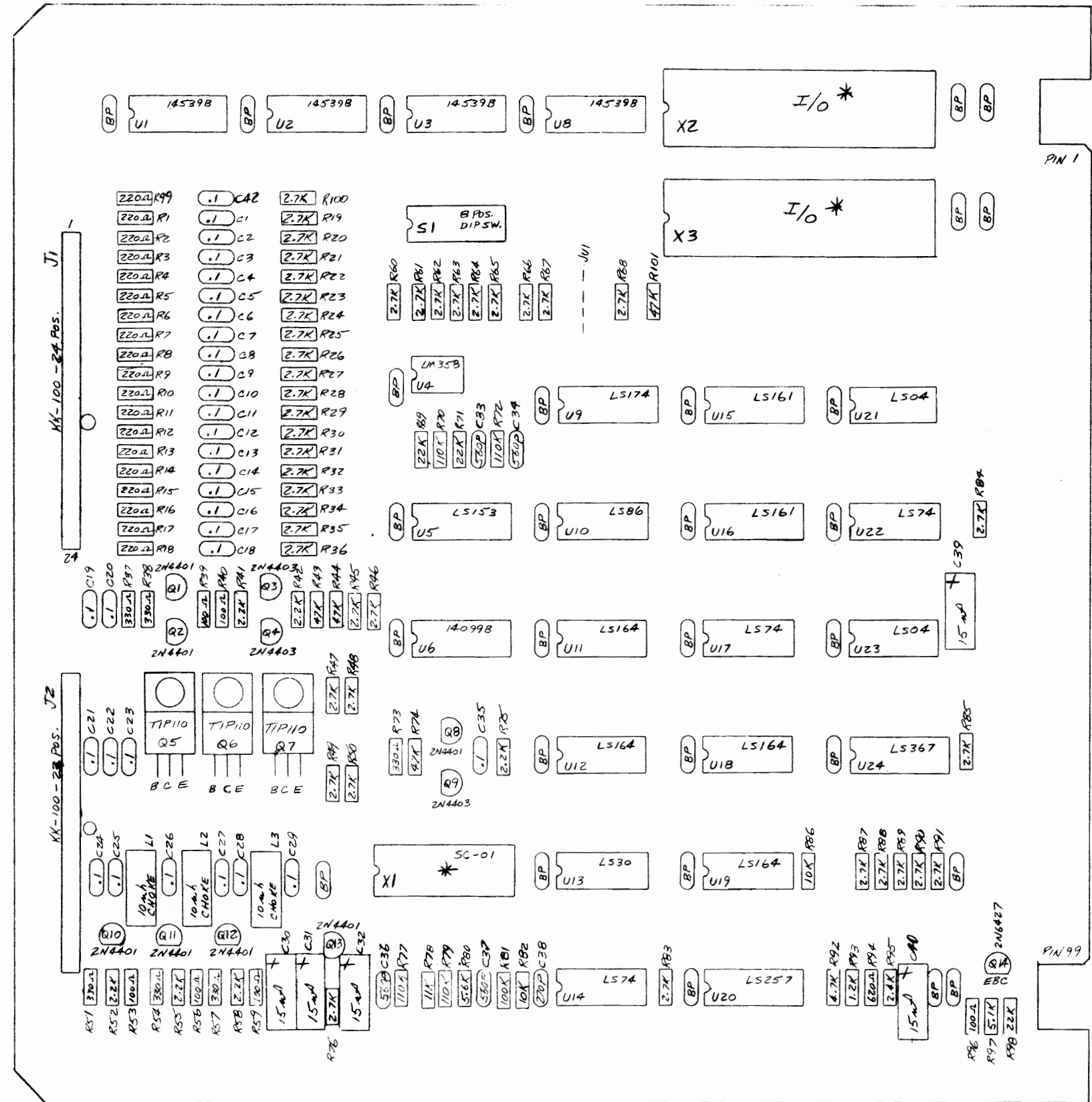

* X1, X2, X3 DENOTES
 SOCKETED POSITIONS

SCALE	DATE	DRAWN BY	Dave Nutting Associates
2:1	12-1-80	KCF	
MATERIAL	FINISH	TITLE	
		WIZARD OF WOR GAME BD	
TOLERANCES		FOR	
XXX .005		CCR	
ANGULAR	A139-02	NO A084-90708-A961	

M051-C0931-A028				A139-02			
SCALE	DATE	DRAWN BY	MIDWAY MFG. CO.				
2:1	12-1-80	KCF					
MATERIAL	FINISH	TITLE					
		WIZARD OF WOR GAME BD					
TOLERANCES		FOR					
XXX .005		CCR					
ANGULAR		NO A084-90708-A961					

