

Pandora's Palace™

© KONAMI 1983

CONVERSION KIT INSTRUCTION MANUAL

FOR ANY VERTICALLY MOUNTED
RASTAR SCAN MONITOR GAME

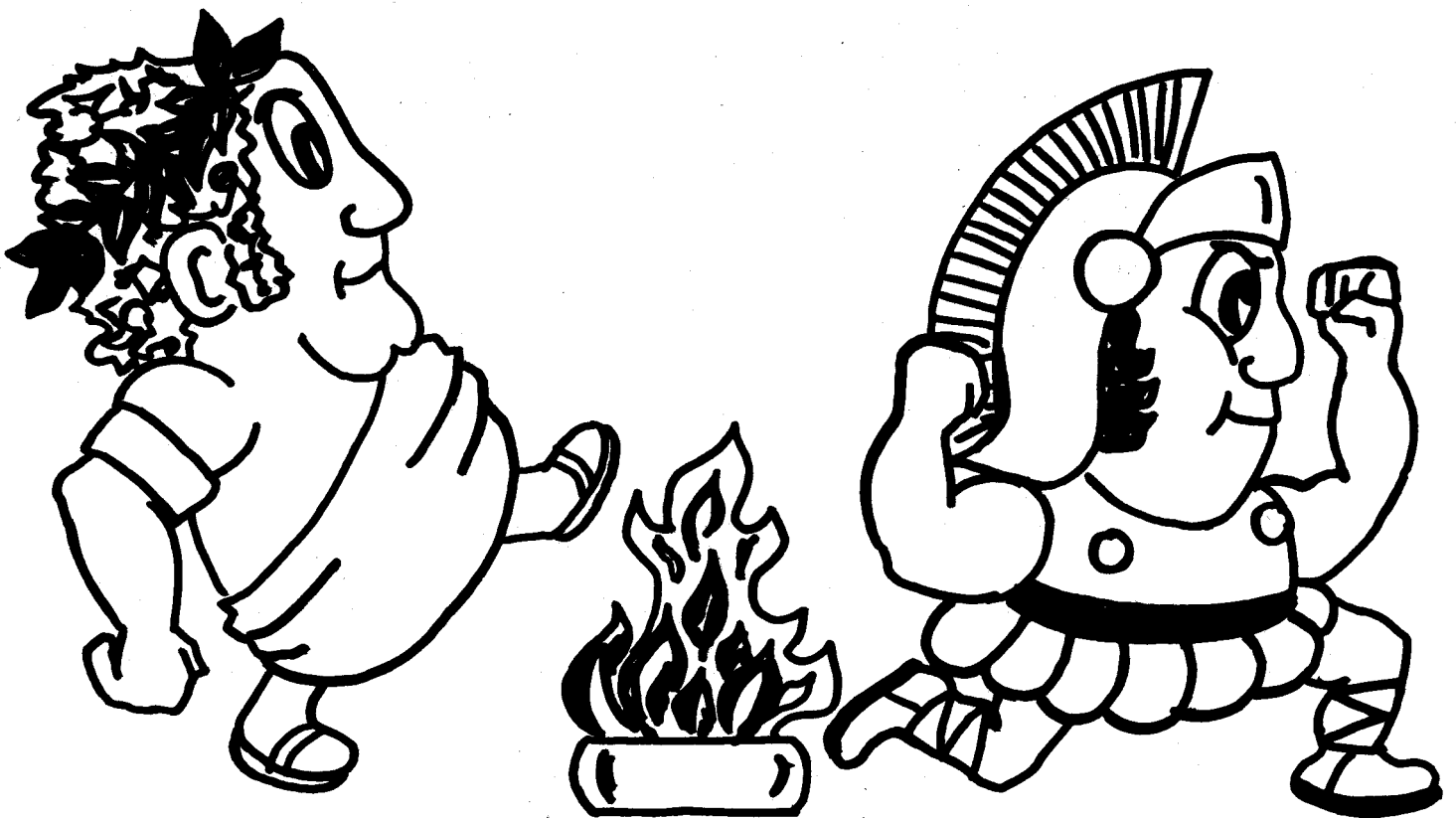

Konami®/interlogic® ©1984

TABLE OF CONTENTS

	Page
Conversion Kit Contents	Inside Cover
Table of Contents	1
Introduction	2
User Information Warning	4
Dip Switch Settings	5
I C Parts Layout Charts	6
General Wiring Diagram	8
Schematic Diagrams	Insert

INTRODUCTION

PANDORA'S PALACE is one of the most complete conversion kits available today. Every detail has been carefully considered, designed and packaged to provide you the means of easily producing a professional conversion.

We strongly urge you to FULLY STUDY this instruction manual BEFORE you begin your conversion. It contains step-by-step instructions, schematic diagrams and suggestions on how to assemble PANDORA'S PALACE and maximize your profits.

PANDORA'S PALACE can be installed in any

vertically mounted raster scan monitor game — UPRIGHT, MINI, OR COCKTAIL. For converting your cocktail model — dip-switch setting is on printed circuit board, additional wires are included in wiring harness, and two full sets of button/instruction decals are provided (4 each JUMP and 2 each INSTRUCTION).

Everything you will need to construct your new game is provided in this kit* All accessory parts — wiring harness, joy-stick, etc. are custom made for PANDORA'S PALACE by top engineers experienced in the coin-op industry.

PUTTING YOUR BEST GAME FORWARD

PREPARATION:

For best results, all old graphics should be removed completely from the cabinet. "Stick-on" graphics can be removed by using a hairdryer or hot air device. The heat from the dryer will loosen the adhesive, allowing you to easily peel them off — any adhesive residue can be cleaned off with acetone and a soft dry cloth. (DO NOT USE ACETONE ON SURFACES PAINTED WITH FLAT PAINT).

TOOLS YOU NEED:

1. Foaming Aerosol (such as "Windex").
2. Soft Squeegee (or cardboard).
3. X-Acto Knife.

4. Rigid Squeegee (included).

SIDE PANEL DECALS:

1. Spray area of cabinet where side decals are to be applied with foaming aerosol or a mild soap solution.
2. Remove protective backing from decals.
3. Position decals into place.
4. With a soft squeegee and beginning from the center of the decal, slowly and evenly press out excess foam until you achieve a smooth finish.
5. Allow to set approximately 2 to 3 hours before handling. Maximum adherence is achieved in 48 to 72 hours.

3 LAYER CONTROL PANEL OVERLAY (KONAMI/INTERLOGIC EXCLUSIVE)

1. Pre-drill control panel for any additional holes needed for joysticks or buttons.
2. Pre-position 4 mil. printed vinyl overlay (Roman Columns) prior to removing backing.
3. Slowly apply overlay — removing backing as you apply it to the surface. Be sure all air pockets are removed. (Minor air pockets may be popped with a pin). IT IS NOT RECOMMENDED TO USE FOAMING AEROSOL IN THIS STEP SINCE TWO MORE LAYERS MUST BE APPLIED WHICH WOULD BE ADVERSELY AFFECTED BY ANY MOISTURE LEFT UNDER THE 4 MIL. VINYL OVERLAY.
4. Next, position instruction and button decals (1 Player, 2 Player and Jump) where desired on top of 4 mil. vinyl overlay, by peeling off die-cut decals from 6" x 9" decal sheet and applying. Be sure to allow room for button collars.
5. Remaining decorative decals are to be used to customize and increase attractiveness of your game.
6. Apply the clear 10 mil. suede Lexan sheet (as you did the printed overlay) over the control

panel completely covering all decals applied in steps 2 thru 5. DO NOT USE FOAMING AEROSOL OR ANY LIQUID UNDER ANY CIRCUMSTANCES IN THIS STEP!

7. Appearance of control panel will now be somewhat cloudy. Using a blow-dryer (set on high) or a hot-air device, heat up Lexan which you have just applied, one section at a time. As you do this, rub down clear suede Lexan (using a very rigid squeegee — included) applying pressure liberally, especially around button/decorative decals. If the control panel has been heated enough (it must be hot, not just warm), the result will be a crystal clear control panel.
8. Using an X-Acto knife, cut around joystick and button placements.

THE KONAMI/INTERLOGIC NEW STYLE CONTROL PANEL WILL TAKE A LITTLE EXTRA TIME TO APPLY. HOWEVER, THE BETTER YOUR GAME LOOKS, THE MORE IT WILL EARN! THE 3-LAYER KONAMI/INTERLOGIC DESIGNED CONTROL PANEL PREVENTS PLAYERS FROM PEELING INSTRUCTION/BUTTON DECALS WHICH DEFACES YOUR GAME.

*NOTE: POWER SUPPLY MUST HAVE
+5V 5.0A
+12V 1.0A or 2.0A
CURRENT PARAMETERS

MARQUEE

1/8" Acrylic Marquee should cut to fit your game. DO NOT remove protective mask until this is done.

One way of cutting your Marquee is as follows: (Be sure to protect painted side of Marquee from any surface which may scratch or mar finish).

CUTTING WITH A KNIFE OR SCRIBER

Acrylic sheet up to 3/16" thick may be cut by a method similar to that used for cutting window glass. Use a scriber of some kind — a scribing knife such as the one pictured, a metal scriber, an awl, or even a sturdy craft knife — to score the sheet. Draw the scriber several times (7 or 8 times for a 3/16" thick piece) along a straight edge held firmly in place. It is best not to remove the protective masking. Make the cuts carefully using firm, even pressure. For best results make each stroke cleanly off the edge of the sheet.

Then, clamp the acrylic sheet or hold it rigidly under a straight edge with the scribe mark hanging just over the edge of a table. Protect your hands with a cloth, and apply a sharp downward pressure to the other side of the sheet. It will break along the scratch. Scrape the edges to smooth any sharp corners. This method is not recommended for long breaks or thick material.

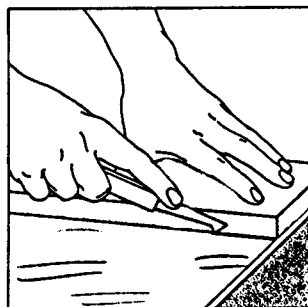

Always draw the scribing knife along a straight edge.

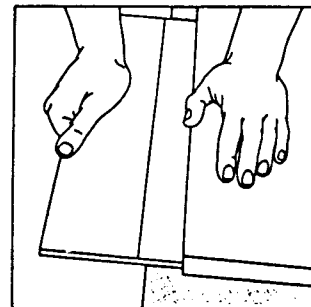

Break sheet over edge of table after scribing.

DIAGNOSTIC PROCEDURES

AUTOMATIC SELF-TEST — Upon "Power On", this system will automatically test ROMS and VIDEO RAMS. The screen will display pass or fail conditions as follows:

ROM OK
RAM OK = TEST PASSED
BAD ROM
BAD RAM = TEST FAILED

If there is a problem, before contacting your distributor:

1. Check that all chips on board and wiring connections are tight.
2. Check output from power supply at the board. (Do not just check at the power supply as voltage drops may occur over the length of the wire.)

MANUAL TEST — A more detailed six-step diagnostic may be performed by depressing the One and Two Player Start Buttons simultaneously during power turn on. When the "cross-hatch" pattern appears, release the buttons and proceed as follows:

1 "CROSS-HATCH" PATTERN — When "cross-hatch" is displayed, adjustments to the monitor may be needed for proper picture. Horizontal and Vertical size controls should be adjusted so that the borders of "cross-hatch" extend to the borders of the picture tube. Color and brightness should be adjusted for white lines and black background.

2 COLOR TEST — From "cross-hatch" pattern,

press One Player Start and the screen will display sixteen color blocks. If a block shows any irregularities (e.g., lines or dots in color blocks), this could be due to a failure of VIDEO RAM, COLOR RAM, or OBJ CIRCUITS. Use these blocks to further adjust monitor focus and colors.

3 SWITCH TEST — From color test, press One Player Start and the screen will display all switches with a zero (0) to the right. When a switch is activated the zero (0) should change to a one (1).

4 COIN COUNTER TEST — From switch test, press One Player Start and the screen will display "coin counter". While number one (1) is shown, counter one should pulse eight times. When number two (2) is shown, counter two should pulse eight times and the screen will automatically advance to the next test.

5 DIP SWITCH SETTINGS — From coin counter test, the screen will automatically display all programmable features with their respective settings. These settings should correspond to the position of the dip switches.

6 SOUND TEST — From dip switch settings, press One Player Start. The screen will automatically display one of thirty-four sound codes every eight seconds (in a hexadecimal sequence), with a different sound produced for each. To cycle the codes, quickly, use Two Player Start.

TO EXIT DIAGNOSTICS —
TURN POWER OFF AND ON.

PANDORA'S PALACE DIP SWITCH SETTINGS:

A. DIP 1 SWITCH SETTING

FIG. 1. — COIN 1 SW SETTING / COIN 2 SW SETTING

COIN 1 SW SETTING				COIN 2 SW SETTING				COIN	PLAY	
SW	1	2	3	4	5	6	7			8
	OFF	OFF	OFF	OFF	OFF	OFF	OFF	OFF	1	1
	ON	OFF			ON	OFF			1	2
	OFF	ON			OFF	ON			1	3
	ON	ON			ON	ON			1	4
	OFF	OFF	ON	OFF	OFF	OFF	ON	OFF	1	5
	ON	OFF			ON	OFF			1	6
	OFF	ON			OFF	ON			1	7
	ON	ON			ON	ON			2	1
	OFF	OFF	OFF	ON	OFF	OFF	OFF	ON	2	3
	ON	OFF			ON	OFF			2	5
	OFF	ON			OFF	ON			3	1
	ON	ON			ON	ON			3	2
	OFF	OFF	ON	ON	OFF	OFF	ON	ON	3	4
	ON	OFF			ON	OFF			4	1
	OFF	ON			OFF	ON			4	3
	ON	ON			ON	ON			FREE PLAY 1-4	

B. DIP 2 SWITCH SETTINGS

FIG. 1. — THE NUMBER OF PLAYERS

SW	1	2	NUMBER
0	OFF	OFF	3
	ON	OFF	4
	OFF	ON	5
	ON	ON	7

FIG. 4. — DIFFICULTY OF THE GAME

SW	6	7	DIFFICULTY
	OFF	OFF	1 EASY
0	ON	OFF	2
	OFF	ON	3
	ON	ON	4 DIFFICULT

FIG. 2. — SWITCH FOR CHANGE OF TABLE OR UPRIGHT

SW	3	TYPE
	OFF	TABLE-USING I/O FOR 1 OR 2 PLAYER
0	ON	UPRIGHT-USING I/O FOR 1 PLAYER ONLY

FIG. 5. — MUSIC IN ATTRACT MODE

SW	8	MUSIC IN ATTRACTIVE MODE
	OFF	OFF
0	ON	ON

FIG. 3. — BONUS SETTING

SW	4	5	BONUS PLAYER
0	OFF	OFF	1st as 20,000 points 2nd as 80,000 points and every 60,000 points
	ON	OFF	1st as 30,000 points 2nd as 100,000 points and every 70,000 points
	OFF	ON	only 20,000 points
	ON	ON	only 30,000 points

NOTE: "O" SHOWS NORMAL SETTING. THE LEVEL OF DIFFICULTY OF THIS GAME WAS SET BY KONAMI FOR THE AVERAGE PLAYER'S SKILL. SHOULD YOU CHOOSE TO INCREASE THE DIFFICULTY OF THE GAME, DO SO WITH DISCRETION.

PANDORA'S PALACE: I C Parts Layout Chart

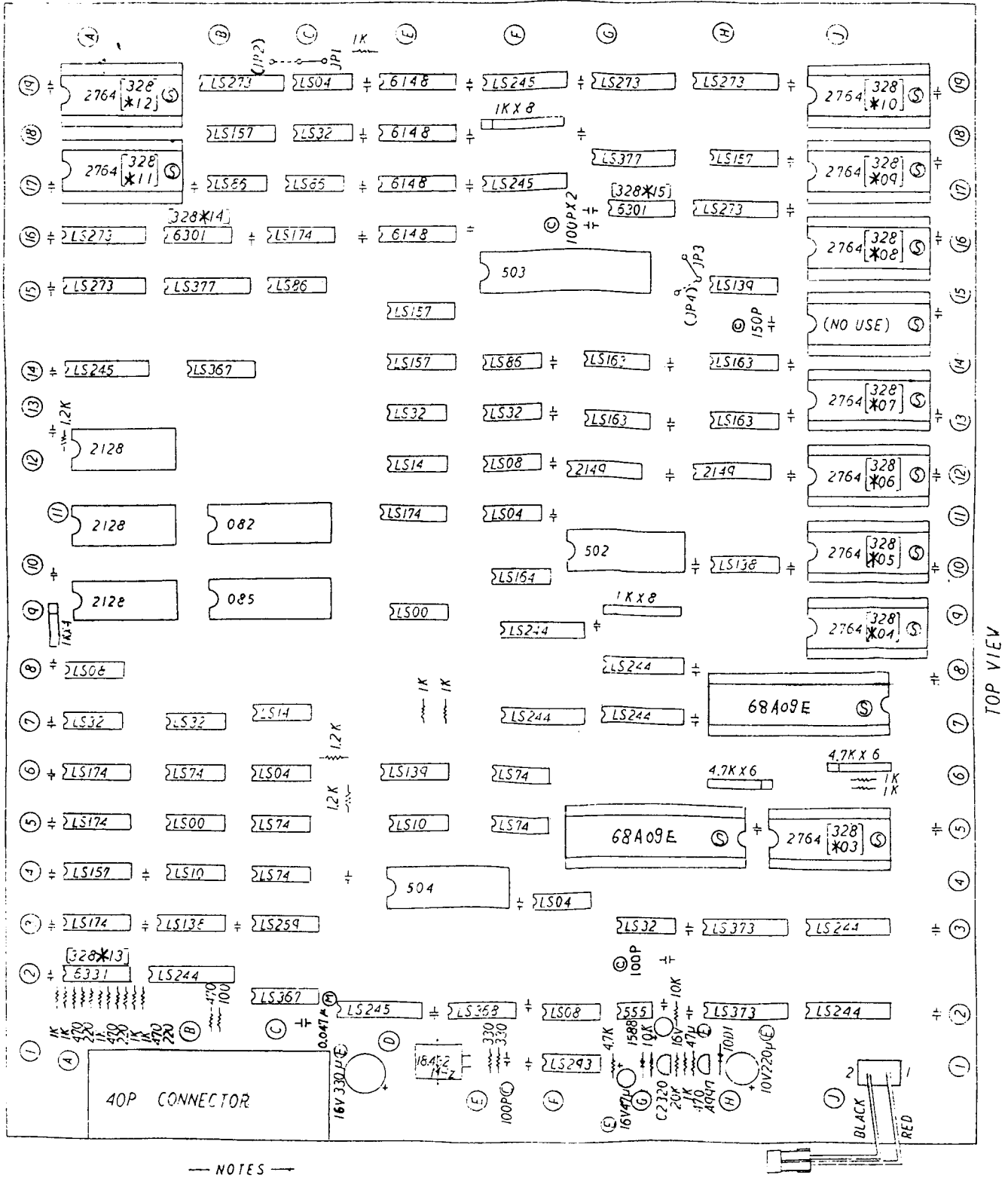

— NOTES —

- (C) : CERAMIC CAPACITOR
- (E) : ELECTROLYTIC CAPACITOR
- (M) : MYLAR CAPACITOR
- (S) : IC SOCKET
- † NO MARK : 0.01µ CERAMIC CAPACITOR
- [] : ROM LABEL NUMBER
- () : NO RAYOUT PARTS
- * : "A" THROUGH "Z"

PANDORA'S PALACE: General Wiring Diagram

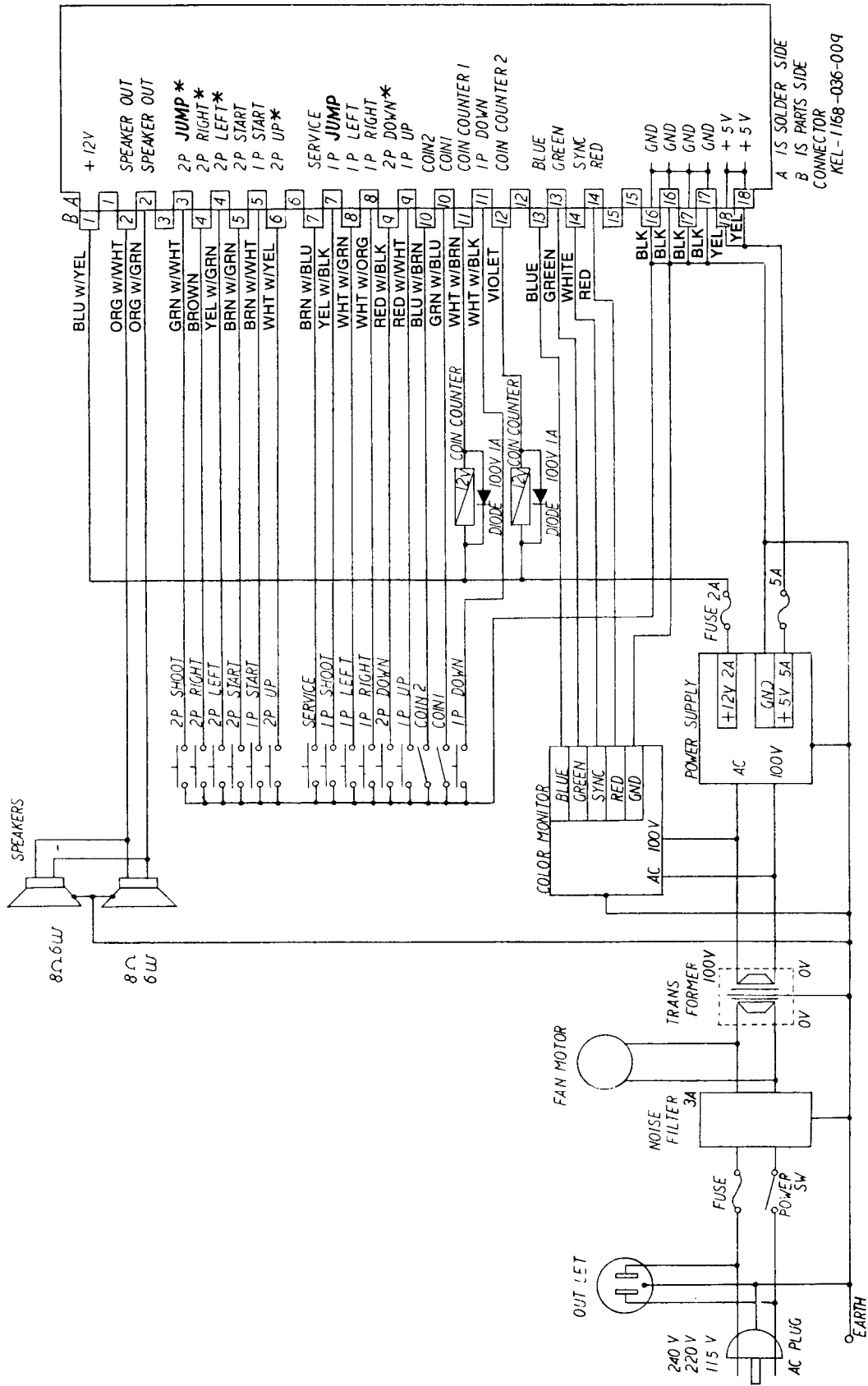

* Table type only

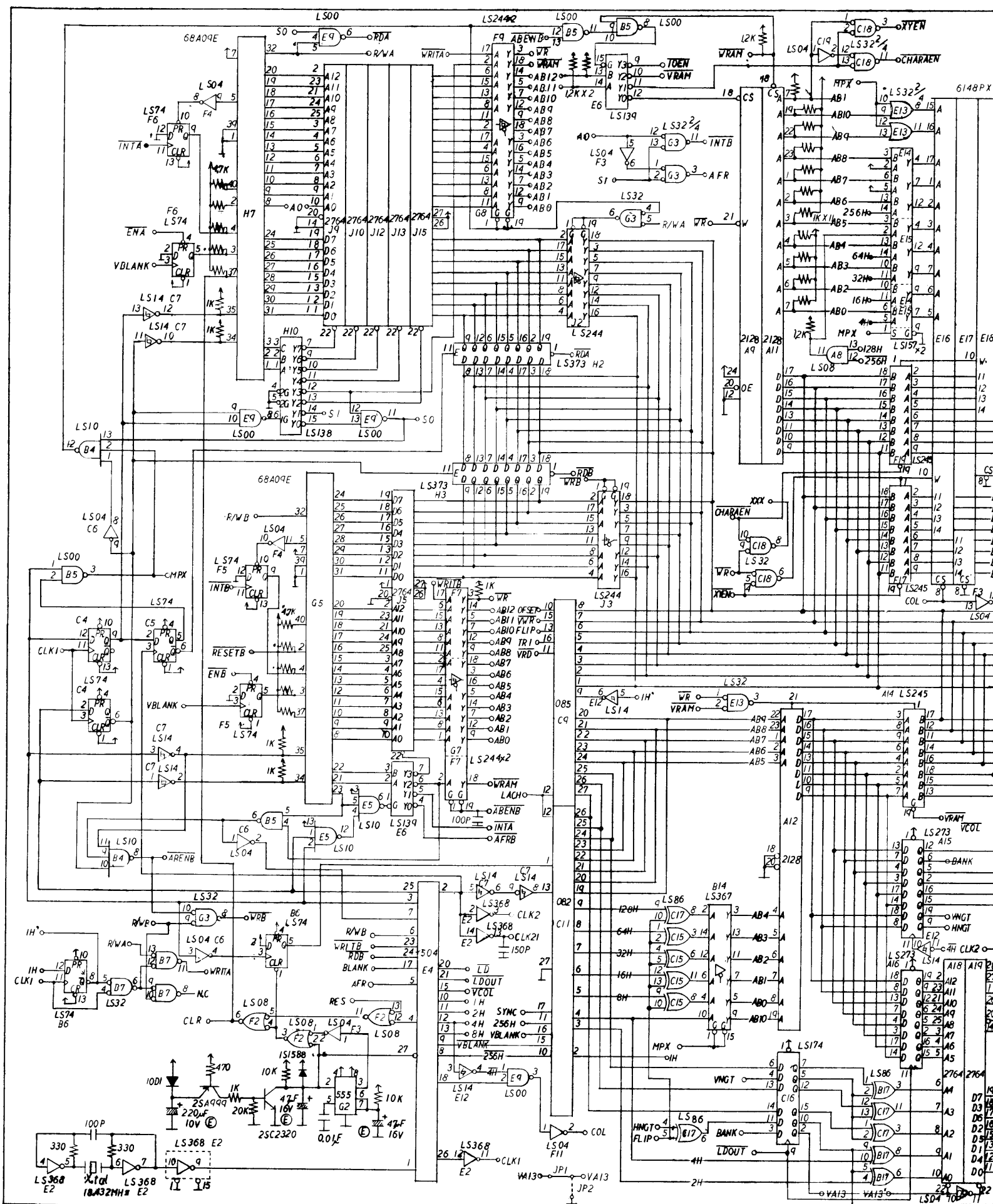

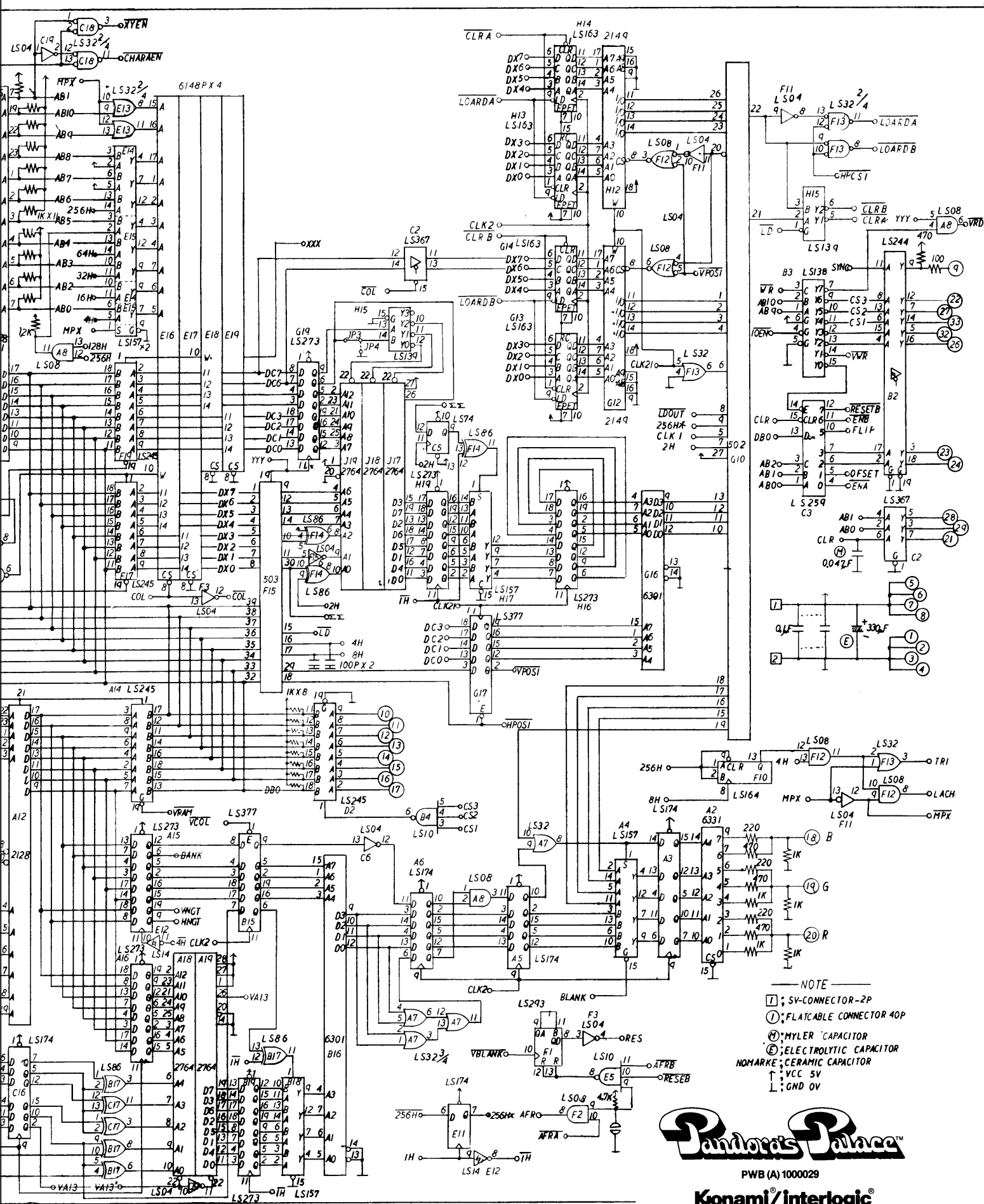

NOTE

- ①: SV-CONNECTOR-2P
- ②: FLATCABLE CONNECTOR 40P
- Ⓜ: MYLER CAPACITOR
- ⓔ: ELECTROLYTIC CAPACITOR
- NONMARKE: CERAMIC CAPACITOR
- ↑: VCC 5V
- ⊥: GND 0V



PWB (A) 1000029

Konami/Interlogic
© 1984

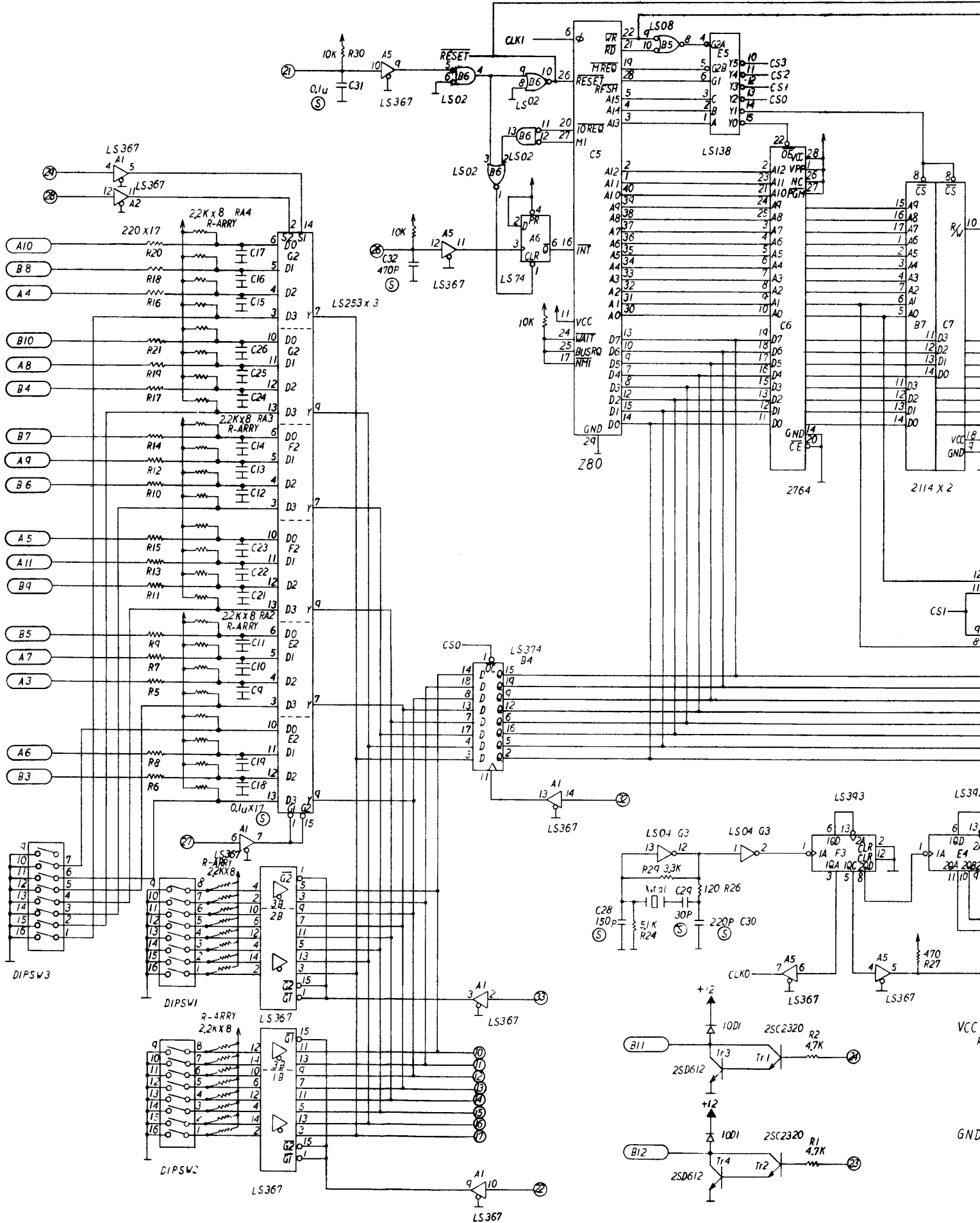

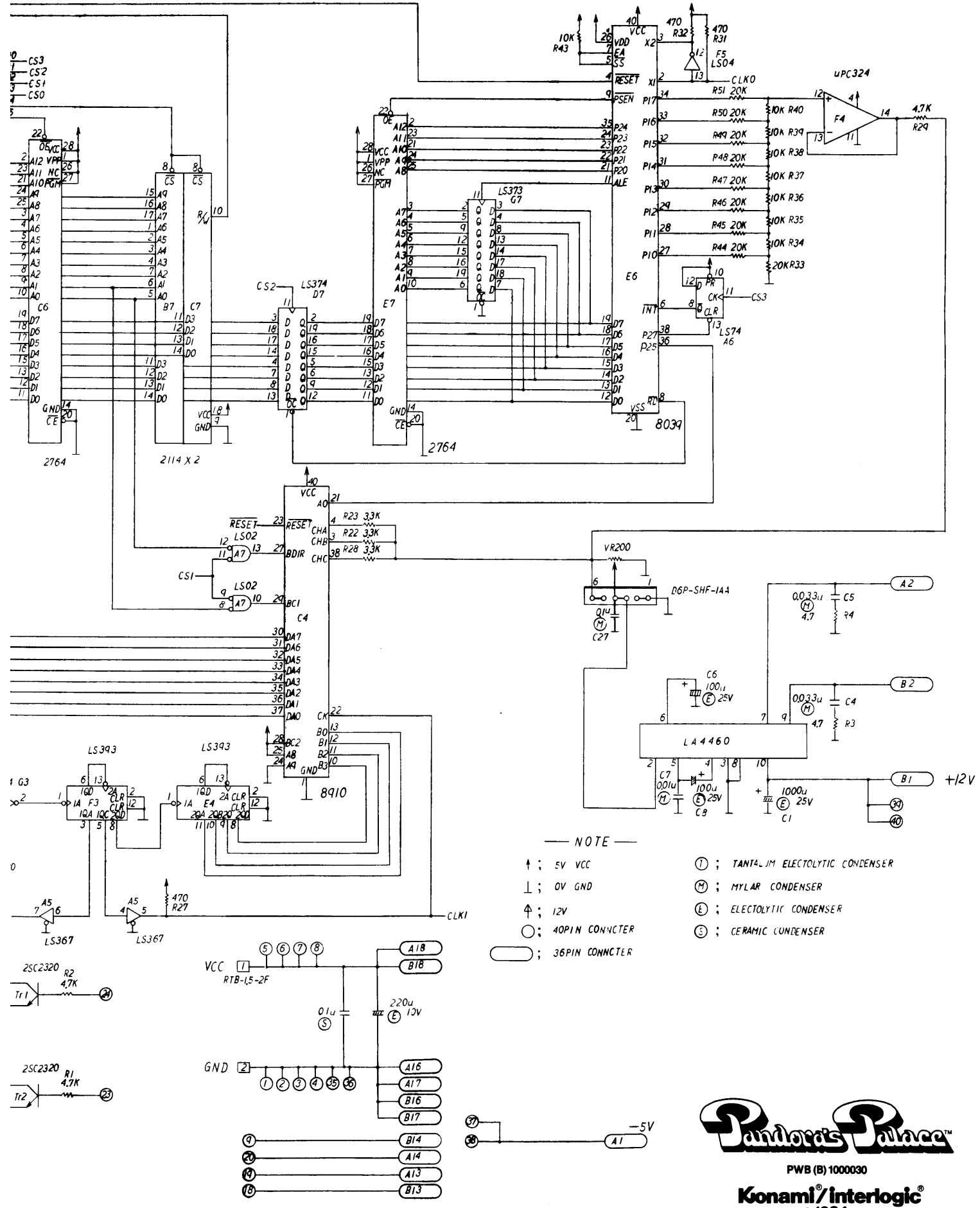

— NOTE —

- ↑ ; 5V VCC
- ⊥ ; 0V GND
- ⤴ ; 12V
- ; 40PIN CONNECTER
- ; 36PIN CONNECTER
- Ⓜ ; TANTALUM ELECTROLYTIC CONDENSER
- Ⓜ ; MYLAR CONDENSER
- Ⓜ ; ELECTROLYTIC CONDENSER
- Ⓜ ; CERAMIC CONDENSER



PWB (B) 1000030

Konami®/Interlogic®
© 1984