

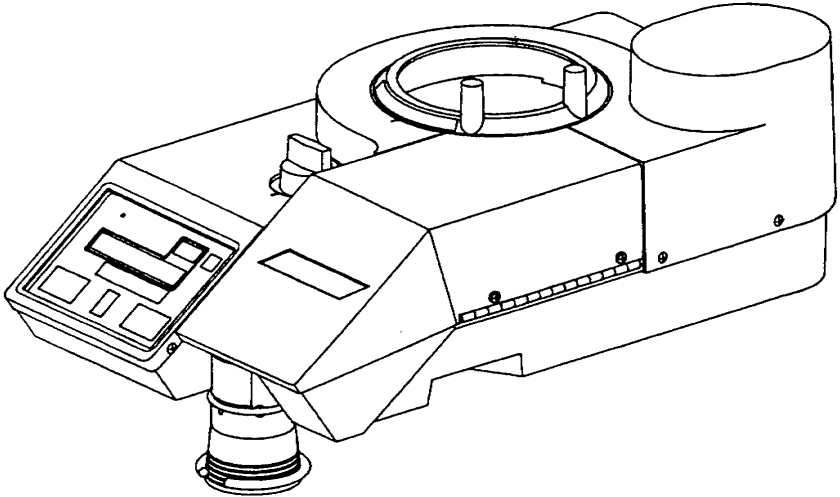

BRANDT®

MODEL 7500 / 7550

COIN COUNTER / PACKAGER



OPERATOR
MANUAL

OPERATOR MANUAL

MODEL 7500 / 7550 SERIES COIN COUNTER/PACKAGER

CAUTION

SAFE OPERATION OF THIS PRODUCT IS DEPENDENT UPON PROPER INSTALLATION WITH COMPATIBLE BRANDT EQUIPMENT AND BY AN AUTHORIZED BRANDT REPRESENTATIVE. INCOMPLETE OR INCORRECT INSTALLATION MAY RESULT IN DAMAGE TO THE EQUIPMENT OR PERSONAL INJURY. ACCIDENTS CAN BE AVOIDED IF THE OPERATOR IS COMPLETELY FAMILIAR WITH THIS PRODUCT AND ITS OPERATION. NEVER ALLOWS TOOLS, FINGERS, HAIR OR LOOSE CLOTHING NEAR MOVING PARTS. NO ATTEMPT SHOULD BE MADE TO DISASSEMBLE THIS PRODUCT. IF SERVICE IS REQUIRED, CONTACT YOUR AUTHORIZED BRANDT SERVICE REPRESENTATIVE.

WARNING

THIS DIGITAL APPARATUS DOES NOT EXCEED THE CLASS A LIMITS FOR RADIO NOISE EMISSIONS FROM DIGITAL APPARATUS SET OUT IN THE RADIO INTERFERENCE REGULATIONS OF THE CANADIAN DEPARTMENT OF COMMUNICATIONS.

LE PRESENT APPAREIL NUMERIQUE N'EMET PAS DE BRUITS RADIOELECTRIQUES DEPASSANT LES LIMITES APPLICABLES AUX APPAREILS NUMERIQUES LA CLASS A PRESCRITES DANS LE REGLEMENT SUR LE BROUILLAGE RADIOELECTRIQUE EDICTS PAR LE MINISTERE DES COMMUNIATIONS DUE CANADA.

The information contained herein is proprietary and is not to be used for purposes other than as an aid in the operation and/or maintenance of the equipment described herein and is further not to be released or reproduced by anyone without the written permission of:

BRANDT, INC.
COIN PRODUCTS OPERATIONS
705 SOUTH 12TH STREET
WATERTOWN, WISCONSIN 53094, U.S.A.

#0000792
REV 04

©COPYRIGHT 1991
ALL RIGHTS RESERVED

Printed
in USA

TABLE OF CONTENTS

	PAGE
1. INTRODUCTION	1
2. SPECIFICATIONS	2
3. UNPACKING AND INSPECTION	2
4. PREPARATION FOR USE	
INSTALLATION	2
CHECK FOR PROPER VOLTAGE/POLARITY	4
CONNECTING TO POWER	5
INSTALLING THE OFFSORT CUP	5
INSTALLING A COIN TUBE	6
INSTALLING A COIN BAG	7
SETTING THE THICKNESS GAUGE	8
SETTING THE DIAMETER GAUGE	9
UNDERSTANDING THE CONTROL(S)	10
A. THE TWO-DIGIT CONTROL	10
B. THE THREE-DIGIT CONTROL	13
5. OPERATION	
COUNTING/VERIFYING	17
WRAPPING	17
BAGGING	18
COUNT TOTALS	19
AUTOMATIC DISC REVERSE	19
AUTOMATIC SHUTDOWN	19
6. JAM CLEARING	19
7. BENT OR MUTILATED COINS	20
8. TROUBLESHOOTING GUIDE	21

9. OPERATOR MAINTENANCE

CLEANING THE COUNT SENSOR 22
RESETTING THE CIRCUIT BREAKERS 22
REPLACING THE FUSES 23
REPLACING THE EJECTOR BELT 24

10. CARE OF THE PACKAGER 25

NOTE:

THIS EQUIPMENT HAS BEEN TESTED AND FOUND TO COMPLY WITH THE LIMITS FOR A CLASS A DIGITAL DEVICE, PURSUANT TO PART 15 OF THE FCC RULES. THESE LIMITS ARE DESIGNED TO PROVIDE REASONABLE PROTECTION AGAINST HARMFUL INTERFERENCE WHEN THE EQUIPMENT IS OPERATED IN A COMMERCIAL ENVIRONMENT. THIS EQUIPMENT GENERATES, USES AND CAN RADIATE RADIO FREQUENCY ENERGY AND, IF NOT INSTALLED AND USED IN ACCORDANCE WITH THE INSTRUCTION MANUAL, MAY CAUSE HARMFUL INTERFERENCE TO RADIO COMMUNICATIONS. OPERATION OF THIS EQUIPMENT IN A RESIDENTIAL AREA IS LIKELY TO CAUSE HARMFUL INTERFERENCE IN WHICH CASE THE USER WILL BE REQUIRED TO CORRECT THE INTERFERENCE AT HIS OWN EXPENSE.

"THE USER IS CAUTIONED THAT ANY CHANGES OR MODIFICATIONS NOT EXPRESSLY APPROVED BY THE PARTY RESPONSIBLE FOR COMPLIANCE COULD VOID THE USER'S AUTHORITY TO OPERATE THE EQUIPMENT."

 WARNING

THIS DIGITAL APPARATUS DOES NOT EXCEED THE CLASS A LIMITS FOR RADIO NOISE EMISSIONS FROM DIGITAL APPARATUS SET OUT IN THE RADIO INTERFERENCE REGULATIONS OF THE CANADIAN DEPARTMENT OF COMMUNICATIONS.

LE PRESENT APPAREIL NUMERIQUE N'EMET PAS DE BRUITS RADIOELECTRIQUES DEPASSANT LES LIMITES APPLICABLES AUX APPAREILS NUMERIQUES LA CLASS A PRESCRITES DANS LE REGLEMENT SUR LE BROUILLAGE RADIOELECTRIQUE EDICTS PAR LE MINISTRE DES COMMUNICATIONS DUE CANADA.

1. INTRODUCTION

The Model 7500 / 7550 Coin Counter and Packager is easy to operate. Coins are counted and packaged with great speed and accuracy. Accessories needed for wrapping or bagging coin are included. Additional options, such as Autofeed, Crimper and Offsort Bagging are available through your Brandt Authorized Representative. This Manual covers all procedures for efficient, trouble-free operation. Read this Manual thoroughly before operating.

Due to Brandt's constant strive for product improvement, minor discrepancies between the actual packager, text and illustrations may exist. All information contained herein is based on the latest specifications at time of publication.

When replacement parts are required, contact your Authorized BRANDT Service Representative and obtain only GENUINE BRANDT parts. Original equipment replacement parts will insure that you receive the RELIABILITY, PERFORMANCE and SAFETY that was designed into your BRANDT equipment.

2. SPECIFICATIONS *

Height	8 Inches (203 mm)
Width	12.5 Inches (317mm)
Depth	23.5 Inches (597mm)
Weight	45 Pounds (20.4kg)
Voltage	115 VAC-60 HZ (6 AMP – Nominal) 230 VAC-50 HZ (2 AMP – Nominal)
Coin Thickness\$040 to .125 Inches (1.016mm to 3.175mm)
Coin Diameter590 to 1.500 Inches (14.986mm to 38.1mm)
Counting Speed	Up to 4,000 U.S. Dimes/Minute
Hopper Capacity	Up to 2,100 U.S. Dimes
Temperature Range	+40 to +115 Degrees Fahrenheit (+5 to +50 Degrees Centigrade)
Programmable Bagstops	1 through 999,999
Preset Bagstops	20, 25, 40, 50

* Specifications are approximate and subject to change without notice.

3. UNPACKING AND INSPECTION

The Packager was completely tested, inspected and carefully packed when it left the factory.

Remove the Packager from the shipping carton and carefully inspect for damage.

If it was damaged in shipment, file a claim with the carrier without delay. Save the shipping carton and packing for the carrier's inspection.

Compare the contents of the carton to the original order to be sure all parts were included as ordered. Contact your Brandt Representative with any discrepancies.

4. PREPARATION FOR USE

INSTALLATION

The Packager should be placed on a level surface to assure proper operation. Ample room should be allowed for the Inspection Pan and Power Cord, as well as a front overhang for Coin Tube/Coin Bag, Offsort Receptacle and any accessories; i.e., Crimper, etc.

CAUTION

IF THE PACKAGER IS TO BE USED FOR BAGGING LARGE (HEAVY) QUANTITIES OF COIN, IT MUST BE SECURED TO THE SURFACE ON WHICH IT SITS TO PREVENT IT FROM BEING PULLED FORWARD FROM THE WEIGHT OF THE COIN BAG. TWO 1/4-20 TAPPED HOLES ARE PROVIDED IN THE BASE FOR MOUNTING (SEE FIGURE #1) USING THE HARDWARE SUPPLIED. DO NOT OVERTIGHTEN! THE BASE IS ALUMINUM AND THE THREADS MAY STRIP.

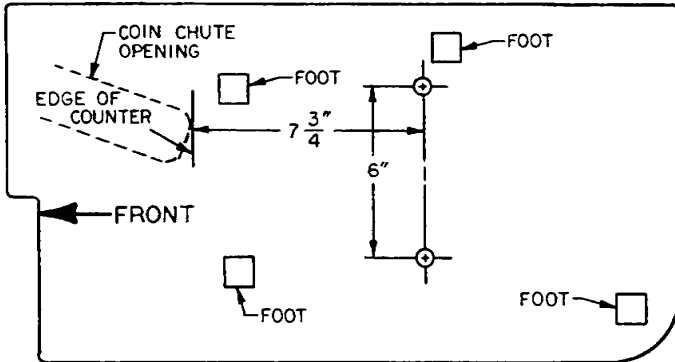

FIGURE #1
MOUNTING HOLE LOCATION
(VIEWED FROM BOTTOM)

CHECK FOR PROPER VOLTAGE/POLARITY (SEE FIGURE #2A-#2C)

Before connecting to power, the receptacle into which the Packager will be connected should be checked to be certain the voltage and polarity are compatible. If you do not have the technical knowledge or equipment to make this test, your Authorized Brandt Service Representative or a qualified electrician can do it for you. Individual models of this Packager utilize 115 VAC-60HZ -1 PH or 230 VAC-50HZ -1 PH and draw up to 6 AMPS (115 VOLT) or 2 AMPS (230 VOLT) (nominal) during normal operation when utilizing the optional Auto Feed and Crimper. The voltage must be +/-10 percent for proper operation. Compare the voltage measured at the receptacle to the voltage shown on the Rating Plate and the receptacle's polarity to Figure #2A-#2C.

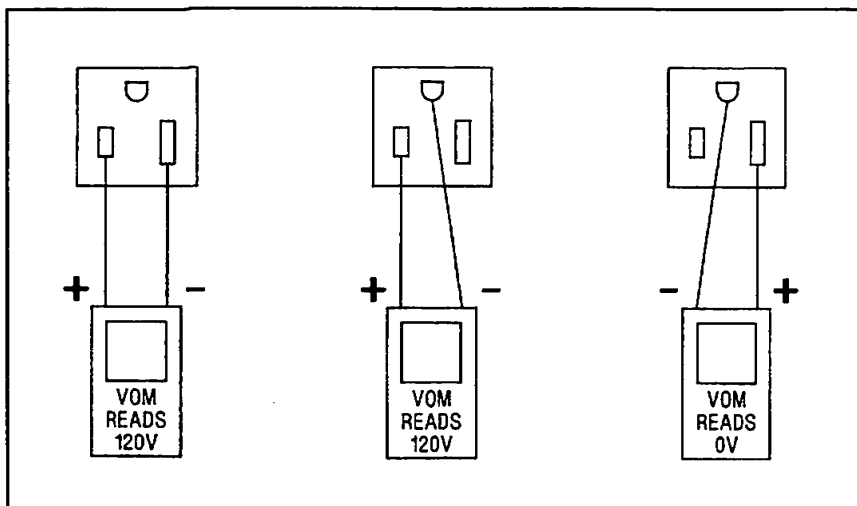

FIGURE #2A

FIGURE #2B
CHECKING POLARITY
(115 VAC SHOWN)

FIGURE #2C

⚠ CAUTION

IF THE VOLTAGES ARE NOT THE SAME, OR THE POLARITY CHECK DOES NOT MATCH FIGURE #2, DO NOT CONNECT THE PACKAGER. REFER THE PROBLEM TO A COMPETENT ELECTRICIAN.

CONNECTING TO POWER (See "SPECIFICATIONS", Page 2)

Connect the appropriate end of the detachable Power Cord into the connector at the rear of the Packager and the opposite end into a GROUNDED outlet of the appropriate voltage.

CAUTION

THIS EQUIPMENT MUST BE GROUNDED FOR PROPER OPERATION. USE OF EXTENSION CORDS OR 3-2 ADAPTERS IS NOT RECOMMENDED. IF A 3-2 ADAPTER IS USED, THE GROUNDING WIRE OR TANG MUST BE CONNECTED TO THE BUILDING GROUND. THE POWER CORD MUST BE DISCONNECTED FROM THE POWER SOURCE BEFORE CLEANING OR SERVICING.

NOTE:

THE PACKAGER CONTAINS INTERNAL PROTECTION AGAINST ELECTRICAL "NOISE"; HOWEVER, IF POSSIBLE, IT SHOULD BE CONNECTED TO A GROUNDED RECEPTACLE THAT IS NOT USED FOR ITEMS THAT CONTAIN BRUSH-TYPE MOTORS, SUCH AS VACUUM CLEANERS, ADDING MACHINES, TYPEWRITERS, ETC.

INSTALLING THE OFFSORT CUP (SEE FIGURE #3)

The Packager will automatically offsort coins smaller than the diameter selected into a small cup located at the front left of the unit. (Larger coins remain on the Disc.) The Offsort Cup is included and is installed by simply pushing it into place, small end first. Offsort Bag Attachment and Dual Bag Spout options are available. Instructions for installation are included with each option.

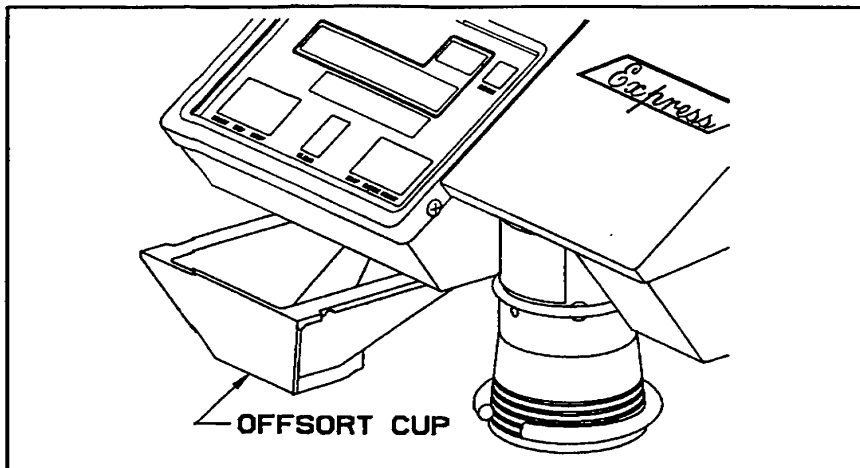

**FIGURE #3
OFFSORT CUP INSTALLATION**

INSTALLING A COIN TUBE (SEE FIGURE #4)

If the Packager is to be used for wrapping, select the proper Coin Tube and (with the Power Switch "OFF") insert it into the Bagging Spout until it "locks."

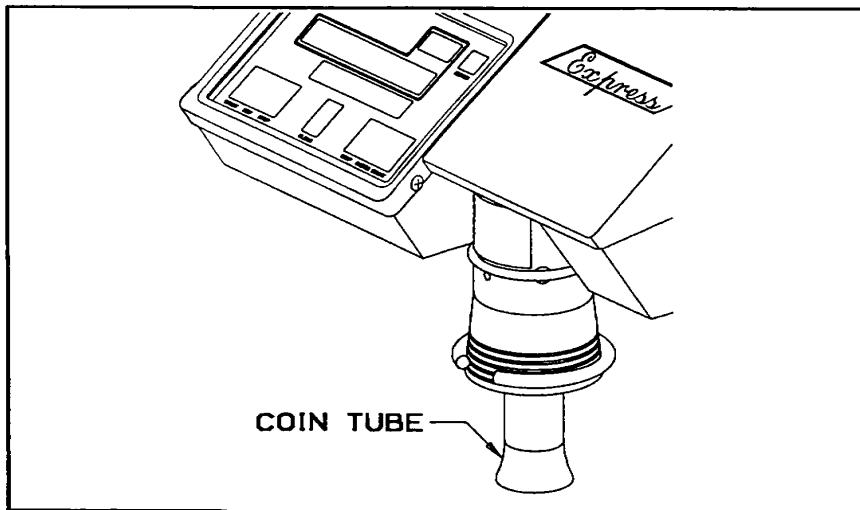

**FIGURE #4
COIN TUBE INSTALLATION**

INSTALLING A COIN BAG (SEE FIGURE #5)

If the Packager is to be used for counting (bagging), attach a Coin Bag onto the Bagging Spout. Lift the ring with the slot facing forward. Slide the Coin Bag between the Bagging Spout and Ring and lower the Ring. As the Bag fills, it will be held progressively tighter by the weight of the coin.

⚠ CAUTION

IF THE PACKAGER IS TO BE USED FOR BAGGING LARGE (HEAVY) QUANTITIES OF COIN, IT SHOULD BE SECURED TO THE SURFACE ON WHICH IT SITS TO PREVENT IT FROM BEING PULLED FORWARD FROM THE WEIGHT OF THE COIN BAG. HOLES ARE PROVIDED IN THE BASE FOR MOUNTING (SEE FIGURE #1).

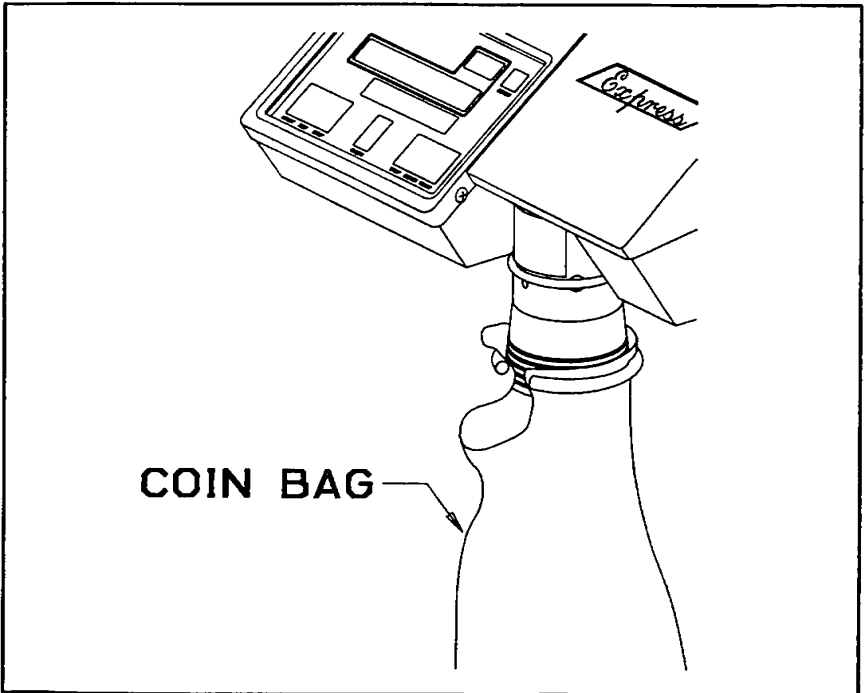

**FIGURE #5
COIN BAG INSTALLATION**

SETTING THE THICKNESS GAUGE (SEE FIGURE #6)

Turn the Ring on the Hopper to correspond to the coin to be processed. The two "pegs" that protrude from the ring act as handles for ease of movement.

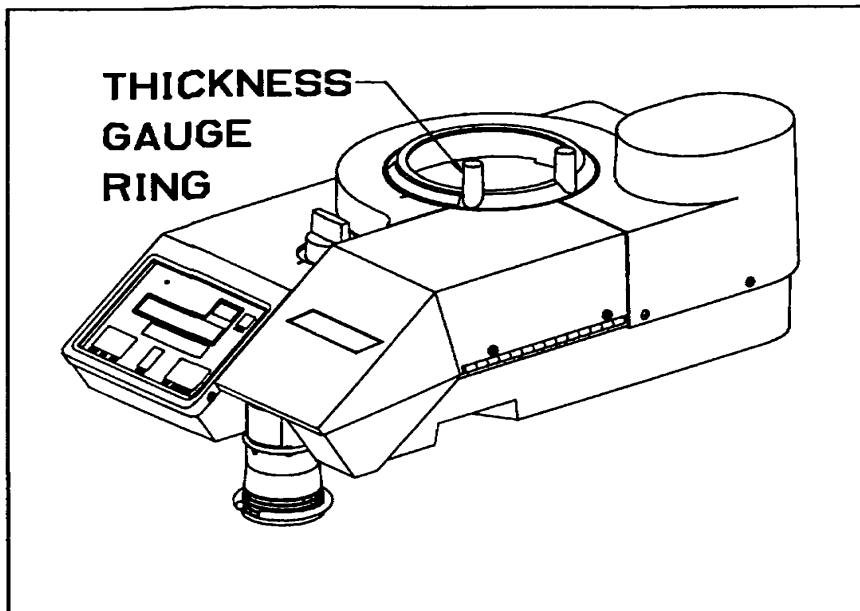

FIGURE #6
THICKNESS GAUGE SETTING

ADDITIONAL INFORMATION

- A. When processing a batch containing half dollars with mixed coins, the Thickness Gauge must be placed at the half dollar ("H") position.
- B. When processing half dollars only, place the Thickness Gauge at the mark to the left of the half dollar ("H") position for most efficient coin flow.
- C. When processing a batch containing nickels and/or SBA dollars mixed with coins, the Thickness Gauge must be placed at the appropriate ("N"—"Q"—"\$") position.
- D. When processing nickels and/or SBA dollars only, place the Thickness Gauge slightly to the left of the ("N"—"\$") position for best coin flow.

SETTING THE DIAMETER GAUGE (SEE FIGURE #7)

Turn the Diameter Gauge Knob to correspond to the coin to be processed.

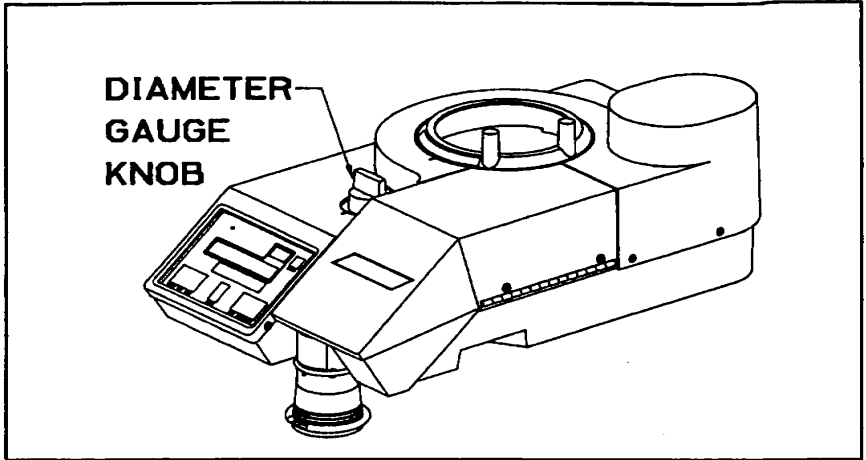
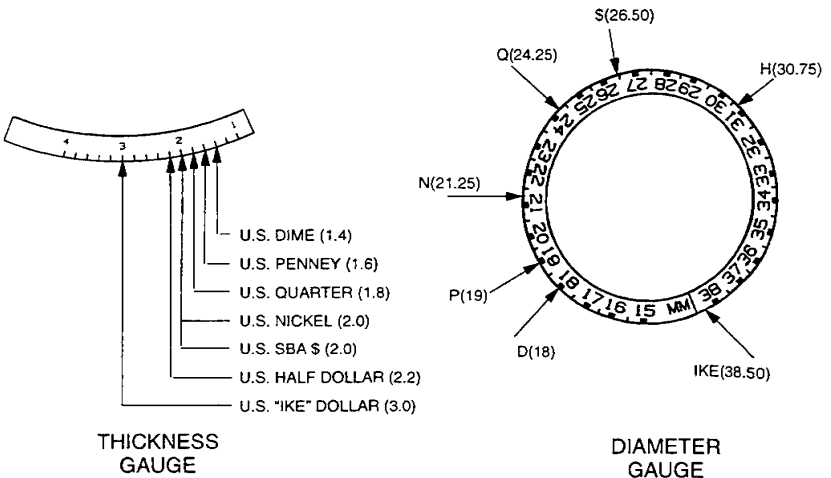

FIGURE #7
DIAMETER GAUGE SETTING

To Process U.S. Coins on a Packager configured for Metric Coins, set the Thickness and Diameter Gauges as shown:



SETTING THE UNIT/DOLLAR SWITCH (SEE FIGURE #9)

A small switch located on the right side of the Control determines the count mode.

NOTE:

TURN POWER OFF BEFORE SWITCHING MODE.
RECORD TOTALS IF NECESSARY.

Slide the switch UP (rearward) if you desire unit count (single count).

Slide the switch DOWN (forward) if you desire the count to be in dollar amount.

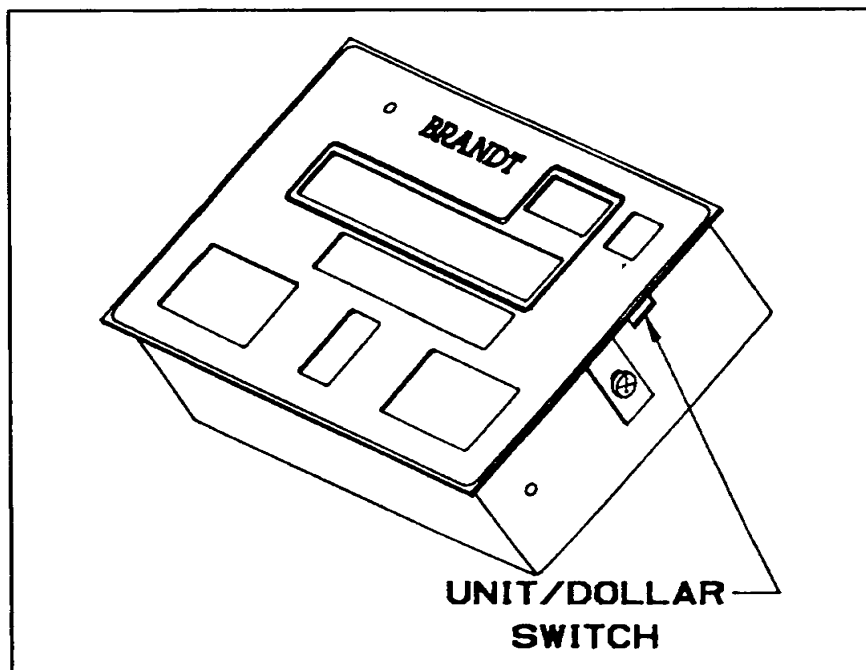

**FIGURE #9
UNIT/DOLLAR SWITCH**

B. THE THREE-DIGIT CONTROL

INTRODUCTION

This Control allows greater flexibility in coin processing to accommodate tokens and coins other than standard U.S.A. In addition, the single unit/dollar switch is replaced with three switches to allow selectability between operational modes (see Figure #11).

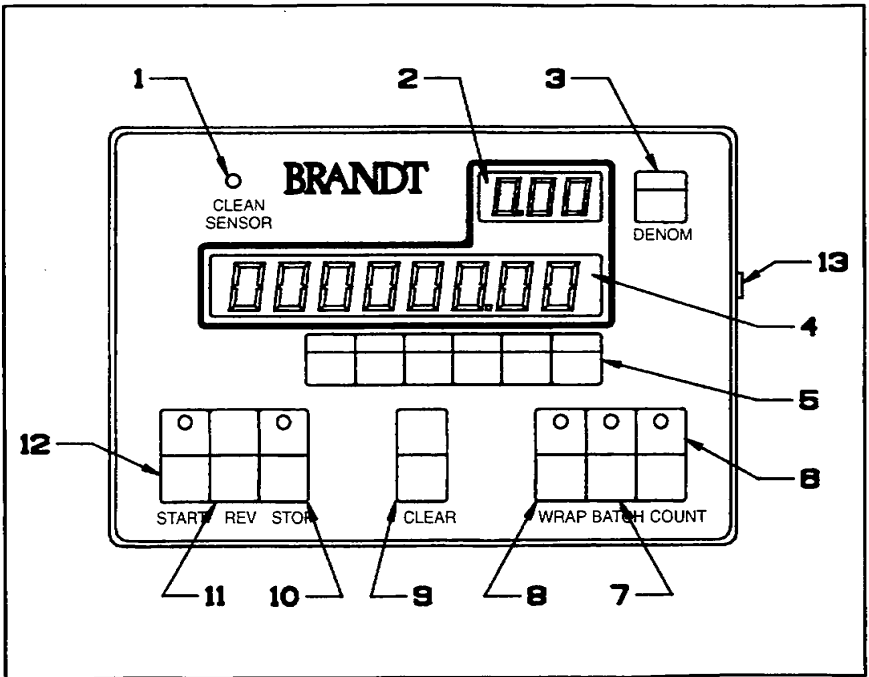

FIGURE #10
THE THREE-DIGIT CONTROL

5. OPERATION

1. The Packager is now prepared for operation. Turn the Power Switch, located at the rear, to "ON". Controls equipped with battery backup will return to the previous operating state prior to power-down. All other Controls will cycle through a "self-check" sequence, momentarily illuminating each digit, and then return to the .01 (penny) position.
2. Set Thickness and Diameter Gauges (Figure #6 and #7).
3. Cycle Denomination Selector Key on the Control to select coin to be processed.

NOTE:

(EXAMPLE) FOR TWO-DIGIT CONTROL ...

- A. SBA \$ REPRESENTED BY 1. INDICATOR.
- B. TOKENS REPRESENTED BY 00 INDICATOR.

(EXAMPLE) FOR THREE-DIGIT CONTROL ...

- A. SBA \$ REPRESENTED BY 1.00 INDICATOR.
- B. TOKENS REPRESENTED BY **1 INDICATOR.

* NO DIGIT ILLUMINATES IN THIS POSITION.

4. Determine operational mode.

NOTE:

AT THIS POINT, IT MUST BE DETERMINED IF THE COINS ARE TO BE COUNTED (VERIFIED), WRAPPED OR BATCHED (BAGGED).

COUNTING/VERIFYING

If the coins are simply to be counted, place a container under the Bagging Spout to collect the coins and press the Start Key. When all the coins have been counted, press the Stop Key and observe the Display to determine the total.

NOTE:

UNITS EQUIPPED WITH A TWO-DIGIT CONTROL WILL STOP AUTOMATICALLY AFTER SEVEN SECONDS OF NO COIN COUNTING IF LEFT UNATTENDED.

UNITS EQUIPPED WITH A THREE-DIGIT CONTROL HAVE THIS FEATURE SELECTABLE (ON OR OFF). SEE FIGURE #11.

WRAPPING

If the coins are to be wrapped, press the Wrap Key and observe the display. The proper number of coins for the denomination being processed will be automatically selected.

Insert a Coin Wrapper into the Coin Tube. Push the Tube gently toward the Packager. The proper quantity of coin will be counted into the Wrapper and the counting will stop.

Crimp the open end of the Coin Wrapper and repeat the process as required.

When the supply of coins is exhausted, if a partial counts remains in "WRAP", hold the Wrap Key down and press the CLEAR Key. On units utilizing a two-digit Control, the display will revert to the preset amount. On units utilizing a three-digit Control, the display will revert to the preset amount if the "downcounting" option is selected, or to "00" if the "upcounting" option is selected (see Figure #11).

The following chart is provided as an aid in determining the number of coins and value per wrap (standard U.S. coins shown).

COIN	UNIT/VALUE
.01 (Penny)	50/\$.50
.05 (Nickel)	40/\$2.00
.10 (Dime)	50/\$5.00
.25 (Quarter)	40/\$10.00
.50 (Half)	20/\$10.00
\$1.00 (Dollar)	25/\$25.00
00 (Token)	Unit Count/00

BAGGING

If the coins are to be batched (bagged), hold the Batch Key down and press the Count Selector Keys to determine the batch quantity.

NOTE:

IF A BATCH SETTING THAT IS NOT DIVISIBLE BY THE DENOMINATION VALUE IS ENTERED, THE MAIN DISPLAY, BATCH INDICATOR AND DENOMINATION DISPLAY DECIMAL POINTS WILL ALL FLASH. THE PACKAGER WILL NOT START. RE-ENTER A DIVISIBLE BATCH SETTING TO PROPERLY SET THE BATCH SETTING.

Release all keys and install a Coin Bag as shown in Figure #5. Press the Start Key. The proper quantity of coin will be counted into the bag and the counting will stop. The display will revert to the preset batch quantity.

When the supply of coins is exhausted, if a partial count remains in "BATCH", add enough coins to complete the batch or hold the Batch Key down and press the CLEAR Key. The display will revert to the preset amount for two-digit controls. For three-digit controls, the display will revert to the preset amount if the "downcounting" option is selected or to "00" if the "upcounting" option is selected (see Figure #11).

NOTE:

MOTOR WILL NOT START IF:

BATCH QUANTITY IS ZERO. BATCH INDICATOR WILL FLASH. PRESS "CLEAR" KEY. ENTER NEW BATCH QUANTITY.

TOKEN DENOMINATION AND WRAP MODE SELECTED ON TWO-DIGIT CONTROL. SELECT "BATCH" AND ENTER NUMBER OF TOKENS TO BE PROCESSED. SPECIAL PROMS ARE AVAILABLE FROM YOUR BRANDT REPRESENTATIVE FOR THE THREE-DIGIT CONTROL TO ALLOW WRAPPING TOKENS.

COUNT TOTALS

Regardless of the mode of operation (Count/Wrap/Batch), coin totals will accumulate as coins are processed, until manually cleared by pressing the "CLEAR" Key. Tokens are added to the total count only in unit count mode.

AUTOMATIC DISC REVERSE

(ALSO SEE "JAM CLEARING", SECTION 6)

The Control will automatically reverse the Motor for 1/2 second whenever no coins pass the Count Sensor for three to four seconds. If the count (coin flow) does not start after the Motor has run for two to three seconds more, the Motor will stop. In addition, the operator can reverse the Motor manually by pressing the Reverse Key on the Control.

AUTOMATIC SHUTDOWN

Units utilizing the two-digit control will automatically stop when no coins of the denomination selected have passed the Count Sensor for seven seconds. The frequency of this occurrence is dependent on the coin mix. To restart, press the Start key. This feature is selectable (on or off) on three-digit Controls (see Figure #11).

6. JAM CLEARING

TRACK AREA THICKNESS GAUGE (FIGURE #12)

In the event of a coin jam that will not self-clear or cannot be cleared by pressing the "REVERSE" Key on the Control, open the Front (Top) Access Door and observe the Coin Track Area.

If additional clearance is required for coin removal, pull forward on the Track Area Thickness Gauge (the item containing the two belts) and tilt upward to the right.

THICKNESS GAUGE (FIGURE #6)

Should the coin jam be located in the Thickness Gauge Area, the gauge may be rotated counterclockwise (opened) for additional clearance. The "pegs" that protrude from the top of the gauge act as "handles" for that purpose.

NOTE:

BE SURE NO COINS REMAIN UNDER THE THICKNESS GAUGE WHEN IT IS RESET TO ITS PROPER OPERATING POSITION.

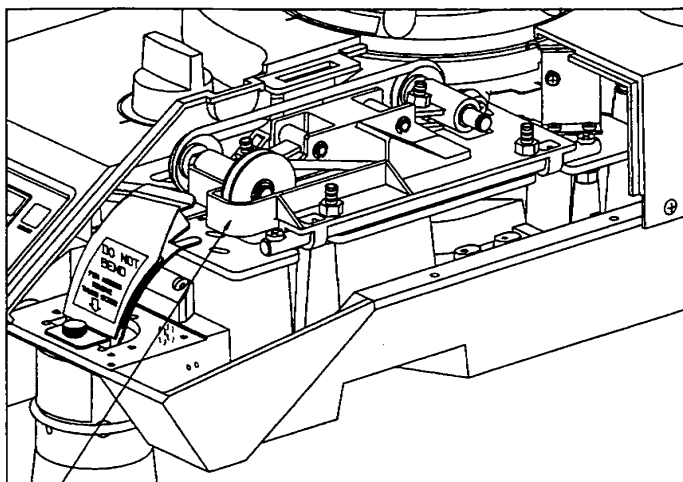

PULL TRACK AREA THICKNESS GAUGE FORWARD, TILT UPWARD TO THE RIGHT FOR ADDITIONAL ACCESS

**FIGURE #12
RELEASING A JAM**

7. BENT OR MUTILATED COINS

Badly bent or mutilated coins should not be processed through the Packager as they may stick or jam, slowing the coin flow and possibly causing damage! Inspect the coins as they are fed through the Packager and remove those that are suspect.

8. TROUBLESHOOTING GUIDE

NOTE:

THE FOLLOWING TROUBLESHOOTING GUIDE IS PROVIDED FOR YOUR ASSISTANCE IN DETERMINING THE CAUSE/SOLUTION TO POSSIBLE PROBLEMS. ALWAYS RECORD TOTALS AND THEN DISCONNECT THE PACKAGER FROM POWER BEFORE ATTEMPTING REPAIR OR DISASSEMBLY. CONTACT YOUR BRANDT AUTHORIZED SERVICE REPRESENTATIVE IF A PROBLEM PERSISTS.

PROBLEM	POSSIBLE SOLUTIONS
No Functions	<ol style="list-style-type: none"> 1. Be sure Packager is connected to power. 2. Blown Fuse(s)(investigate cause)
Disc will not turn.	<ol style="list-style-type: none"> 1. Coins(s) jammed under Thickness Gauge. 2. Tripped Circuit Breaker. 3. Broken Drive Belt.
Coins will not Exit	<ol style="list-style-type: none"> 1. Bent or jammed coin or other article blocking coin path. 2. Coin Thickness or Diameter Gauge set on wrong coin. 3. Ejector Belt broken.
All Coins go to Offsort Chute	<ol style="list-style-type: none"> 1. Diameter Gauge set on wrong coin.
Coins Process, but will not Count	<ol style="list-style-type: none"> 1. Unplugged or defective Count Sensor. 2. Defective Electronics (Control).
Illuminated "Clean Sensor" Indicator	<ol style="list-style-type: none"> 1. Clean Count Sensor.
"E6" Shown on Display at powerup (Three-Digit Controls Only)	<ol style="list-style-type: none"> 1. Press "CLEAR" Key (may require two depressions). If problem persists, contact your Authorized Brandt Service Representative for Battery Replacement.

9. OPERATOR MAINTENANCE



DISCONNECT POWER CORD BEFORE CLEANING!

CLEANING THE COUNT SENSOR

When the Count Sensor, located at the front of the Coin Track, becomes too dirty to allow accurate counting, the Packager will stop and the "Clean Sensor" LED Indicator on the Control will come on and remain on constantly until the Sensor is cleaned and the START Key is pressed. The Packager cannot be restarted if the Count Sensor remains dirty (Indicator on). Using a soft bristle brush, clean the Sensor and Coin Track of coin dust or other articles that may be blocking the Sensor, then resume normal operation.

RESETTING THE CIRCUIT BREAKERS (SEE FIGURE #13)

Two Circuit Breakers are utilized.

115 VAC Units

- A. (CB1) Six (6) AMP for Control.
- B. (CB2) Three-quarter (.75) AMP for Motor.

230 VAC Units

- A. (CB1) Two (2) AMP for Control.
- B. (CB2) (CB3) One-quarter (.25) AMP for Motor.

If a Circuit Breaker should trip, locate and eliminate the cause, then push in on the center button to reset.

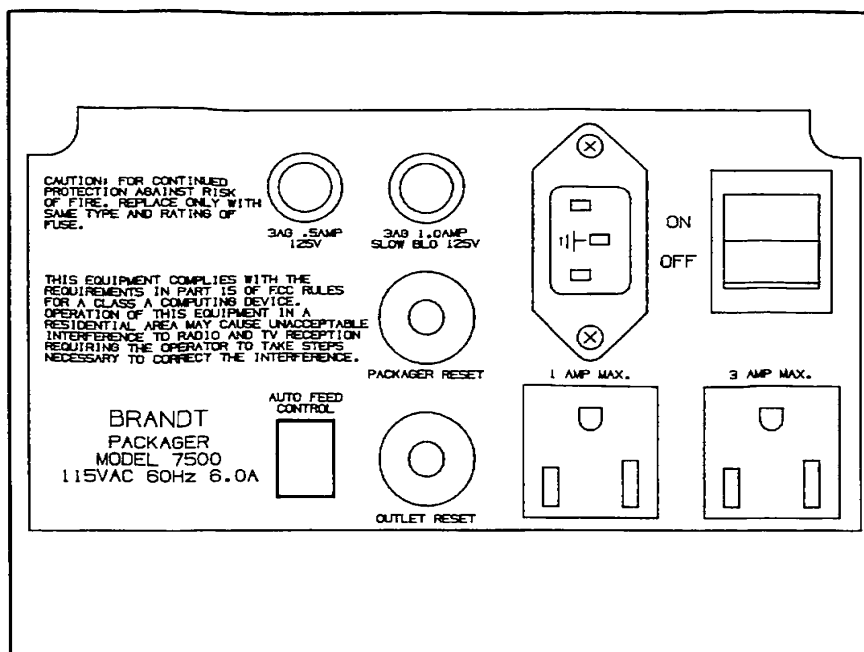

**FIGURE #13
CIRCUIT BREAKERS/FUSES
(115 VAC MODEL 7500 SHOWN)**

REPLACING THE FUSES (SEE FIGURE #13)

Two fuses are utilized:

115 VAC Units

- A. One (1) AMP (SLO-BLO) – Transformer (F1).
- B. One-half (1/2) AMP – Control Power Supply (F2).

230 VAC Units

- A. One-Half (1/2) AMP (SLO-BLO) – Transformer (F1) (F2).
- B. One-Half (1/2) AMP – Control Power Supply (F3).

CAUTION

ALWAYS REPLACE FUSES WITH EXACT TYPE AND RATING FOR CONTINUED PROTECTION. FUSES ARE AVAILABLE LOCALLY OR THROUGH YOUR AUTHORIZED BRANDT SERVICE REPRESENTATIVE.

REPLACING THE EJECTOR BELT (SEE FIGURE #14)

Open the Access Cover. Lift the Pivot Arms to relieve the belt tension. Exchange the Belt and push the Pivot Arms down. Normal Belt Tension will hold the Belt in position.

NOTE:

REPLACEMENT BELTS ARE AVAILABLE THROUGH YOUR AUTHORIZED BRANDT SERVICE REPRESENTATIVE.

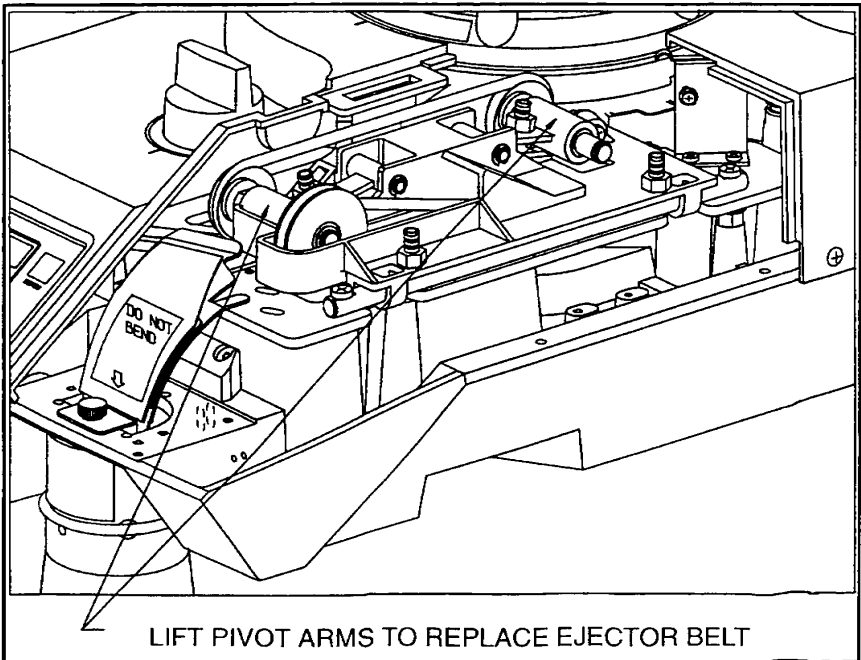

**FIGURE #14
EJECTOR BELT REPLACEMENT**

10. CARE OF THE PACKAGER

The Packager should be kept clean, free of dirt, dust and other foreign articles that may affect its performance or cause jams or other damage. The outside surfaces should be cleaned with a soft cloth and mild soap and water. **NEVER USE HARSH CLEANERS OR CLEANSERS ON THE OUTSIDE SURFACES.**

The Rotating Disc and Coin Track areas should be cleaned periodically (frequency varies with use) with alcohol to remove dirt deposits (use alcohol sparingly).

It is recommended that the Packager be turned off for protection when not in use.

NOTE:

MODELS USING A TWO-DIGIT CONTROL WILL RESET COUNT TOTALS TO ZERO WHEN POWER IS TURNED OFF. SOME MODELS USING A THREE-DIGIT CONTROL UTILIZE BATTERY BACKUP CIRCUITRY TO RETAIN THE TOTALS IN THE EVENT OF A POWER INTERRUPTION OR LOSS.

This product was designed for ease of operation and service. Always observe common safety practices (no long hair, neckties, loose clothing, etc.) when operating, and always disconnect the Packager from the power source before cleaning. Contact your Authorized Brandt Service Representative for assistance.

BRANDT[®]

A De La Rue Company



705 S. 12th Street

Box 200

Watertown, WI 53094-4006

(414) 261-1780 Fax: (414) 261-8597

Audix (Voicemail): (414) 262-3377