



# DEFENDER USER MANUAL



- Interchangeable with existing Comparator<sup>®</sup> mechanisms
- Uses independent diameter sensing that discriminates shaved coins or tokens
- An array of sensors track the passage of the coin from the moment it enters the Defender until it exits
- Micro controller based technology performs coin analysis and I/O functions
- Fixed credit buffering
- Bi-color LED status indicator
- Accurate coin counting at a feed rate up to 1 coin every 50 milliseconds
- All mechanisms 100% coin tested before shipment
- Socketed micro for easy upgrades
- Multiple Defender part numbers cover coin diameters of .698" / 17.73 mm (U.S. Dime) through 1.875" / 47.60mm.
- Dynamic coin path sensing can determine if a validated coin changes direction.
- Coin Mechanisms, Inc. proprietary coin path sensor.
- An output (Ready) indicates the operating status of the mechanism, and operates in conjunction with the Bi-colored LED.
- Optic emulation capabilities.
- High or Low logic Inhibit available

# DEFENDER

## BASIC THEORY OF OPERATION

### BASIC THEORY OF OPERATION:

The DEFENDER is an Electromechanical Coin Mechanism designed to accept a single denomination metal coin. The DEFENDER must be mounted in an up-right position so that gravity pulls a coin downward through the mechanism.

The mechanism has a single top coin entry slot located on the top left side. There are two coin exits at the bottom of the mechanism. In a normal straight drop unit an accepted good coin exits the mechanism on the left side, directly below the top entry slot, and rejected bad coins exit on the right side. In a reverse logic mechanism, an accepted good coin exits the mechanism on the bottom right side, the side opposite of the top entry slot.

Inside the mechanism there is an Accept Gate. If a valid good coin is detected, the Accept Gate is opened allowing the coin to fall out the bottom of the unit on the accept side. In reject mode, a bad coin is deflected by the Accept Gate and falls out of the bottom of the mechanism on the reject side.

A representative sample of the coins that are to be accepted by the Comparitor must be placed in a special slot in the magnetic sensor coils. This coin, and location, is referred to as the resident coin. The diameter of the resident coin and the rail adjustment screw sets the drop slot width. The metal in the resident coin is used to compare against the metal of coins falling through the mechanism.

The main circuit board in the DEFENDER interfaces with the Host Machine and Sensors located in the Mechanism. A microcontroller on the main circuit board is controlled by special software that analyzes inputs from the sensors, controls the Accept Gate, and issues the appropriate signals to the customer interface.

When a coin is dropped into the DEFENDER Mechanism, a microcontroller on the main PC board checks for specific events to occur in the proper sequence for a proper length of time and then performs certain actions based upon the event sequence.

#### NORMAL Event / Action Sequence.

=====

- 1) Event: Detect valid coin
- 2) Action: Open the Accept Gate and Issue Sense Pulse
- 3) Event: Detect coin exiting the mechanism
- 4) Action: Issue Credit Pulse and Close the Accept Gate

The Mechanism will automatically enter a TILT Mode if a sensor is blocked for too long, or if an improper sequence of events is detected.

There is an Inhibit input on the Mechanism that will stop the unit from accepting coins when active.

# Coin Mechanisms Inc. Defender part number Selection Guide

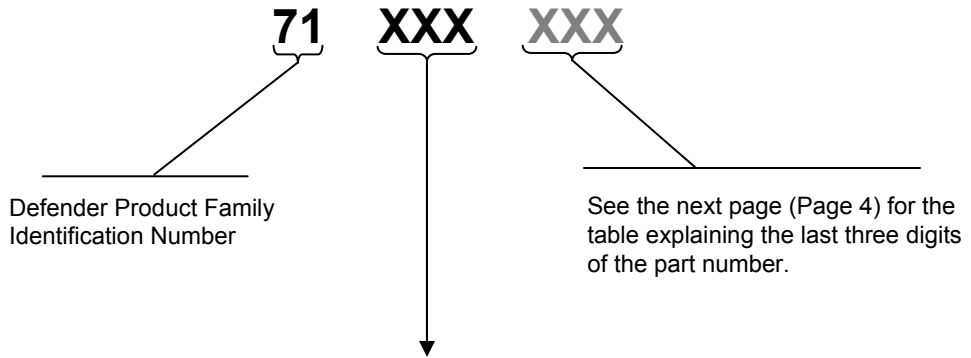

Machine Mfr.	Replaces	Firmware ID #		Interface Harness
		(Small Coin)	(Large Coin)	
Aristocrat	Model 62	005	006	0928-000117
Bally	Model 16OE	007	008	0928-000149
Bally	Model 62	005	006	0928-000117
IGT	Model 16 (80960 platform)	001	002	0928-000116
Konami	Model 40	009	010	0928-000117
Sigma	Model 16	009	010	0928-000115
Sigma	Model 16OE	011	012	0928-000117
Sigma	Model 40	013	014	0928-000126
WMS	Model 16	009	010	0928-000115
WMS	Model 40OE	003	004	0928-000117
Unidesa	Model 62	005	006	0928-000117
Universal	Model 62	005	006	0928-000117
IGT	Model 36	N/A	015	0928-000116

e.g. Coin Mechanisms Inc part number 71001013 is a Defender that will accommodate a U.S. 25 cent coin (0.955" x .069") for use in an IGT machine.

**Note:** Coin Size Description  
 Small coin = .698 - 1.250 diameter  
 Large coin = >1.250

# Coin Mechanisms Inc. Defender part number Selection Guide

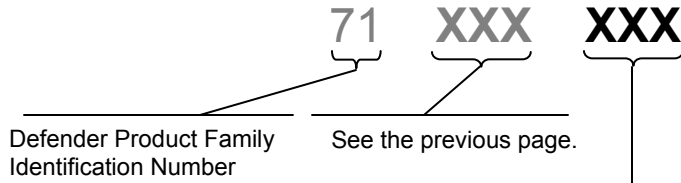

Mechanical ID #	Diameter Range in. (mm)	Thickness Range in. (mm)	Exit Spacer	Body Style
012	0.698 - 1.050 (17.7 - 26.6mm)	0.050 - 0.065 (1.27 - 1.66mm)	Y	Straight Drop
013	0.698 - 1.050 (17.7 - 26.6mm)	0.066 - 0.085 (1.67 - 2.16mm)	Y	Straight Drop
014	0.698 - 1.050 (17.7 - 26.6mm)	0.086 - 0.125 (2.13 - 3.17mm)	Y	Straight Drop
015	1.051 - 1.250 (26.7 - 31.7mm)	0.066 - 0.083 (1.67 - 2.16mm)	N	Straight Drop
016	1.051 - 1.250 (26.7 - 31.7mm)	0.086 - 0.125 (2.13 - 3.17mm)	N	Straight Drop
017	1.251 - 1.500 (31.8 - 38.1mm)	0.066 - 0.085 (1.67 - 2.16mm)	N	Straight Drop
018	1.251 - 1.500 (31.8 - 38.1mm)	0.086 - 0.125 (2.18 - 3.17mm)	N	Straight Drop
019	1.501 - 1.875 (38.1 - 47.6mm)	0.098 - 0.145 (2.4 - 3.68mm)	N	Reverse Logic
020	1.501 - 1.875 (38.1 - 47.6mm)	0.098 - 0.145 (2.4 - 3.68mm)	N	Wide Body
021	1.501 - 1.875 (38.1 - 47.6mm)	0.066 - 0.097 (1.67 - 2.46mm)	N	Reverse Logic
022	1.501 - 1.875 (38.1 - 47.6mm)	0.066 - 0.097 (1.67 - 2.46mm)	N	Wide Body

**Note:** For specific parameters of each firmware, contact Coin Mechanisms Inc customer service department.

If a coin / token dimensional parameters fall on the thickness or diameter transition point of the Mechanism, always choose the Mechanism with the larger dimensional specifications.

# DEFENDER

## Mechanical Specification

---

### Mounting:

Within 3 degree of vertical

---

### Drop Slot:

- The drop slot width is determined by the coin inserted as the resident coin. The resident coin must be typical of the population of coins you want to accept. Do not use damaged, bent or excessively worn coin as a resident coin.
- The drop slot width, or Diameter sensitivity, is fine tuned by adjusting the .050" hex set screw in the side rail.
- The coin/token must be delivered into the Defender drop slot within 6 degrees of vertical.

### Drop Slot Alignment to Host Machine:

- In order to alleviate shingling of coins within the mechanism (and avoid jam conditions), the drop slot width (coin thickness gap) is tightly controlled for ranges of coin thicknesses. This gap is maintained throughout the mechanism.
- Coin head alignment to the Defender drop slot is crucial for proper operation. Misalignment can cause coin jams at entry, coin delay causing Tilts, or erratic operation. Coins must be delivered into the mech opening within 6 degrees of vertical to prevent fast feed jams at this opening.
- It is imperative that the host machine deliver coins into the Defender by referencing the centerline of the mounting studs to the inside surface of the metal mainplate. This .25" / 6.3mm reference dimension has not changed since mechanical mechanism usage. This alignment dimension is important because the reference is the same regardless of the drop slot gap that is available in different Defender models. This fixed reference is shown in the Defender mechanical specification section of the manual.

### Resident Coin Insertion:

- The resident coin is used to "program" the Defender to accept that coin. The resident coin also automatically sets the drop slot diameter clearance and sensor positions.
- The sliding Sensor Coil Assembly allows a wide range of diameter coins to be used without the need to add or change parts to the mechanism.
- It is important for the resident coin to be centered in its rest position relative to the Sensor Coil. The resident coin rests in a small notch on each side of its horizontal centerline. A self aligning guide designed into the side walls will roll most resident coins into this proper location. Some coins may be difficult to "self align". Manually position these coins so they rest in the notch centerline. A resident coin that is not positioned properly will most likely reject good coins.

### Rail adjustment:

- A coin representative of the desired coin population is placed in residence.
- The rail adjustment is adjusted to accept 100% of the coins that match the resident coin.
- The diameter detection optics are designed to ACCEPT falling coins that are up to .010" / .254mm smaller in diameter than the maximum diameter coin that the drop slot is set for.
- The diameter detection optics are designed to REJECT falling coins that are greater than .040" / 1.016mm (smaller) in diameter than the maximum diameter coin that the drop slot is set for.

### NOTE:

The diameter sensitivity set screw must never be turned more than 3/4 turn clockwise from its initial factory setting to prevent damage to this assembly.

# DEFENDER Standard Body Straight Drop Front View with resident coin

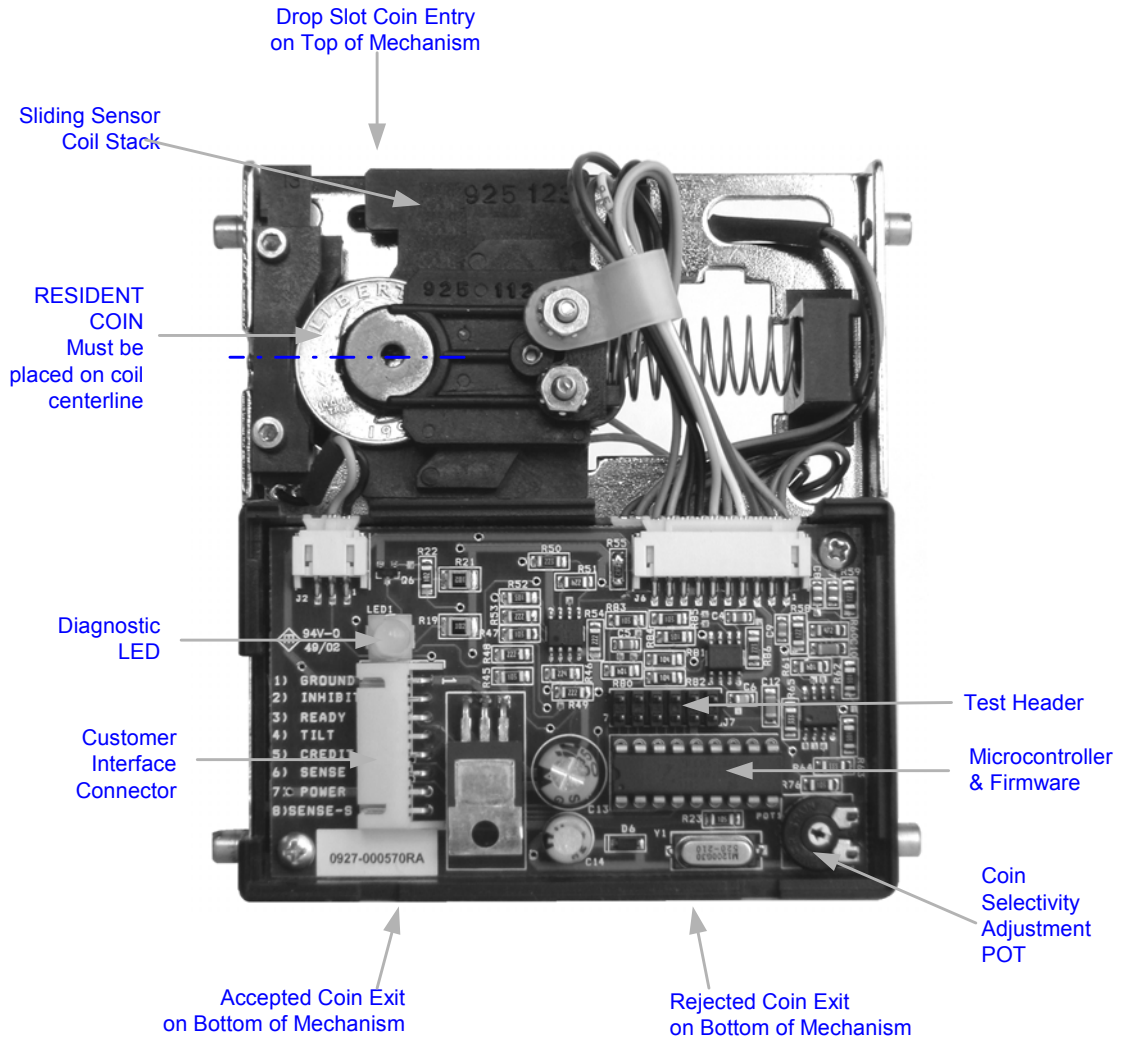

## Coin Exit Spacer

An exit spacer is available for mounting inside the accept side coin exit. This spacer will limit coins to 1.050" maximum diameter. The Defender does not need an exit spacer for proper operation.

The exit spacer is used in machines requiring the exiting coin to better align with the machine optics and prevent nuisance Tilts.

The exit spacer is easily installed or removed with a single screw on the back side of the mainplate.

# DEFENDER

## Standard Body Straight Drop Mechanical Specification

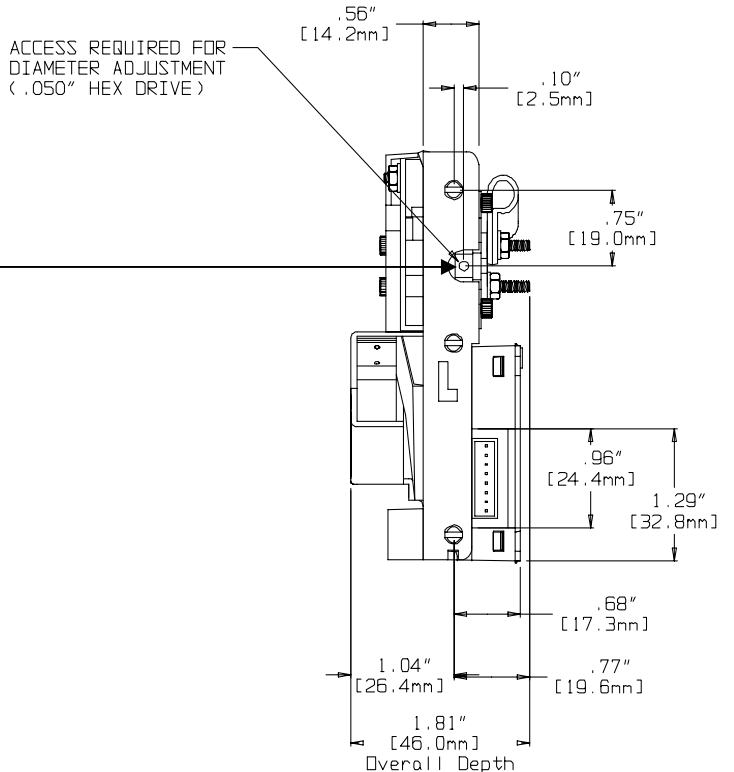
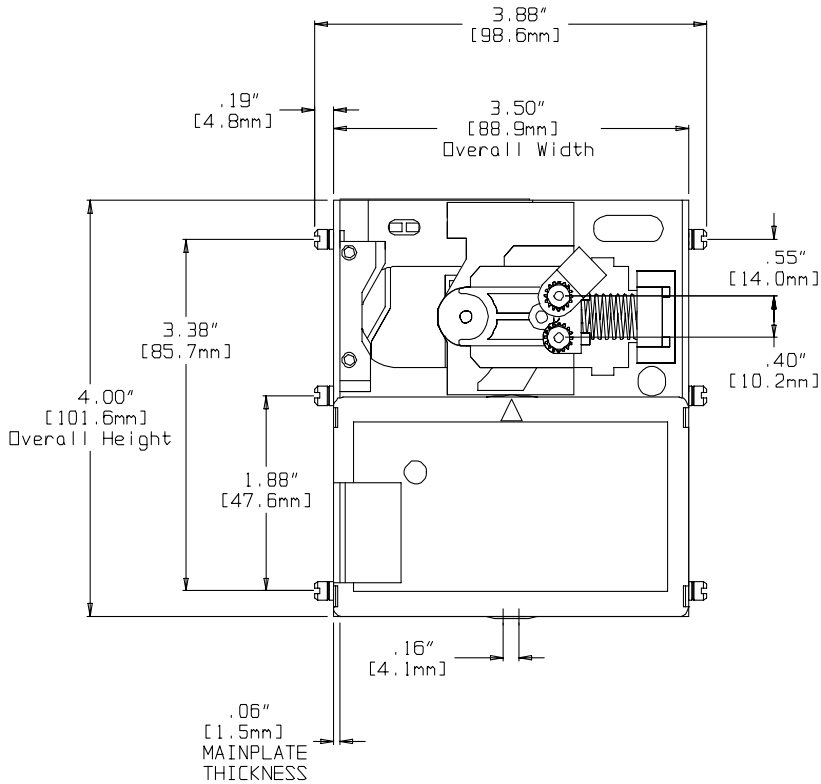

Counter clockwise adjustment of set screw reduces diameter clearance in drop slot. Clockwise increases clearance  
A 1/4 turn of this screw changes diameter clearance by approximately .006" (.152mm)

# DEFENDER

## Standard Body Reverse Logic Mechanical Specification

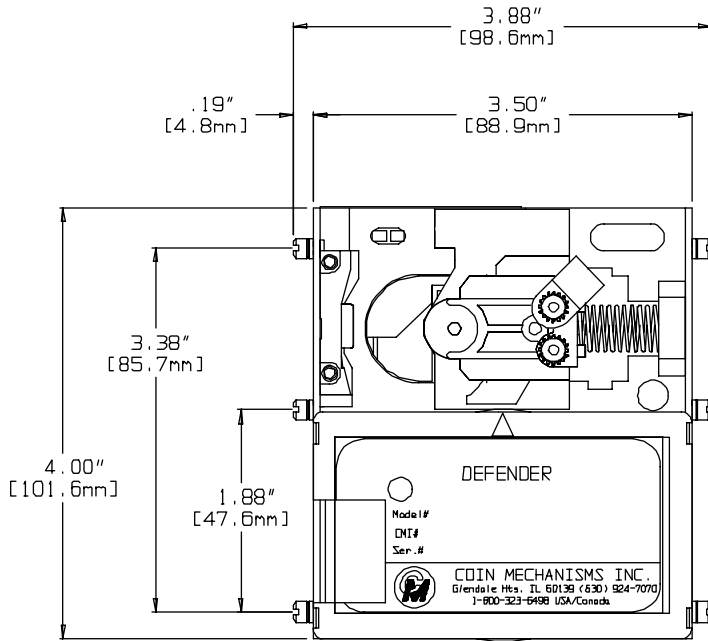

ACCESS REQUIRED FOR  
DIAMETER ADJUSTMENT  
(.050" HEX DRIVE)

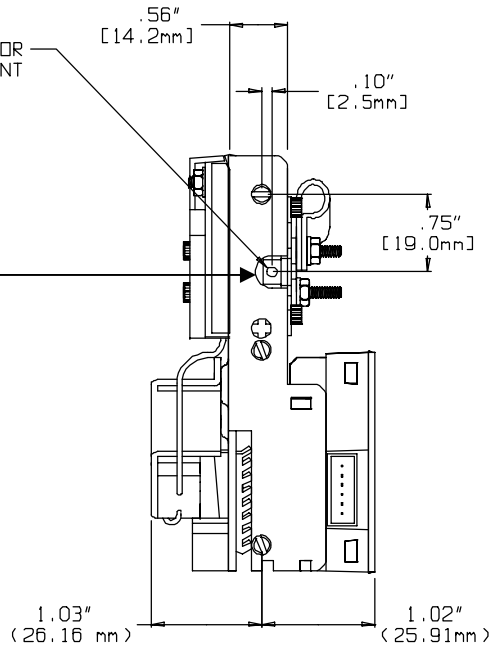

Counter clockwise adjustment  
of set screw reduces diameter  
clearance in drop slot. Clockwise  
increases clearance  
A 1/4 turn of this screw changes  
diameter clearance by  
approximately .006" (.152mm)



# DEFENDER

## Straight Drop Wide Body Mechanical Specification

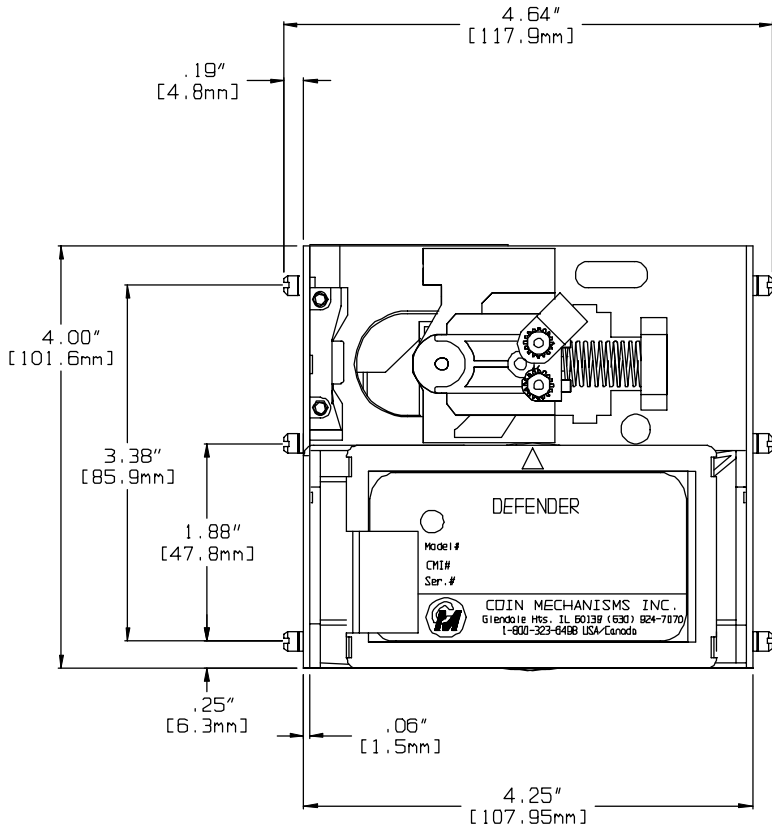

Counter clockwise adjustment of set screw reduces diameter clearance in drop slot. Clockwise increases clearance  
A 1/4 turn of this screw changes diameter clearance by approximately .006" (.152mm)

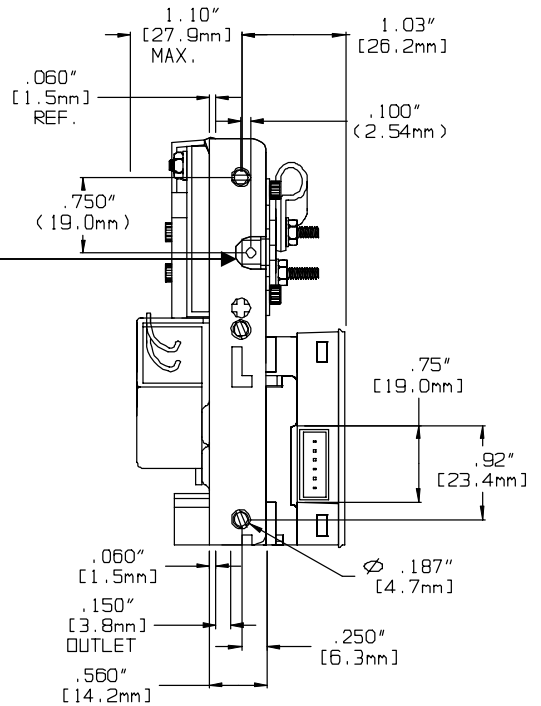

# DEFENDER

## Standard Body Straight Drop with exit spacer Mechanical Alignment Specification

Mechanical Dimension for mechanical fit only NOT COIN DIAMETER RANGE

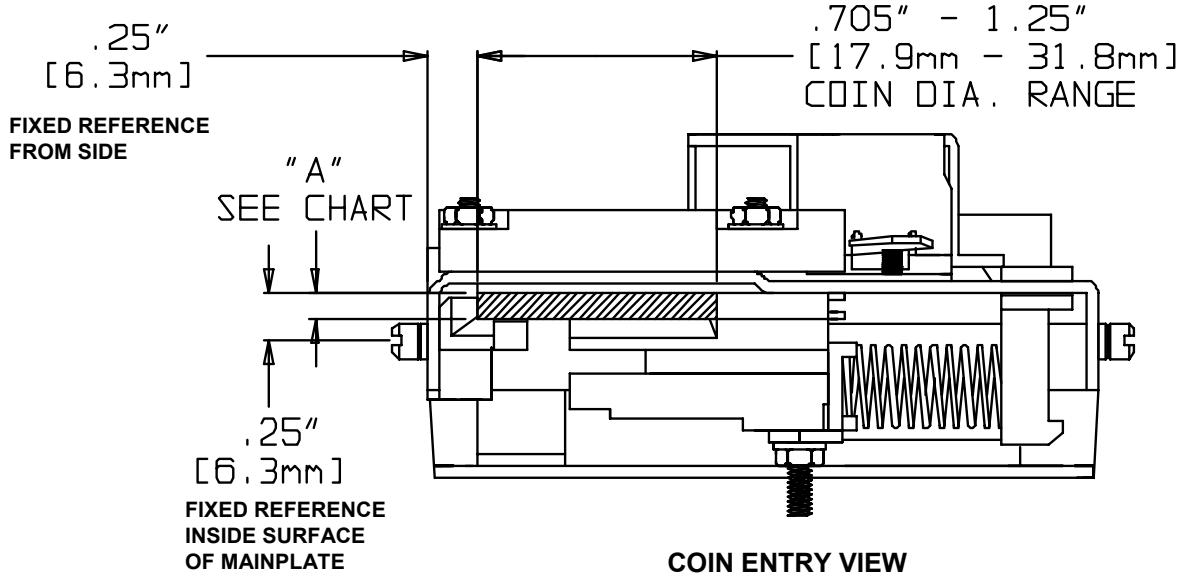

**Gap thickness for Defender units with exit spacer**

Defender Model Description 71 XXX XXX	Entry "A"	EXIT "B"
012	.085 in / 2.16 mm	.090 in / 2.29 mm
013	.102 in / 2.59 mm	.090 in / 2.29 mm
014	.130 in / 3.30 mm	.130 in / 3.30 mm

Mechanical Dimension for mechanical fit only NOT COIN DIAMETER RANGE

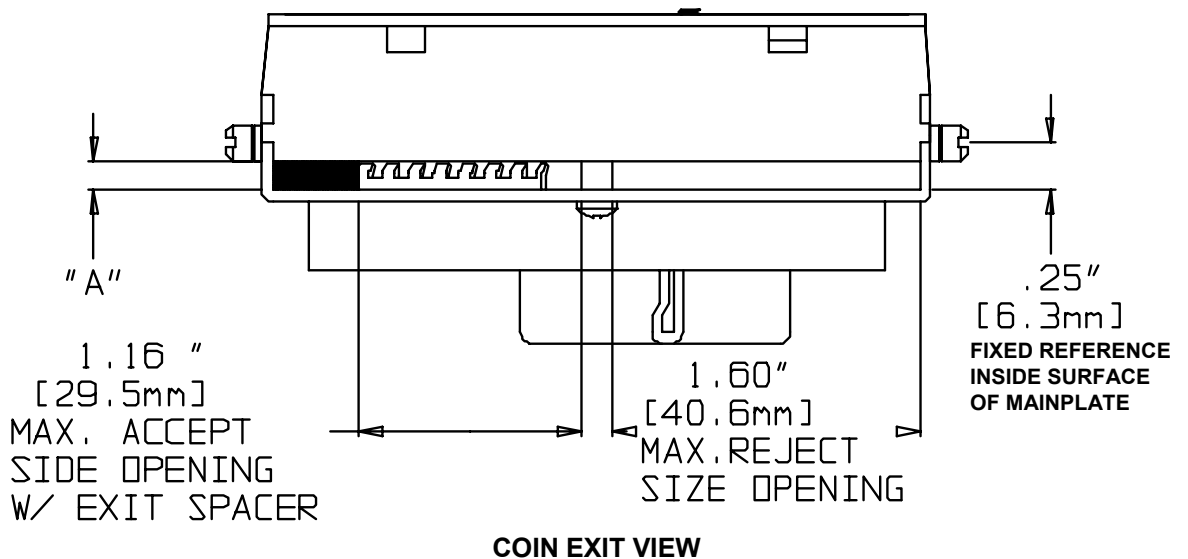

# DEFENDER

## Standard Body Straight Drop

### Mechanical Alignment Specification without exit spacer

Mechanical Dimension for mechanical fit only NOT COIN DIAMETER RANGE

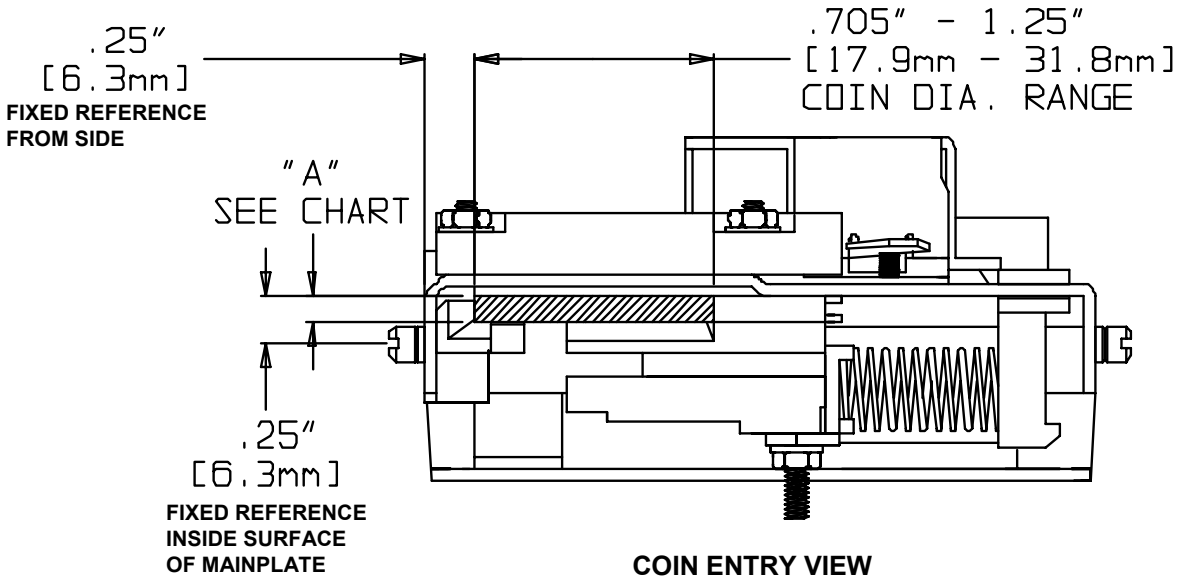

Gap thickness for Defender units without exit spacer

Defender Model Description 71 XXX XXX	Entry "A"	EXIT "B"
015 , 017	.102 in / 2.59 mm	.090 in / 2.29 mm
016 , 018	.130 in / 3.30 mm	.130 in / 3.30 mm

Mechanical Dimension for mechanical fit only NOT COIN DIAMETER RANGE

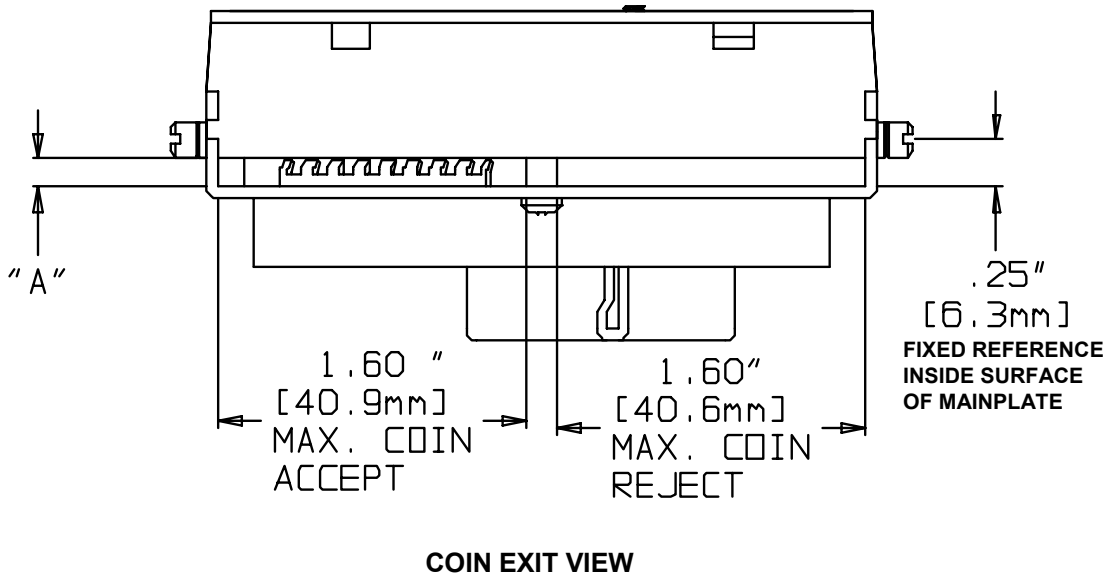

# DEFENDER

## Standard Body Reverse Logic

### Mechanical Alignment Specification

Mechanical Dimension for mechanical fit only NOT COIN DIAMETER RANGE

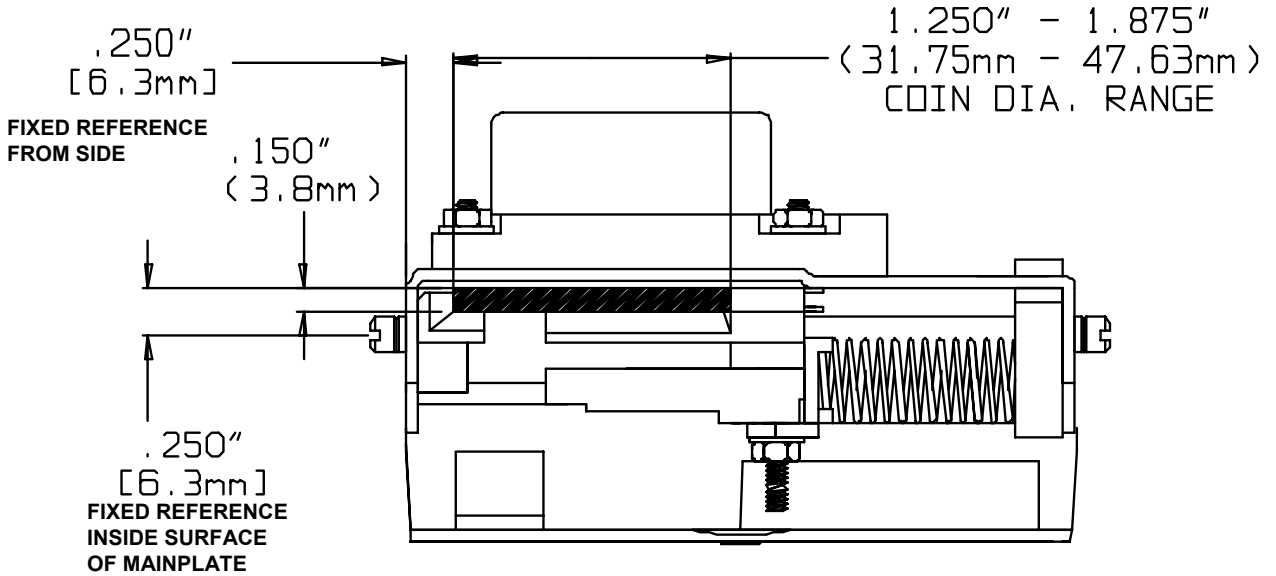

**COIN ENTRY VIEW**

Mechanical Dimension for mechanical fit only NOT COIN DIAMETER RANGE

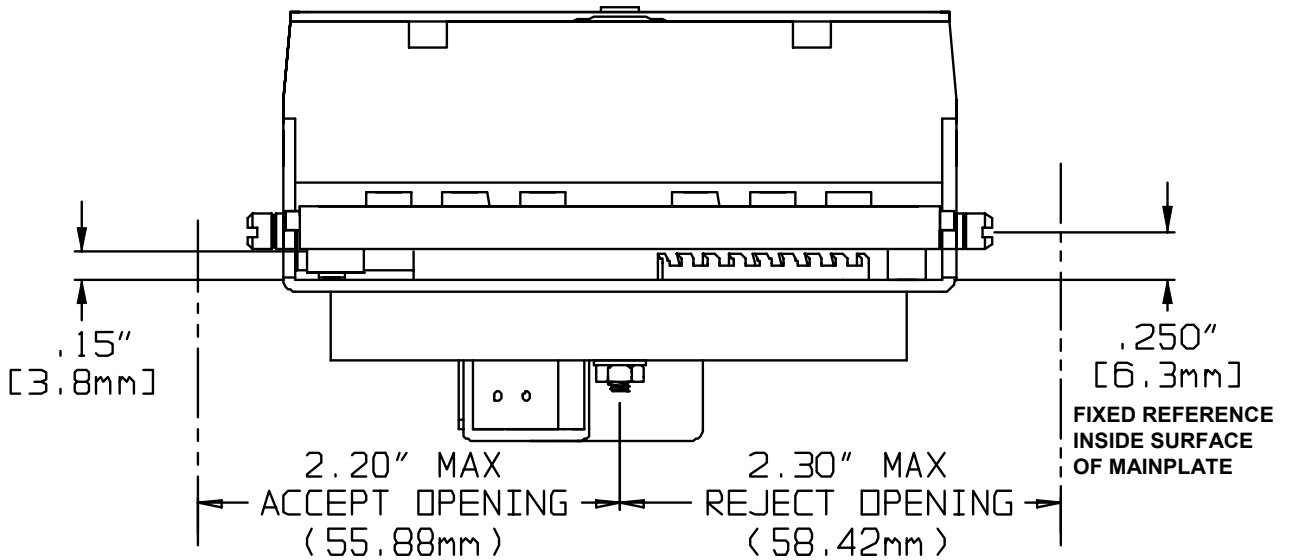

**COIN EXIT VIEW**

# DEFENDER

## Straight Drop Wide Body

### Mechanical Alignment Specification

Mechanical Dimension for mechanical fit only NOT COIN DIAMETER RANGE

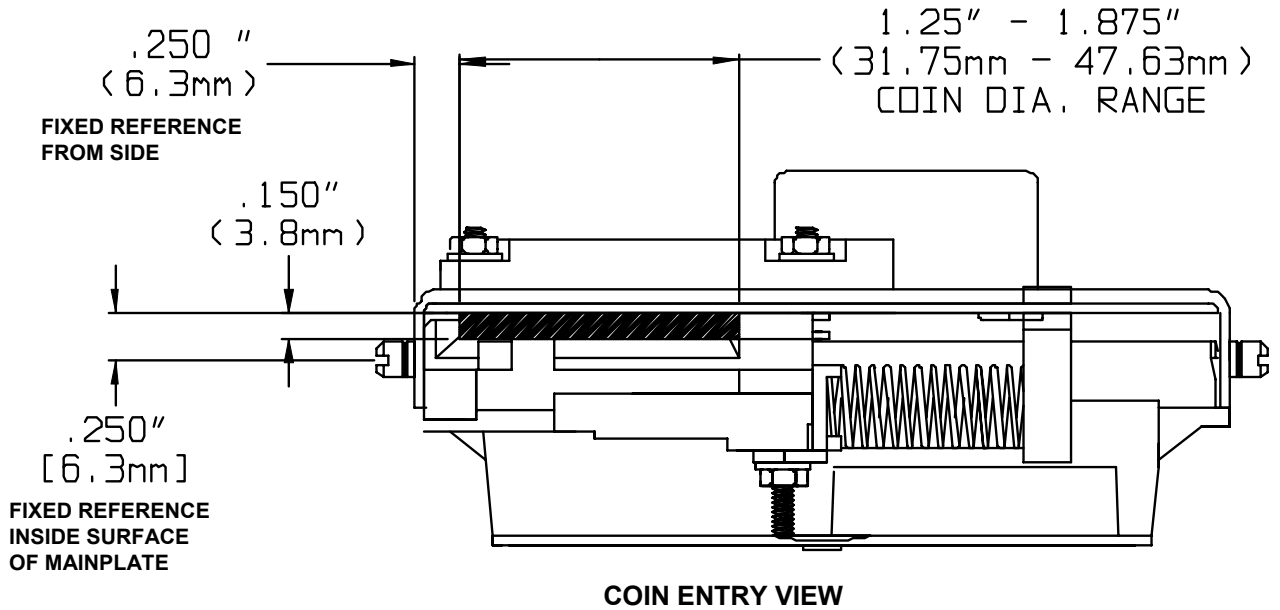

Mechanical Dimension for mechanical fit only NOT COIN DIAMETER RANGE

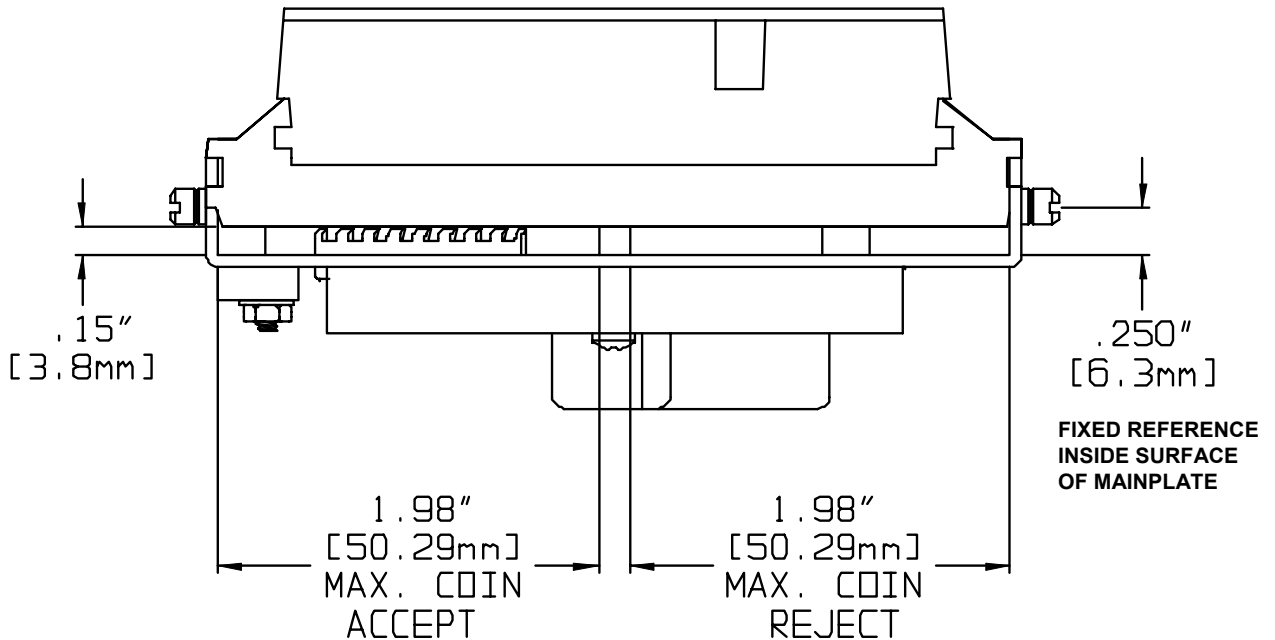

**COIN EXIT VIEW**

# DEFENDER

## INITIAL Configuration and Set-Up

The mechanism will ship from Coin Mechanisms in a normal operating configuration. It may be necessary for the end user to make some special adjustments for their application.

Before installing the mechanism and powering it up the end user must:

- 1) Insert a sample coin in the resident coin location.

Note: When changing coin denominations, it may be necessary to adjust the rail adjustment screw.

- 2) Adjustment of the coin path diameter by using the rail adjustment screw :

Drop a coin, identical to the sample coin, through the Sense coils while turning the rail set screw counterclockwise until Test coin(s) stops in the Sensor coil. \*Slowly turn set screw clockwise until the stopped coin falls through the mechanism. Drop more test coins and continue adjusting the rail set screw until all of the test coins drop completely through the mechanism. Turn screw an additional 1/4 turn for diameter clearance, verify all good coins are accepted by the mechanism. Never turn screw more than 3/4 turn clockwise beyond initial minimum diameter clearance.

\* If you cannot stop the test coin(s) in the Sensor coils, your resident coin may be greater than .009" in diameter than your test coins or your resident coin is not seated properly in the holder notch. Select a more typical size resident coin.

During Installation:

- 1) Connect an appropriate Cable to the 8-pin Customer Interface J1.
- 2) Apply 12VDC Power and make sure GREEN LED comes ON.
- 3) Drop valid coins through the unit and make sure they are properly accepted.

After Installation, During Normal Operation:

- 1) Adjust coin selectivity POT.

Periodic Maintenance:

- 1) Make sure unit is Clean  
No dust, dirt, or debris, has accumulated in the mechanisms drop slot.
- 2) Check Coil Balance.
- 3) Check Side Rail diameter Adjustment.

**TOOLS REQUIRED**

- 1) 0.050" Hex Wrench to adjust the Side-Rail Set Screw (CMI# 05090023).
- 2) 1/16 Hex Wrench to adjust Coil Balance (CMI # 05090004).
- 3) 3/32 Hex Wrench for Sensor Coil stack screws and Rail Assembly.
- 4) #1 Phillips Screwdriver to remove Main PC Board.
- 5) #1 Flat Blade (2.0mm) Screwdriver to Set Pot on Main PC Board
- 6) 1/4" Nut Driver to remove Entry Sensor & Sensor Coil KEPS Nuts
- 7) Sense coil gauge (CMI P/N 04700026 .085" thick units, 04700027 for .130" thick units, 04700033 for .102" thick units, 04700042 for .154" thick units),

### **Conversion Interfaces**

<b><u>CMI P/N</u></b>	<b><u>Interface Description</u></b>
0928-000113	8 pin JST connector to flying lead interface
0928-000115	8 pin JST connector to Six pin JST (all model 16)
0928-000116	8 pin JST connector to Six pin Molex (IGT 80960)
0928-000117	8 pin JST connector to Seven pin Molex (all model 62/WMS Optic Emulation)
0928-000126	8 pin JST connector to Six pin JST(all model 40)
0928-000118	8 pin JST connector to 4 pin & 2 pin Molex (Sigma Optic emulation)
0928-000147	12 pin Molex to flying lead Test Header interface
0928-000149	8 pin JST connector to 24-12 VDC converter board (Ballys optic emulation)
0928-000150	8 pin JST connector to 15 pin Molex & 2 pin Molex (IGT Optic emulation)
0928-000151	12 pin Molex to 3 wire flying lead test header interface

# DEFENDER PCB Electrical Specifications

### Selectivity Pot:

Used to adjust the metal match between the Resident coin and the coin to be accepted.

Full Clockwise = 1 o'clock = Poor Metal Match between coins

Mid Range = 9 o'clock = Average Metal Match between coins

Full Counter Clockwise = 5 o'clock = Best Metal Match between coins

### Environmental:

Operating temp.

Storage temp.

Non-Condensing Humidity Range

0 to 60 degree C

-40 to 80 degree C

10%-90%

### INHIBIT:

The basic function of the Inhibit circuit is to detect an external connection to ground. The Inhibit control lead is designed to be connected to a switch, or relay contact, that makes and breaks a connection to ground. An open-collector transistor driver can also be connected to the Defender Inhibit input. Internally the Inhibit circuit is pulled up to the power input voltage by a resistor. Therefore, when the Inhibit control lead is floating a voltage is present on the Inhibit lead. Diodes block positive voltage from entering the circuit, and prevent the Inhibit input from being pulled below ground. An open, unconnected Inhibit control lead is treated as a Logic High. Shorting the Inhibit control lead to Ground is treated as a Logic Low.

### Customer Interface

PIN #	WIRE COLOR	FUNCTION	V Max.	V Min.	I Max.	I Min.
1	BLACK WIRE	GROUND				
2	BLUE WIRE	INHIBIT Control Lead	24 to 4.5 V Logic High	3.0 to 0.0V Logic Low	- 5 mA	
3	WHITE WIRE	READY (Open Collector) Normally Low	30V DC	4V DC	100 mA	1 mA
4	GRAY WIRE	TILT (Open Collector) Normally High	30V DC	4V DC	100 mA	1 mA
5	GREEN WIRE	CREDIT (Open Collector) Normally High	30V DC	4V DC	100 mA	1 mA
6	YELLOW WIRE	SENSE (Open Collector) Normally High	30V DC	4V DC	100 mA	1 mA
7	RED WIRE	+12V POWER IN	15V DC	11V DC	350 mA	50 mA
8	VIOLET WIRE	SENSE (Sourcing) Normally Low	Power In	--	-15 mA	

Mating Connector: JST XHP-8 CMI # 0826-003041

### Test Header

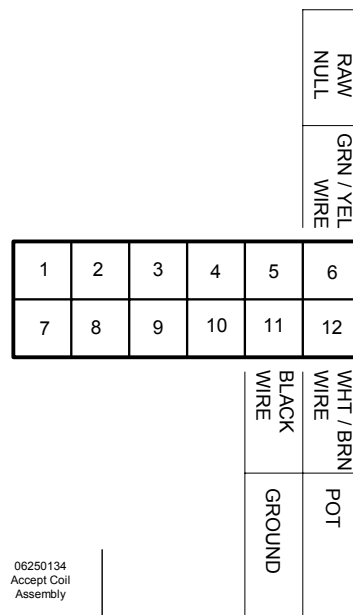

### Connector Configuration

#### TOP VIEW

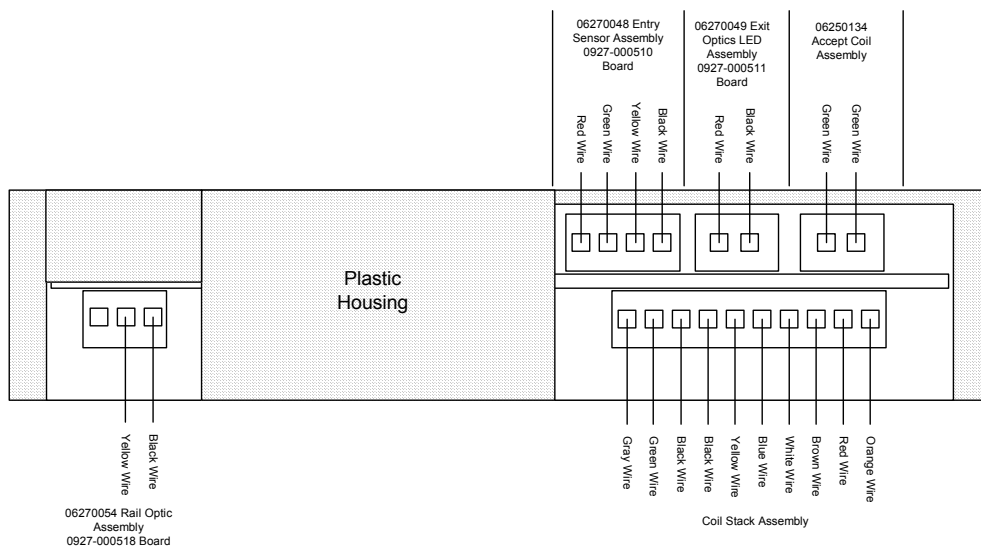

# DEFENDER

## MAGNETIC SENSING COIL AIR BALANCE PROCEDURE USING THE COIN MECHANISMS INC TEST STATION

Air balancing the magnetic sensor coils is an important adjustment and is done to every Mechanism.

When you adjust the coil balance set screws you are adjusting the physical spacing between the magnetic coils. It is important to space the coils an equal distance apart to create equal magnetic fields in the front resident coin gap and in the rear drop slot gap.

1. Choose the correct customer interface for the test station being used, 0928-000113 (8 pin JST connector to flying lead) for older test stations. For new test stations, refer to specific Defender specification sheet for the correct interface. The interface determines the correct inhibit logic and if the Sense signal is open collector or sourcing.
2. Place the Mechanism in a test stand (CMI # 05000009).
3. Connect the interface cable to the test station and mechanism. (For connector pin outs refer to specific spec sheets).

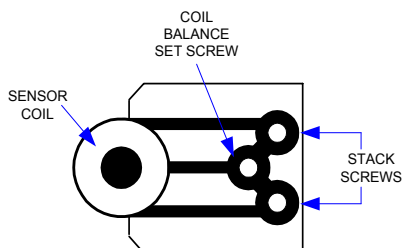

There is a front (resident coin) coil balance set screw, and a back (drop slot) coil balance set screw. Use a 1/16 Inch Allen Wrench Adjustment tool (CMI # 05090004).

4. Remove the Resident Coin, if present.
5. Using the 1/16" allen head hex driver, back out the sensor coil balance adjustment screws counter-clockwise approximately 1/2 turn.
6. Use a 3/32 Inch Torque hex Driver set to 3 1/2 Inch Pounds, and verify the torque on the two screws that hold the coil stack together are torqued down to 3 1/2 Inch Pounds.

### **WITHOUT GAGE BAR**

7. Using the 1/16" Allen Wrench Adjustment tool, slowly tighten the front (resident coin) coil balance set screw just to the point it bottoms out and gets a little hard to turn. Do not over tighten this setscrew. If the coils are being balanced without using a gage bar proceed to step 9.

### **WITH COIL GAP GAGE BAR**

8. a. Insert coil gage bar, with the curve on the bottom right, (refer to table #2) between the first and second coil (resident coin gap). See picture on the next page for correct gage bar orientation.
- b. Using the 1/16" allen head hex driver, turn the *Coil Adjustment Screw* on the front coil clockwise until the gage bar just falls through the coils.

**NOTE: DO NOT OVER ADJUST THIS SCREW AND CREATE AN EXCESSIVE GAP.**

- c. Remove coil balance gage bar.



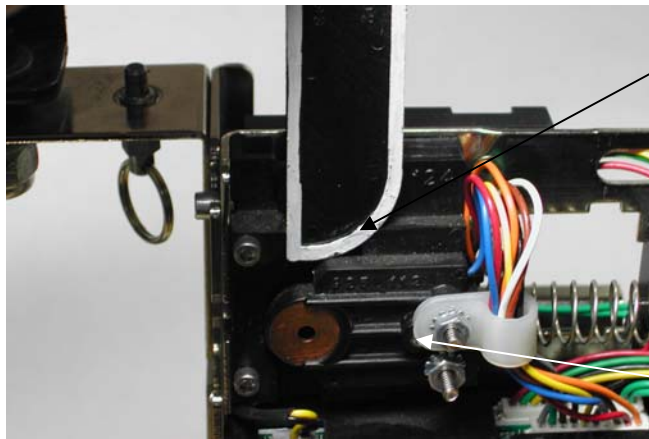

Insert gage bar with the curve towards the coils or on the right side

Insert 1/16" allen head screw driver into Sensor coil adjustment screw

**NOTE:** The gage bar used for coil balancing is determined by the #2 coil part number. See the table and figure below for the location of the #2 coil part number, format and the correct gage bar part number.

#2 Coil Part Number	Gage Bar part number
925 111	04700026
925 123	04700027
925 124	04700033
925 114	04700042

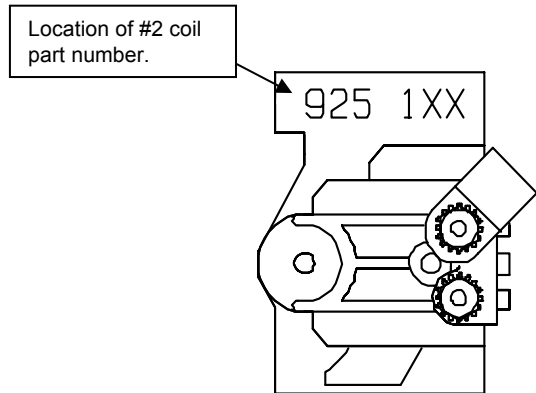

9. Insert a small plastic poker chip (CMI# 04090014) in the resident coin location.
10. Use a 12-Pin Test Header Cable 0928-000151 (12 pin Molex connector to 3 wire flying lead) interface for the older Test Station or the 0928-000132 (12 pin Molex connector to 12 pin Molex connector) interface for the new Test Station.

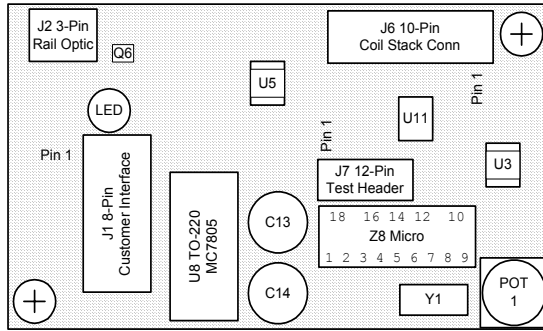

Main PC Board (CMI #0927-000570)

11. If the older Test Station is being used, connect the "MECH TEST POINT" to Pin 6 (GRN/YEL wire) of the test header interface. If the New Test Station is being used, connect the 0928-000132 interface from the Mechanism test header to JP3 "MECH TEST HEADER" of the test station.
12. Apply power to the Mechanism.
13. Monitor the  $\mu\text{A}$  meter on the older Test Station or the DC meter on the new Test Station.
14. Using the 1/16" Allen Wrench Adjustment tool, slowly tighten (clockwise), or adjust the rear (drop slot) coil balance setscrew to achieve the smallest possible Raw Null signal level.

A good null should achieve an air null balance of 0 to 6 $\mu\text{A}$  on the older Test Station.  
Or a DC meter reading of less than 2.00VDC on the New Test Station.

- NOTE: On the older Test Station the Tilt display will continuously run while balancing the coils (if the switches are configured to monitor the TILT signal).  
On the new Test Station, the Tilt display will continuously increment while balancing the coils.

If a good air coil balance cannot be achieved, then there could be a problem with the coil set or the main PC board. In most cases if a good coil air balance cannot be achieved then the coil set needs to be replaced.

15. Insert coil balance gage bar or your thickest coin for this model between the rear (drop slot) coil and middle coil and verify that the gage bar or coin fits. If it does not fit down the drop slot you will be required to readjust the rear coil balance setscrew until the gage bar or coin falls through the Sense coils.
16. If you had to readjust the rear (drop slot) coil balance setscrew again in order for the gage or coin to fit, you will be required to adjust the front (resident slot) coil balance adjustment screw again to produce the lowest possible null.

# DEFENDER

## MAGNETIC SENSING COIL AIR BALANCE PROCEDURE with Oscilloscope

Air balancing the magnetic sensor coils is an important adjustment and is done to every Mechanism.

When you adjust the coil balance set screws you are adjusting the physical spacing between the magnetic coils. It is important to space the coils an equal distance apart to create equal magnetic fields in the front resident coin gap and in the rear drop slot gap.

1. Choose the correct customer interface for the test station being used, 0928-000113 (8 pin JST connector to flying lead) for older test stations. For new test stations, refer to specific Defender specification sheet for the correct interface. The interface determines the correct inhibit logic and if the Sense signal is open collector or sourcing.
2. Place the Mechanism in a test stand (CMI # 05000009).
3. Connect the interface cable to the test station and mechanism. (For connector pin outs refer to specific spec sheets).

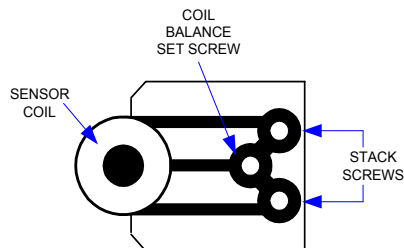

There is a front (resident coin) coil balance set screw, and a back (drop slot) coil balance set screw. Use a 1/16 Inch Allen Wrench Adjustment tool (CMI # 05090004).

4. Remove the Resident Coin, if present.
5. Using the 1/16" allen head hex driver, back out the sensor coil balance adjustment screws counter-clockwise approximately 1/2 turn.
6. Use a 3/32 Inch Torque hex Driver set to 3 1/2 Inch Pounds, and verify the torque on the two screws that hold the coil stack together are torqued down to 3 1/2 Inch Pounds.

### WITHOUT GAGE BAR

7. Using the 1/16" Allen Wrench Adjustment tool, slowly tighten the front (resident coin) coil balance set screw just to the point it bottoms out and gets a little hard to turn. Do not over tighten this setscrew. If the coils are being balanced without using a gage bar proceed to step 9.

### WITH COIL GAP GAGE BAR

8.
  - a. Insert coil gage bar, with the curve on the bottom right, (refer to table #2) between the first and second coil (resident coin gap). See picture on next page for correct gage bar orientation.
  - b. Using the 1/16" allen head hex driver, turn the *Coil Adjustment Screw* on the front coil clockwise until the gage bar just falls through the coils.

**NOTE: DO NOT OVER ADJUST THIS SCREW AND CREATE AN EXCESSIVE GAP.**

- c. Remove coil balance gage bar.

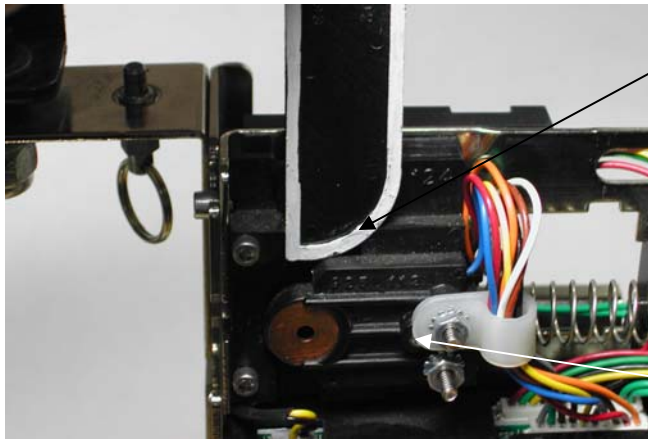

Insert gage bar with the curve towards the coils or on the right side

Insert 1/16" allen head screw driver into Sensor coil adjustment screw

**NOTE:** The gage bar used for coil balancing is determined by the #2 coil part number. See the table and figure below for the location of the #2 coil part number, format and the correct gage bar part number

#2 Coil Part Number	Gage Bar part number
925 111	04700026
925 123	04700027
925 124	04700033
925 114	04700042

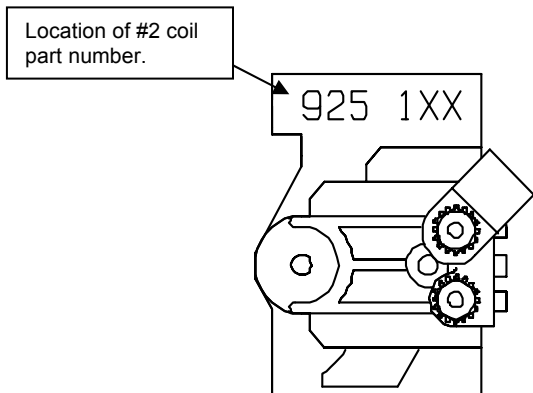

- 9) Insert a small plastic poker chip (CMI# 04090014) in the resident coin location.
- 10) Use a 12-Pin Test Header Cable (CMI #0928-000151). Connect an Oscilloscope to Pin 6 (Raw Null) of the test header or the GRN/YEL wire of the test header interface. Connect the Oscilloscope probe ground to Pin 11 (Ground) of the test header or Black wire of the test header interface.

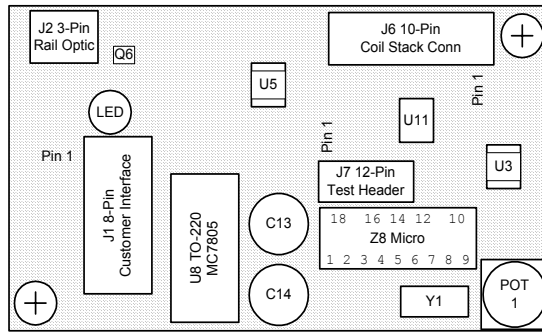

Main PC Board (CMI #0927-000570)

- 11) Set the Oscilloscope to:  
     Horizontal Time Base to 100uS per Division  
     Vertical Display to 100mV per Division
- 12) Apply power to the Mechanism.
- 13) Look at the oscilloscope display. It should be displaying the Raw Null signal, a complex waveform that can oscillate between 7 and 9 KHZ and can have an amplitude of about 9 volts Peak – to – Peak maximum and go down to 50millivolts minimum. You may have to adjust your oscilloscope to properly view the waveform.
- 14) Using the 1/16" Allen Wrench Adjustment tool, slowly tighten, or adjust the rear (drop slot) coil balance setscrew to achieve the smallest possible Raw Null signal level.

A good mechanism should achieve an air coil balance Raw Null signal level  
of less than 700 mV Peak-to-Peak,  
or less than 400 mV Positive Peak to Ground.

If a good air coil balance cannot be achieved, then there could be a problem with the coil set or the main PC board. In most cases if a good coil air balance cannot be achieved then the coil set needs to be replaced.

- 15) Insert coil balance gage bar or your thickest coin for this model between the rear (drop slot) coil and middle coil and verify that the gage bar or coin fits. If it does not fit down the drop slot you will be required to readjust the rear coil balance setscrew until the gage bar or coin falls through the Sense coils.
- 16) If you had to readjust the rear (drop slot) coil balance setscrew again in order for the gage or coin to fit, you will be required to adjust the front (resident slot) coil balance adjustment screw again to produce the lowest possible null.

# DEFENDER RAIL ADJUSTMENT PROCEDURE

## DROP SLOT DIAMETER CLEARANCE

1. Insert proper resident coin for the model to be adjusted.
2. Turn the side rail set screw out (Counterclockwise) one full turn.
3. Drop a good coin into the drop slot, it should get stuck. If the coin does not get stuck, push the coil set (with the resident coin installed) toward the rail (left) (this should force the rail insert in). Drop another good coin into the drop slot, the coin should get stuck. If the coin still does not get stuck, contact COIN MECHANISMS INC.

**NOTE:** The unit may Tilt during the Drop Slot Diameter clearance adjustment procedure.

4. Turn the side rail set screw (using a .050" hex driver or CMI P/N 05090023) in (Clockwise) until the coin falls through the mechanism.  
Drop more good coins and slightly adjust the side rail set screw until all the test coins fall freely through the mechanism.
5. Turn the side rail set screw an additional ¼ turn in (Clockwise) for some additional diameter clearance.

Side View of Unit

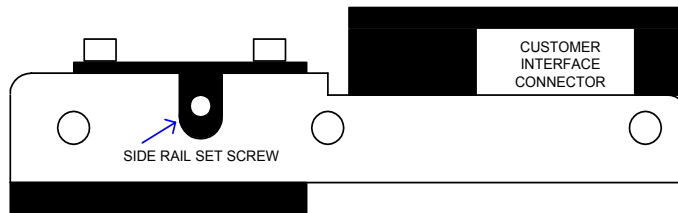

**WARNING:** The diameter adjustment side rail set screw must never be turned more than ¼ turn clockwise from this calibrated setting to prevent damage to this assembly

6. Drop good coins through the unit.  
The unit should Accept 100% of the good coins.  
Each coin should generate a Sense and Credit Pulse (if applicable) as the coin falls through the mechanism  
  
The POT setting may need to be adjusted to achieve 100% acceptance if the test coins have a wide conductivity spread.

# DEFENDER

## Cleaning and Preventive Maintenance

The Defender Comparitor is made from nickel-plated steel and high strength nylon molded plastic parts. This high security mechanism requires tighter tolerances within the mechanical assemblies of the product and its control of the coins being processed through it. Keeping the mechanism clean is important for long term, trouble free operation. Debris such as cigarette or cigar smoke (tar and nicotine), ashes, coin dust, liquor, soft drinks, and cleaning fluids easily adhere themselves to critical areas within the coin mechanism. This debris can affect the sliding sensor coil, the operation of the accept gate, and the speed of the coin through the device. Any of these can have an adverse affect on proper coin validation. Use the following guidelines to keep the mechanism clean and trouble free.

- When cleaning the outside face of a machine, prevent liquid and spray cleaning solution from entering the mechanism via the coin slot by blocking or covering the coin slot when cleaning. If the coin slot is not blocked, the cleaning fluid will combine with all other debris that enters through the coin slot and congeal into a sticky film that will inhibit coin acceptance.
- Clean any spilled drinks from the mechanism as soon as possible to prevent buildup of debris. A mild solution of dishwashing detergent will remove drinks. The circuit boards must not be exposed to the dishwasher solution. They must be removed and be cleaned if necessary with circuit board flux remover or a combination of isopropyl alcohol and freon.
- Cigarette and cigar smoke can be removed with a general-purpose lens cleaner used for eyeglasses. This cleaner can also be used on mechanisms with a build-up of film from spray cleaning.
- After any cleaning it is important to wipe any excess solution from the mechanism then buff or blow-dry with clean compressed air.
- The sensor coil assembly should be removed from the metal mainplate and carefully cleaned around the periphery of the two parts where they slide against each other.
- Never use any oils, wax, or petroleum based solvents or sprays to clean the Comparitor.
- The environment determines frequency of cleaning. Once every 3 months is a safe cleaning schedule. If the environment is heavily smoked filled with a large volume of coin play, then a more frequent schedule may be necessary.