

19 (GB)

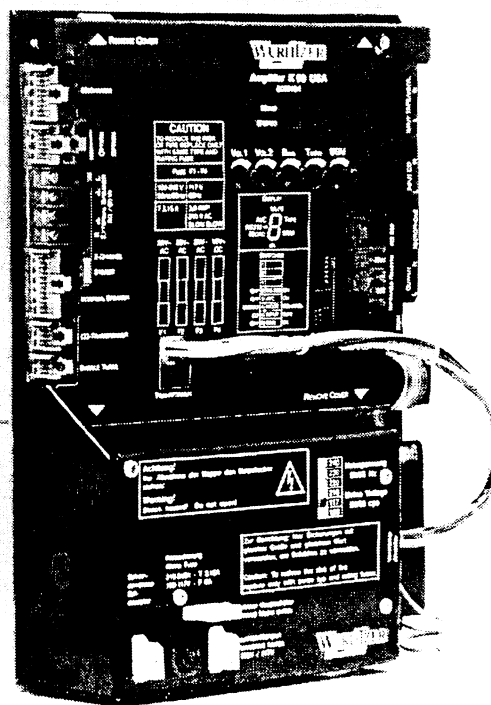

CE

Amplifier K99



OPERATING INSTRUCTIONS

Table of contents

1	Device description of the amplifier K99	2
2	Technical data	2
3	Verification of power voltage	3
4	Position of fuses and plug connectors on the K99	4
5	The first power ON	5
6	Volume control	5
7	Treble and bass control	7
8	Automatic volume correction	7
9	Background Music - volume attenuation	7
10	External speaker connection	8
11	External amplifier connection	9
12	Disabling the internal mute circuit	9
13	Input selector	9
14	Wiring diagrams	10

Subject to alterations

1 Device description of the amplifier K99

The amplifier K99 (K= Kompakt, 99 = year of development) is optimised for universal use in DW music machines. Great importance had been attached for an easy handling and stand alone function without the S&CC unit. The output power is designed for the typical used internal speakers at Wurlitzer machines, under normal circumstances reaching an impeccable volume level.

DETAILS:

Standard equipment:

- Hybrid power stage technology, short circuit and over temperature protected
- 2 inputs (stereo): CD and tape
- 1 mono input for optional micro kit
- Volume control with 2 pots onboard
- Volume control possible with pots and / or IR at the same time. The pot used at last determines the volume.
- Bass and treble control with pots
- BGM volume reduction, controllable with pot
- Automatic volume correction (AVC), switchable
- 2 channel operation switchable, RH = internal speakers, LH = external speakers
- Status display with 7segment display
- Independent controllable RCA output to connect external amplifiers
- For use with the old and the new changer mechanism.

Optional:

- Remote control of F91 with large distance range. Functions: track selection / volume chan. 1 / volume chan. 2 / mute (toggle) / cancel
- Volume control with two pots in the wired remote box accessible from the machine rear wall, or external. Cancel button and mute button (with toggle function)
- Output transformer (like F91)
- Microphone kit

2 Technical data

Supply:	100V - 240V
Mains frequency:	50Hz - 60Hz
input voltage CD:	typ. 1,2 V
input voltage tape:	300 mV
Output voltage pre amplifier:	<= 1Veff
Output power:	2 x 55W (rms)
Output impedance:	min. 4 Ohms
Transmission range :	20Hz(cps) - 20000Hz(cps)
Distortion factor:	< 1%

Noise level:

Depending on the adjusted volume of the jukebox loudness levels of more than 70 dB(A) can be reached.

3 Verification of power voltage

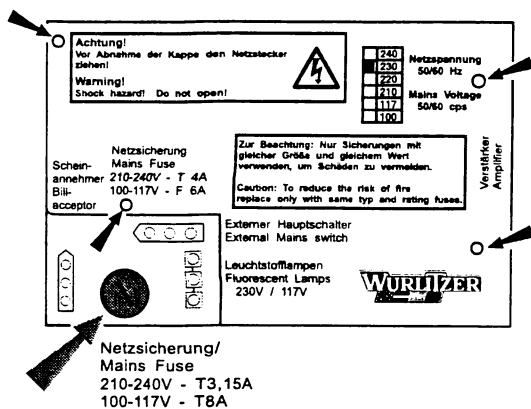

The voltage settings are marked on the cover plate of the mains transformer. Machines for USA are set to 117 V. Jukeboxes "UNI-Pack" are shipped in 230 V setting. This is marked on the machine label inside of the door. If the voltage setting is not clear the transformer cover plate has to be removed. The mains fuse (T3,15A) is located on the left bottom side in-between the three terminals for the bill acceptor, the external mains switch and the fluorescent lamps.

Loosen the four screws to remove the cover plate (small arrows).

Always remove power plug before opening transformer cover plate. Never attempt any intervention to these parts unless qualified!

The position of the two plug connectors on the transformer terminals 1 to 9 (primary side) indicates the current voltage setting. The following combinations are possible:

- 240V = 1 - 9
- 230V = 1 - 8
- 220V = 2 - 9
- 210V = 2 - 8
- 117V = 1 - 6
- 100V = 2 - 6

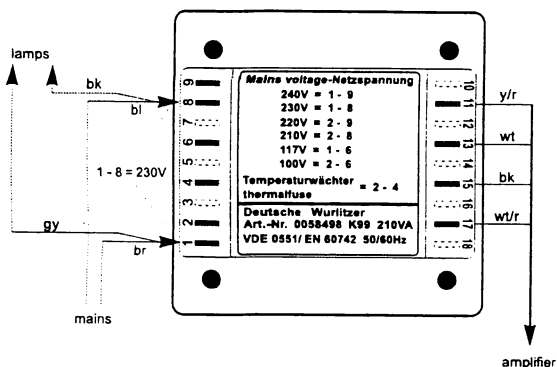

Never connect the fluorescent supply to other contact.

If you intend to change the power voltage for a higher voltage (e.g. from 117V to 230V) it is better to use a subtransformer for the fluorescent lamps or change the ballast according to the used voltage (e.g. for 230V).

4 Position of fuses and plug connectors on the K99

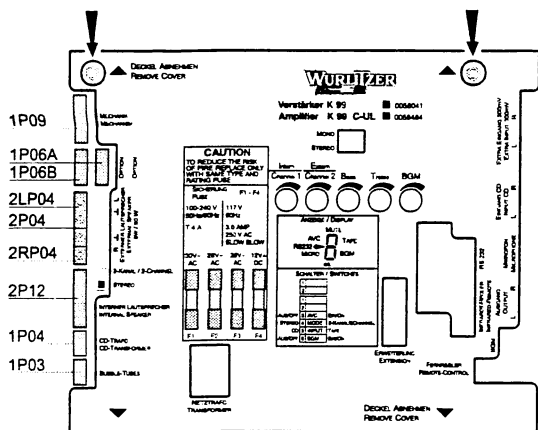

Usually the jukeboxes are fitted with fuses of DIN 41 571 (5x20 mm) slow blow or medium blow. Slow blow fuses of DIN standard bear the letter T (T = "Träge") e.g. T 4/250 means T = slow blow, 4 amps, 250 V maximum operating voltage. Which fuses have to fit in where is printed on the power transformer cover. Fast blow fuses (F = Flink) are unsuitable for the jukebox. The fuse holder on the amplifier P.C.B. are capable to hold also fuses of 6x32 mm size.

You will find the fuses behind the amplifier cover plate. To remove the plate unplug first the cable coming from the mains transformer. Next lose slightly both nuts on top of the amplifier accessible through the holes in the cover plate (arrows). To remove the plate first take the bottom side out of its hinges and then the top side.

Connection plan of the plug terminals:

- 1P09 - mechanism, SCC unit
- 1P06A - option
- 1P06B - option
- 2LP04 - external speakers, LH
- 2P04 - external speakers, ground
- 2RP04 - external speakers, RH
- 2P12 - internal speakers
- 1P04 - CD sub transformer, CD player
- 1P03 - bubble tubes

Fuse	Failure
<p>Main fuse T 3,15,res. T8 A for 110/117 V.</p> <p>Fuse F1: T4A supply 30V ~</p> <p>Fuse F2: T4A supply 26V ~</p> <p>Fuse F3: T4A supply 26V ~</p> <p>Fuse F4: T4A supply +12 V=</p>	<p>No illumination, machine completely dead.</p> <p>The digital digit on the CD-control is dark. Power supply for CD player and control unit is interrupted. Credit circuit via LED M is interrupted. If credits are still in memory or free play is programmed; a CD will be placed on turntable but is not spinning.</p> <p>The colour tubes of the One More Time do not rotate, the heating of the bubble tubes is off - no bubbles will appear. Possibly defect of the power stage of the amplifier.</p> <p>SCC unit dead - digital display dark (except red LED M still lighting up on coin insertion). The LED's K and Z on the SCC unit are dark. No initialisations run after power ON. The status display on the amplifier is dark.</p>

5 The first power ON

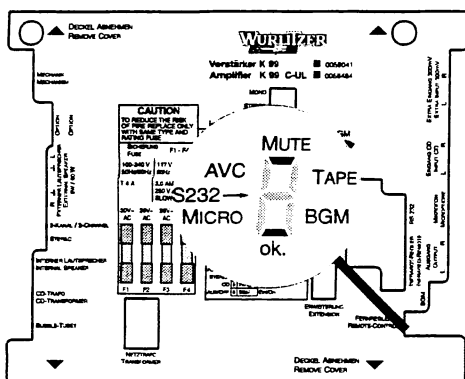

The mains switch is located at the rear side of the amplifier and thus it is on the rear side of the jukebox. For wallboxes it is possible to connect an external mains switch to the amplifier accessible than from the side. In position 'I' jukebox and amplifier are switched on.

Up to approx. 1 sec. after power on random segments of the status display will light. Followed displaying the version number of the amplifier software (1.0, or higher). Then the bottom segment for "ok." and the upper segment for MUTE will light. The amplifier is now in STANDBY MODE. Depending on other enabled options more segments may light as well (e.g. AVC).

6 Volume control

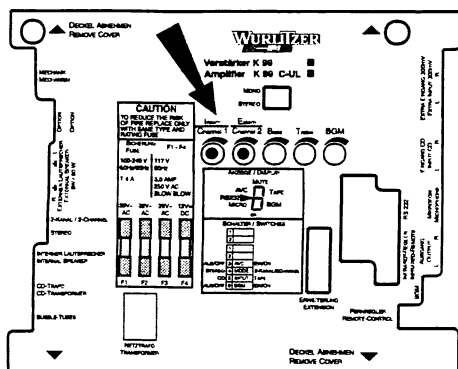

You can control the volume of the jukebox from different points at the same time:

1. With the pots Vol.1 and Vol.2 on the amplifier.
2. With an optional connectable IR remote control.
3. With the pots of the control box at the rear side of the jukebox.

The device from which the volume is changed determines it.

The volume control unit can be taken out and may be mounted at another place as a remote control. Its cable may be extended as required with any kind of wire. The voltages of the control wires are 5V DC.

The control box has two volume knobs (Intern / Channel 1 and Extern / Channel 2). In position "Stereo" the knob "Intern / Channel 1" is effective for the internal speakers. The knob Extern / Channel 2 is controlling the volume of the RCA outputs for an optional external amplifier. In position "2 Channel" of the DIPswitch the channels 1 (RH) and 2 (LH) are controllable separately.



The pots Vol.1 and Vol.2 on the amplifier are not effective if the wire control box is connected.

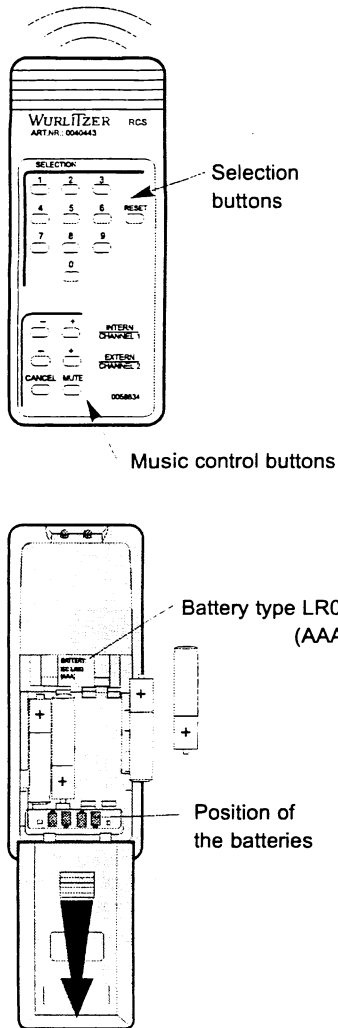

The infrared remote control

As desired an infrared remote control will be installed **from** factory or can be delivered as conversion kit (part no. 40435). If it has been installed the hand transmitter is located in the cashbox.

If credit is given or free play is programmed a CD can be selected with the buttons 0 to 9 and R.

Double button functions as required in the service programs (i.e. press button 5 -hold down- and press button R), are impossible. For this you only can use the keyboard of the jukebox.

You can control the volume by means of the buttons + and -. In stereo mode the internal +/- buttons control the volume of the internal speakers. The external +/- buttons control the volume of the K99 RCA jacks for an optional external amplifier. In 2-channel mode you can control the external speakers by the buttons + and - of the external channel.

Beam the jukebox directly if possible.

You can connect the wire remote control box as well.

The power-on volume level is always set by the channel 1 and 2 pots on the amplifier or on the control box (if connected).

Batteries will not be delivered. Necessary are 4 micro cells type LR03 (AAA).

To open the battery compartment move the cover like shown in the picture.

Needed battery type and position of the batteries in the hand transmitter are shown on the casing.

Part no. of the hand transmitter: 0040443.

7 Treble and bass control

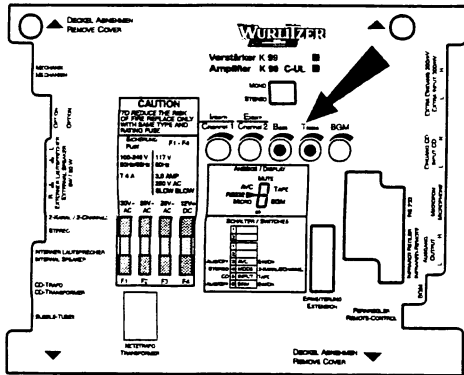

You can control the sound with the knobs bass and treble on the amplifier.

8 Automatic volume correction

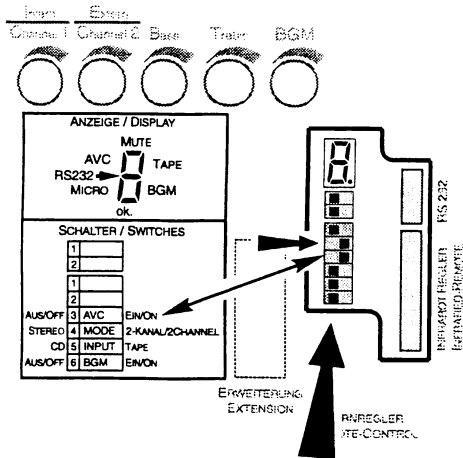

The AVC sets CDs with different volume levels to an equal level. The level of CDs with a high level will be reduced; the level of low-levelled CDs will be increased. This control works rather slow to save the dynamic range of the track. You can enable the correction with the DIP switch "AVC" the 3rd switch of the 6 sw. group. Default is AVC disabled. With the second DIP of the 6 sw. group you can reduce the intensity of volume correction.

9 Background Music - volume attenuation

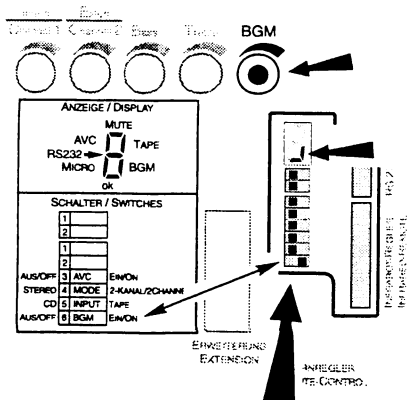

In the BGM (Back Ground Music) mode the reproduction loudness will be reduced by a certain factor. The signal "BGM" pin 1 plug brown of the SCC unit controls this function. You also can switch "BGM" on by means of the DIP switch "BGM" for test purposes. The RH bottom segment of the status display on the amplifier indicates "BGM active". You can adjust the volume attenuation with the pot "BGM", as long it is active.

10 External speaker connection

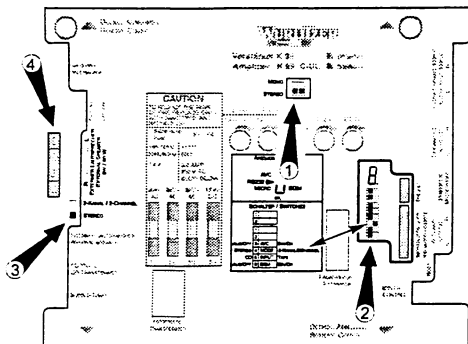

Position of the Stereo - Mono DIP switch (1), the mode switch in the 6 sw. group (2), the stereo - 2 channel switch (3) and the external speaker terminals (4).

The amplifier can operate in two different modes. The normal operation mode reproduces the music in normal stereo sound. So external speakers can be added to each channel. The so-called 2Channel mode uses both stereo channels like separate mono amplifiers so that the sound can be reproduced in different rooms but then in mono only.

The amplifier may not be loaded with more than 4 ohms per channel (less ohms means more load!). On an overload it switches itself off. After a certain cool down time it switches itself on. So if you do not eliminate the reason for the overload the amplifier produces continuously volume dropouts.

The impedance of all external speakers per channel in "Stereo" mode should not be less than 8 ohms, because the cabinet speakers represent a load of already 8 ohms per channel. If the amplifier is operating in 2-Channel mode, the internal speakers are all loaded to the RH channel (Channel 1); the LH channel (Channel 2) now applying to the screw terminals "Externe Lautsprecher - External speakers" may be loaded with max. 4 ohms.

The amplifier applies approx. 55 watts (rms on max. 1% dist.) on a 4 ohms speaker per channel, 18 watts to a 12 ohms speaker and approx. 9 watts to a 24 ohms speaker. That means, that e.g., a 12 ohms speaker connected to the external channel at Dual Channel operation must be a type of at least 18 Watts, otherwise the speaker is in danger of destruction at higher volumes. Note that speaker groups like in hi-fi boxes may have, at certain frequencies, impedance's much lower than their rating. Make sure that all speakers are connected in correct polarity.

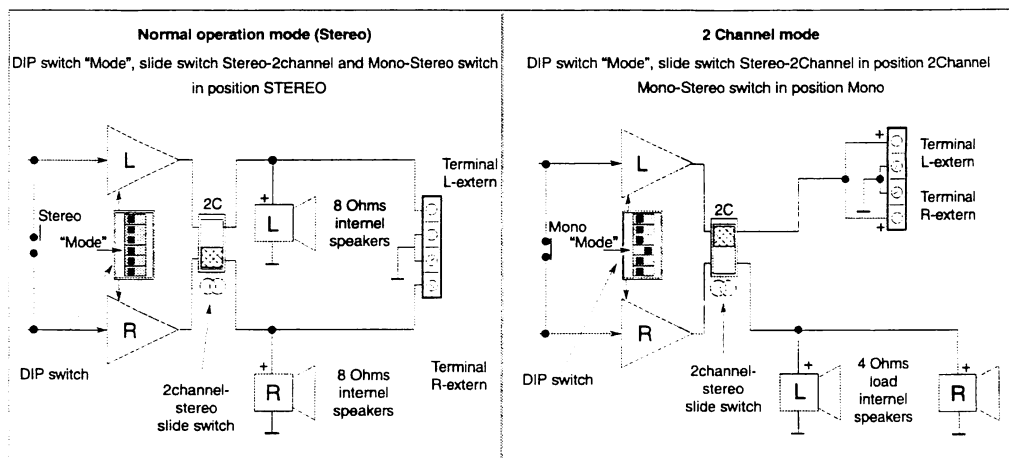

Connect external speakers to the screw terminals on the LH amplifier side.

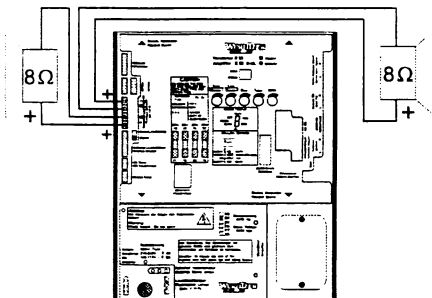

In Stereo mode do not connect a single speaker with less than 8 ohms to each channel.

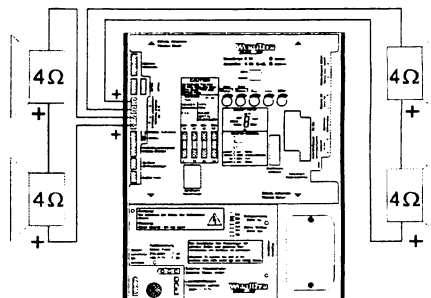

Two speakers of 4ohms also represent total impedance of 8 ohms.

11 External amplifier connection

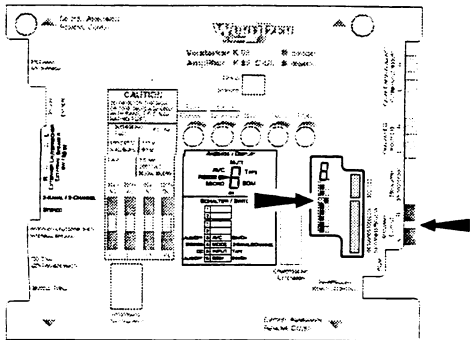

On the RCA terminals "Ausgang - Output" you can connect an external amplifier with any power rate. In Stereo mode the output level is normally controlled by means of the pot for the 2nd channel. Alternatively you can set the first DIP switch of the 6 sw. group to ON to couple this output to the normal volume control knobs (1st channel), so that both amplifiers can be controlled together.

Connecting an external amplifier in 2-channel mode is not useful.

To avoid hum- (earth-) loops try to use an external amplifier with ground insulation; it has no earth contacts. If it is impossible (e.g. receivers with cable supply) you can separate both amps by means of the ground isolator part no. 0053300.

The signal of the RCS terminals is also controlled by the settings of bass, treble, BGM, AVC and Mute.

12 Disabling the internal mute circuit

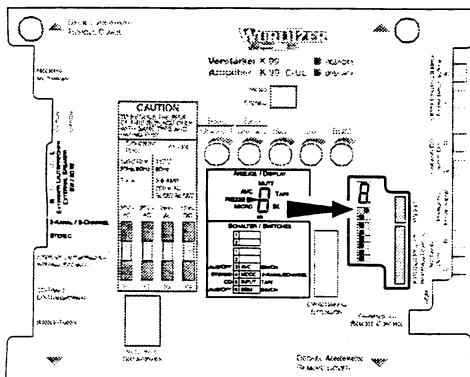

With the optional BGM-Connector (part no. 0048133) you can connect an external source to the jukebox. In this case the amplifier should not be muted during standby of the jukebox.

To reach this disable the internal mute circuit by setting the first DIP switch of the 2 sw. group "Mute" to OFF.

For more information order the Wurlitzer technical information leaflets TI-MA-116 (for F91).

13 Input selector

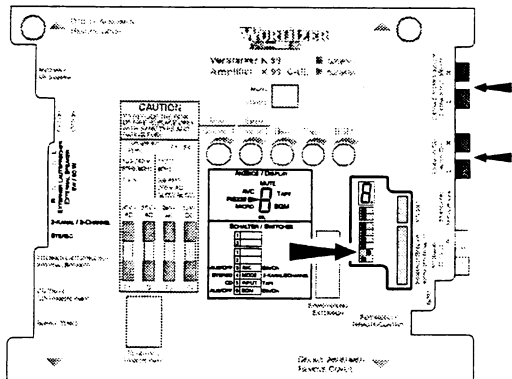

With the 5th DIP switch of the 6 sw. group you can set either CD or tape input as active.

Bubble Tubes



Transformer

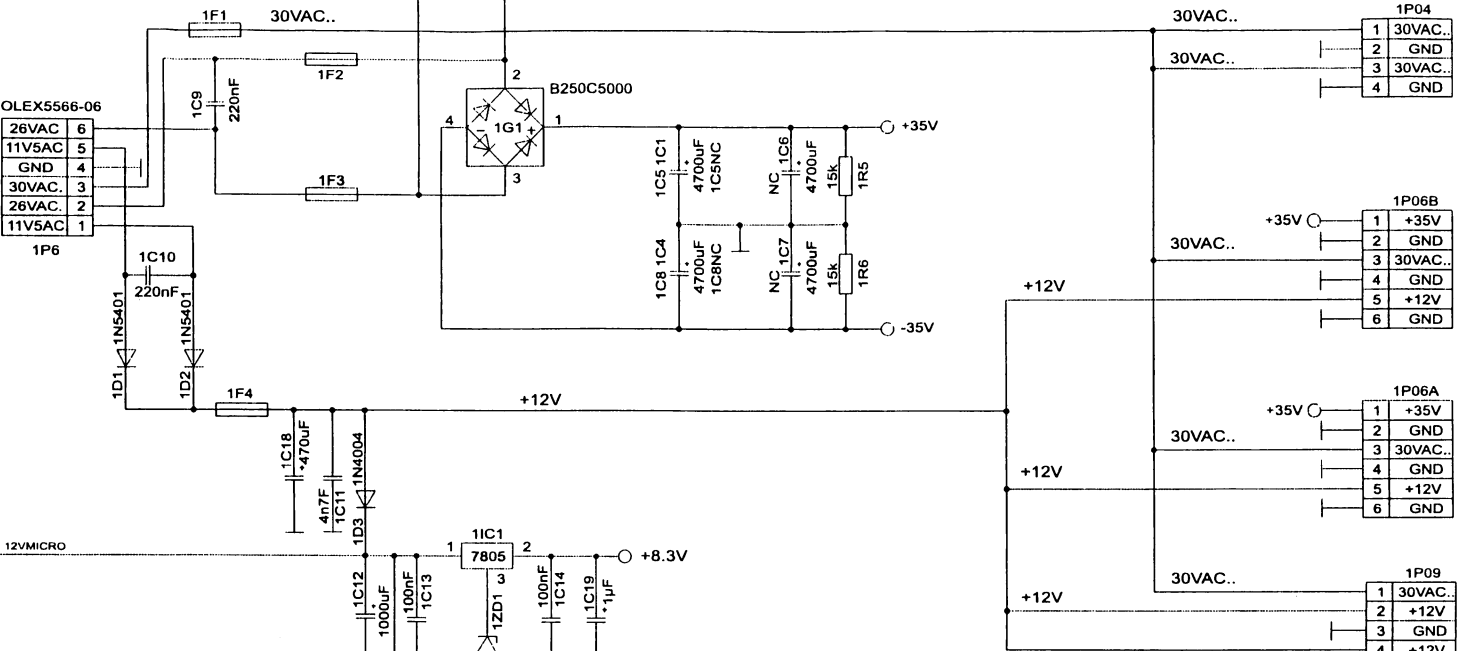
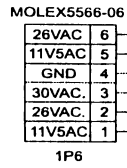

CD Trafo



Option



Option



Mechanik

5(6) ← 12V MICRO

SICHERUNG - FUSE 1-4	
100V-240V 50Hz/60Hz	117V/60Hz
T4A	3.0 AMP 250V AC SLOW BLOW

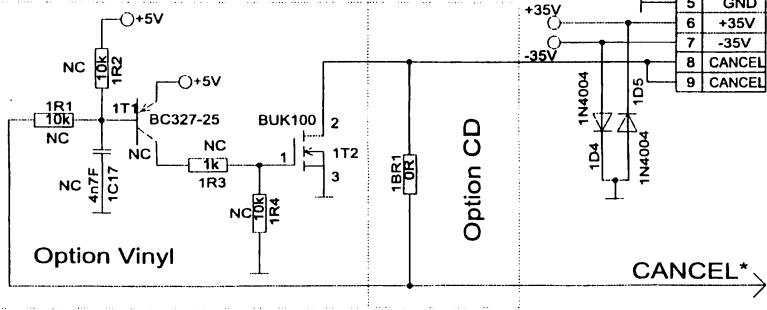

CANCEL* → 4,5(6)

Schaltplan
Verstärker K99 (1) - Spannungsversorgung
Wiring diagram
Amplifier K99 (1) - Power supply

01.2000

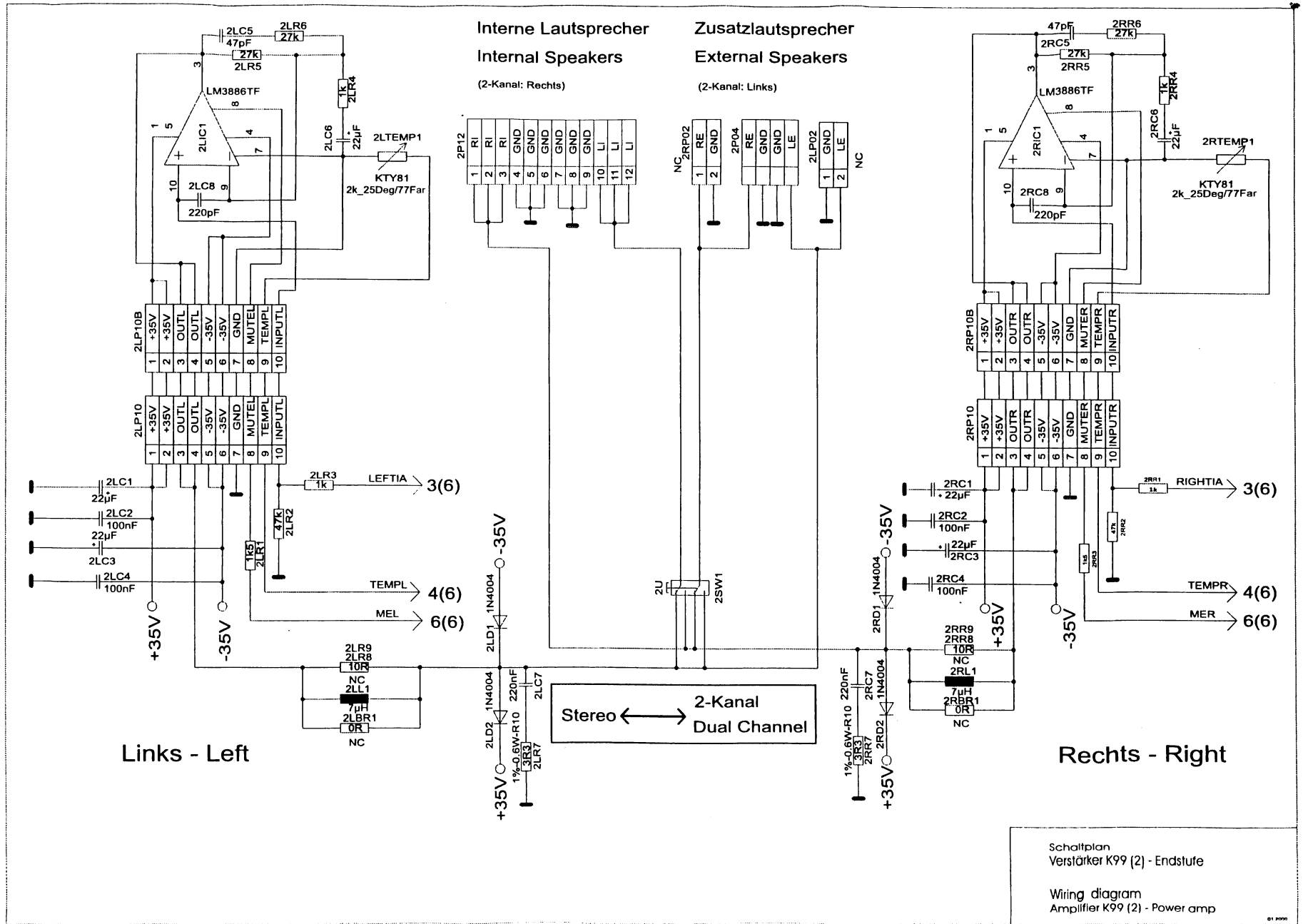

Schaltplan
Verstärker K99 (2) - Endstufe
Wiring diagram
Amplifier K99 (2) - Power amp

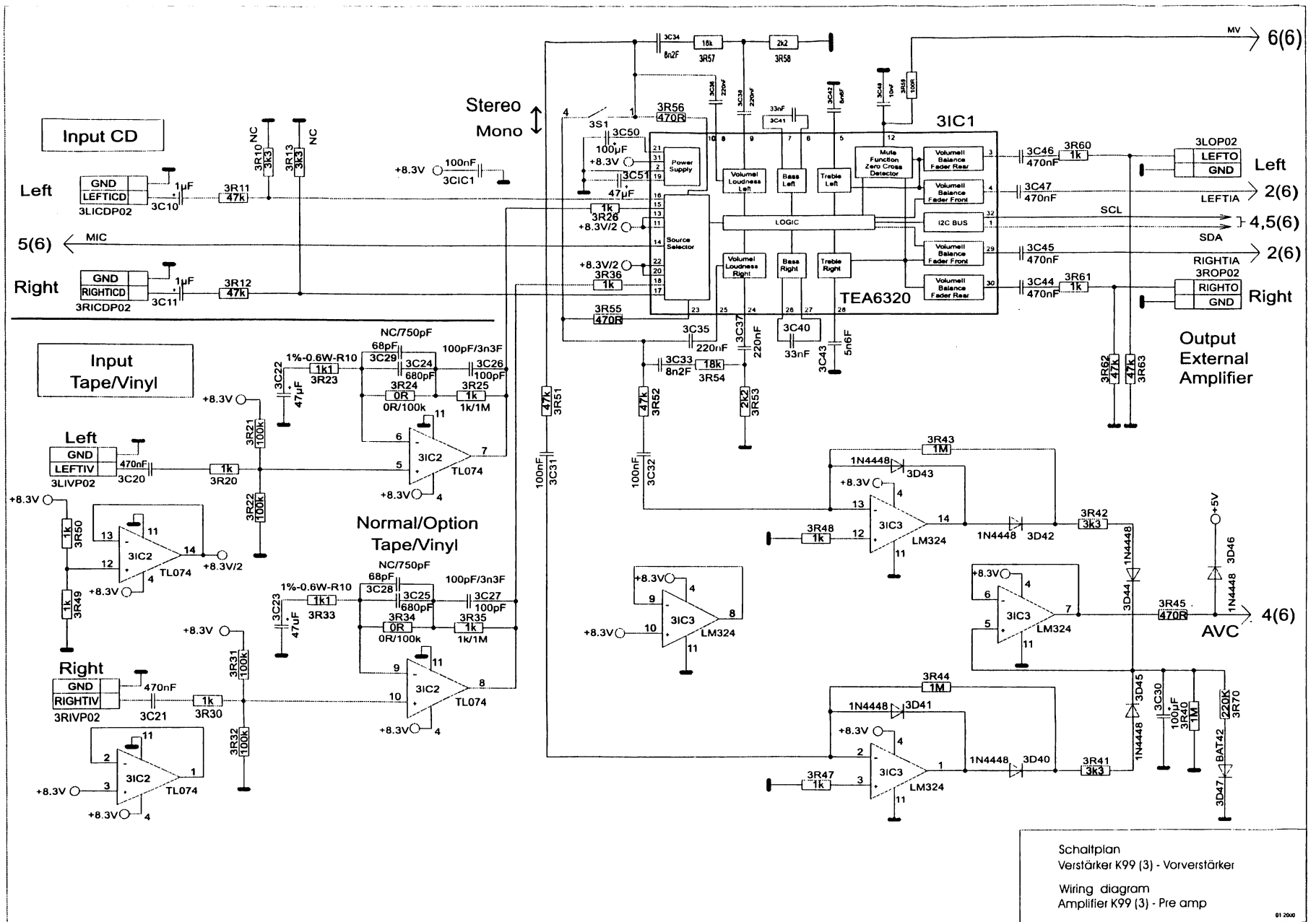

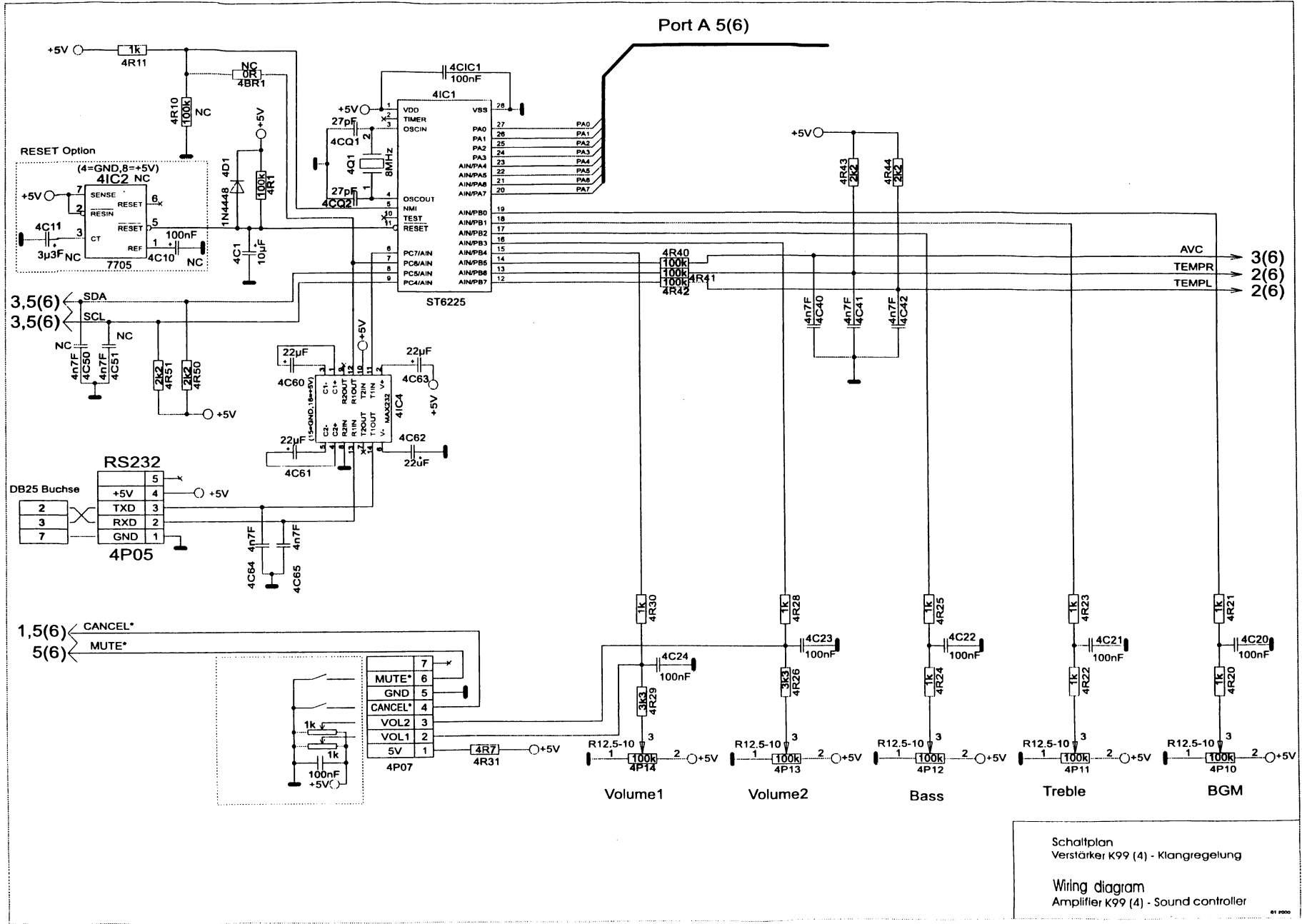

Schaltplan
Verstärker K99 (4) - Klangregelung

Wiring diagram
Amplifier K99 (4) - Sound controller

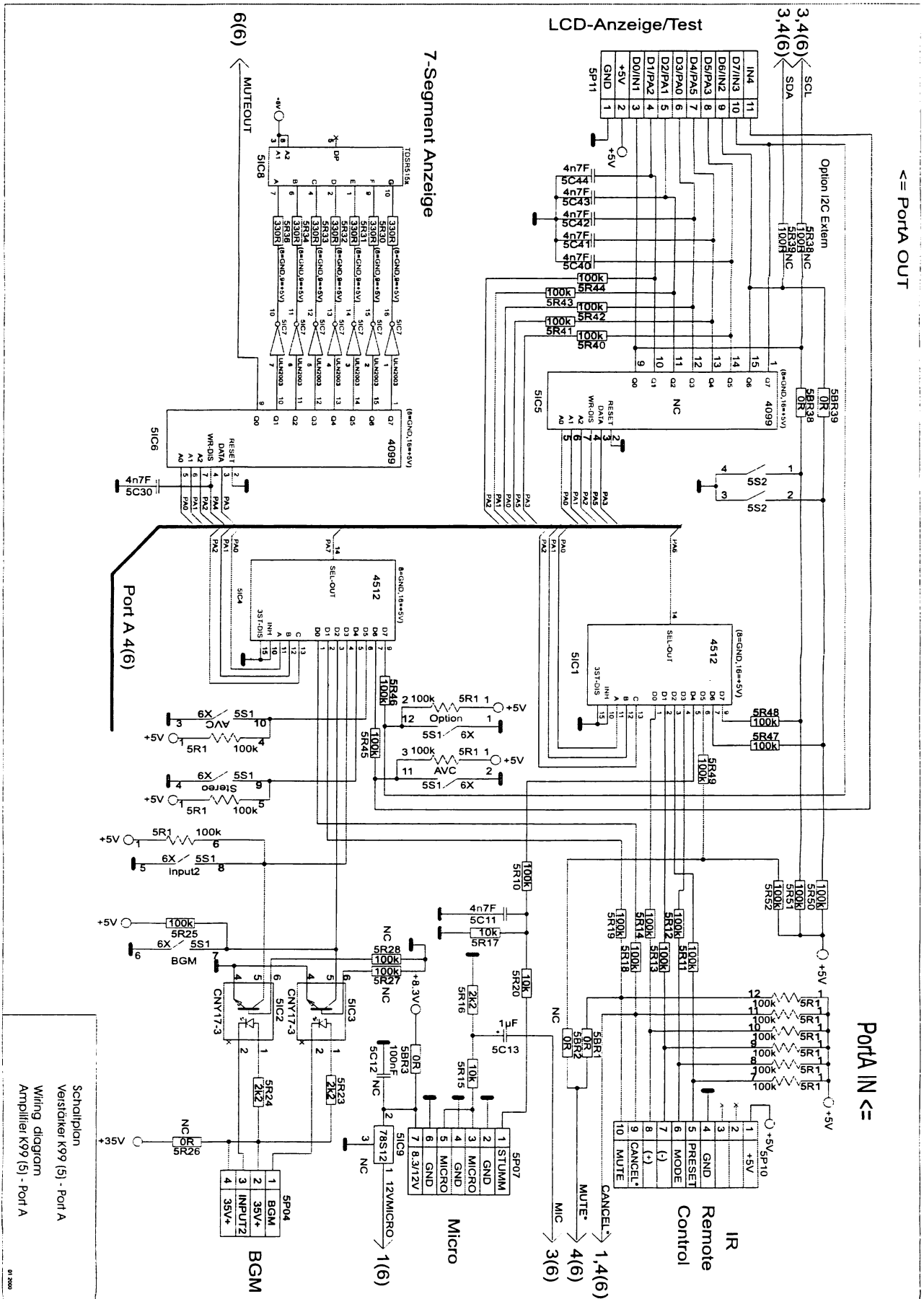

Schaltplan
Verstärker K99 (5) - Port A
Wiring diagram
Amplifier K99 (5) - Port A

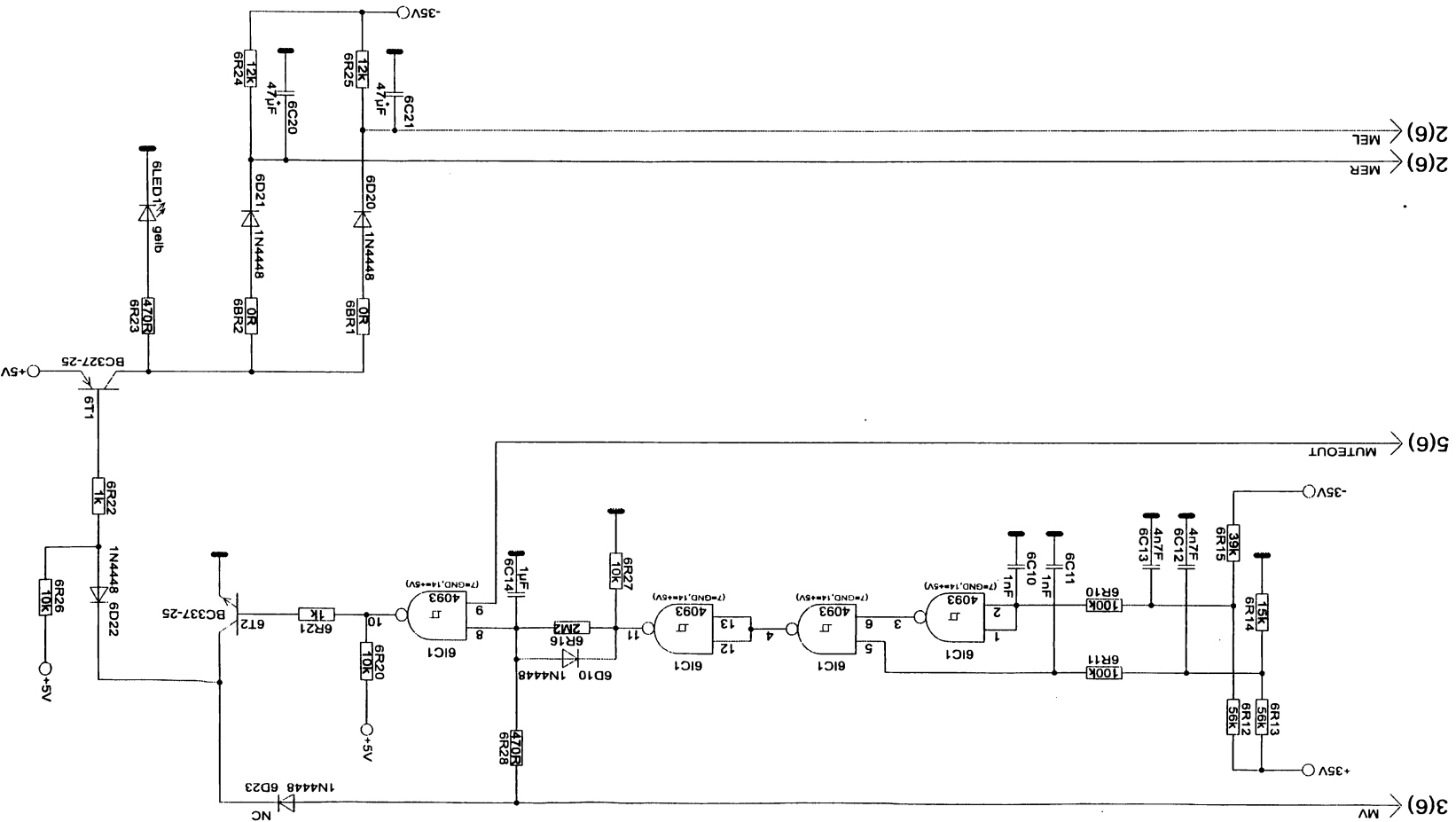

Schaltplan
Verstärker K99 (6) - Mute (Stummschaltung)

Wiring diagram
Amplifier K99 (5) - Mute

01 2000 10

Netzanschluss 230V

Power Supply 230V

Options

- 1-9 : 240V
- 1-8 : 230V
- 2-9 : 220V
- 2-8 : 210V
- 1-6 : 117V
- 2-6 : 100V

Netzspannung
Mains Voltage

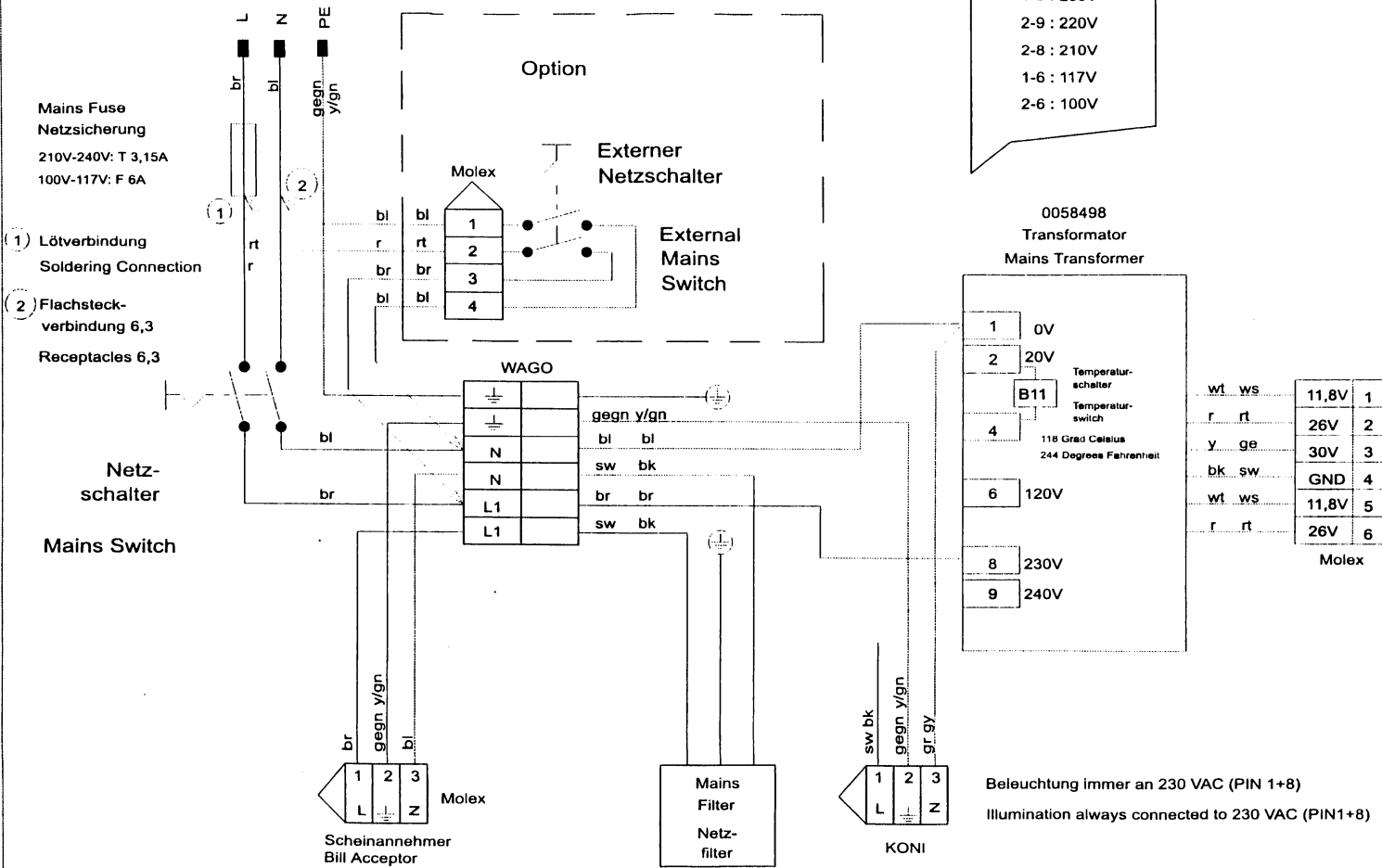

Mains Fuse
Netzversicherung
210V-240V: T 3,15A
100V-117V: F 6A

(1) Lötverbindung
Soldering Connection

(2) Flachsteck-
verbindung 6,3
Receptacles 6,3

Netz-
schalter

Mains Switch

WAGO

gegn v/gn

bl bl

N N

sw bk

br br

sw bk

Molex

Scheinannehmer
Bill Acceptor

Mains Filter
Netz-
filter

KONI

Beleuchtung immer an 230 VAC (PIN 1+8)

Illumination always connected to 230 VAC (PIN1+8)

0058498
Transformator
Mains Transformer

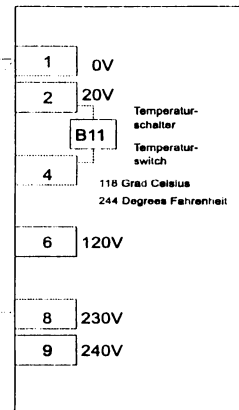

wt	ws	11,8V	1
r	rt	26V	2
y	ge	30V	3
bk	sw	GND	4
wt	ws	11,8V	5
r	rt	26V	6

Molex

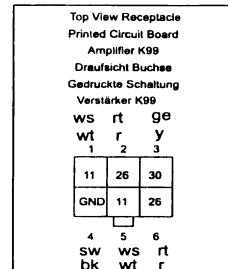

Schaltplan
Verstärker K99 - Netzanschluss, Euro 230V
Circuit diagram
Amplifier K99 - Power supply, Euro 230V

Power Supply 117V
Netzanschluss 117V

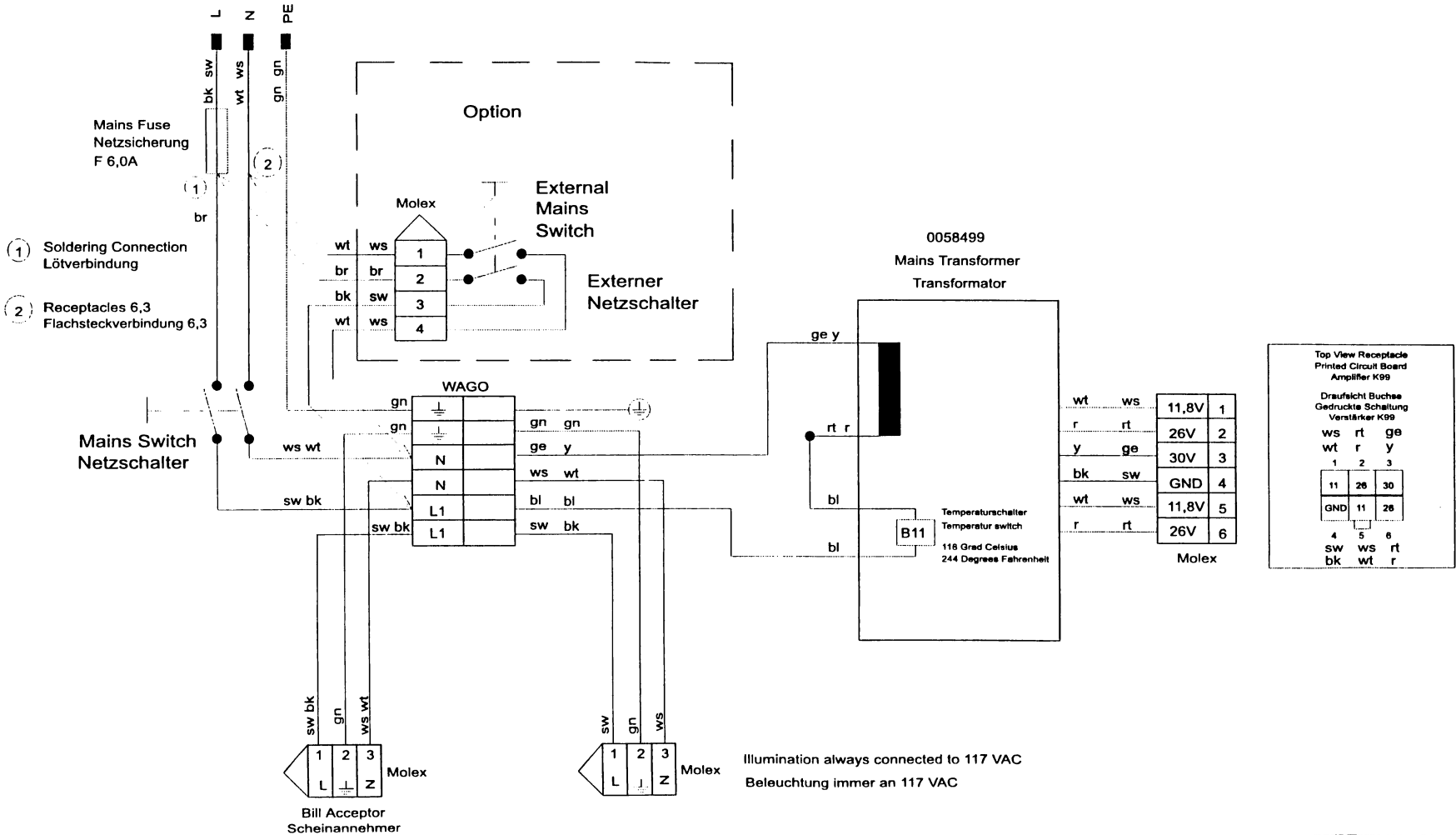

Illumination always connected to 117 VAC
Beleuchtung immer an 117 VAC

Circuit diagram
Amplifier K99 - Power supply, UL/USA 117V

Schaltplan
Verstärker K99 - Netzanschluss, UL/USA 117V