



14 MAR 1983

January 31, 1983

Table 1-6 Switch Settings for Qualifying Lap Times

## TECHNICAL UPDATE

### POLE POSITION™

- o The inability of high score retention after a player has entered his initials can easily be resolved. Change the 3.3v zener diode CR6 (1N4728) to a 3.9v  $\frac{1}{2}$ w zener diode (1N748A), or 3.9v  $\frac{1}{2}$ w (1N5228). The Atari part number is 131000-002.
- o Maximum speed limitations are caused by improper program initialization on either power up or activating self test. Refer to page 1-10 of the service manual which contains important information relating to this subject. Always double check that the gas pedal is in the uppermost position prior to power up or self test.
- o Double objects, split objects or video tearing may be related to a 74LS161\* in the Horizontal Address Counters on the video PCB (Locations 9H, 9K, 10H, 10J, 10K and 10L). To determine the failing IC, heat each IC with a soldering iron for about 30 seconds. A failing IC will cause the video to change. The most likely suspects are 9H and 10H. Replace with a 74S161\*\*
- o Continuous high gear operation can be insured by proper setting of the gear shift switch. Loosen the two switch holding screws, push and hold the switch as close as it will go towards the actuator pin and then tighten the screws.

\* Atari PN - 37-74LS161

\*\* Atari PN - 137287-001

Continued On Back



## TECHNICAL UPDATE

- o An intermittent or grounded 5v on the CPU PCB could be a mechanical contact between the foil of capacitor C54 and a trace. Simply rotate the cover of the capacitor until the short is removed. The capacitor is located between IC's 10D and 10E.
  
- o Fuse F-3 used in the Power Supply Tray is a 25 Amp fuse. If the F-3 label indicates a 20 Amp, change label to show 25 Amp fuse. Also, make the appropriate change to the schematic (SP-218) on page 3B.
  
- o Make the following changes to the Service Manual TM-218:
  - Page 1-6, Figure 1-4: The On/Off positions of the PCB option switches are reversed. Actually up should be Off and down should be On.
  
  - Page 3-11, Steering Wheel parts list: The Radial Optical Coupler part number should read 139002-001. The 030369-01 is not and should not be used.
  
  - Page 1-9, Switch Settings: Staple the accompanying Pole Position Qualifying Time to this page. The table lists all the qualifying time for each starting pole position and difficulty levels. You may want to make an extra copy to staple inside the game for easy reference.
  
- o Page 3-14, Figure 3-7: Circled potentiometer harness connections should be changed. The red and black connections should be swapped.

Table 1-5 Switch Settings for Qualifying Lap Times

9L Option Switches			Self-Test Practice Rank	Level of Difficulty	Beat This Many Seconds to Qualify for Position:							
1	2	3			1	2	3	4	5	6	7	8
On	Off	On	F	Easy ↓ Hard	66	68	70	73	75	77	80	82
Off	Off	On	E		65½	67½	70	72½	74½	76½	79	81
On	On	On	H		59½	61	63	66	68	70	72	75
On	On	Off	D		59	61	63	65	67	69	71	74
Off	On	Off	C ←		58½	60	62	64	66	68	70	73
On	Off	Off	B		58	60	62	64	66	68	70	72
Off	Off	Off	A		57½	59	61	63	65	67	69	71
Off	On	On	G		57	59	61	63	65	67	69	71

←Manufacturer's recommended settings

"REWINDING THE PULLEY CABLE"

1. PLACE FOOT-PEDAL CONTROL ASSEMBLY UPSIDE DOWN ON WORK SURFACE WITH PEDAL IN FULLY-OPEN POSITION AND HINGED END AWAY FROM YOU.
2. ROTATE PULLEY UNTIL CAP SCREW POINTS STRAIGHT UP.
3. HOOK THE LARGER-DIAMETER EYELET OF THE CABLE TO THE FOOT-PEDAL BRACKET.
4. THREAD THE CABLE UP THROUGH THE BASE-PLATE OPENING.
5. WRAP THE CABLE 1/4 - TURN AROUND THE PULLEY AND BRING OUT THROUGH THE NOTCH TOWARD THE CAP SCREW.
6. WRAP THE CABLE TWICE AROUND THE CAP SCREW IN A CLOCKWISE DIRECTION.

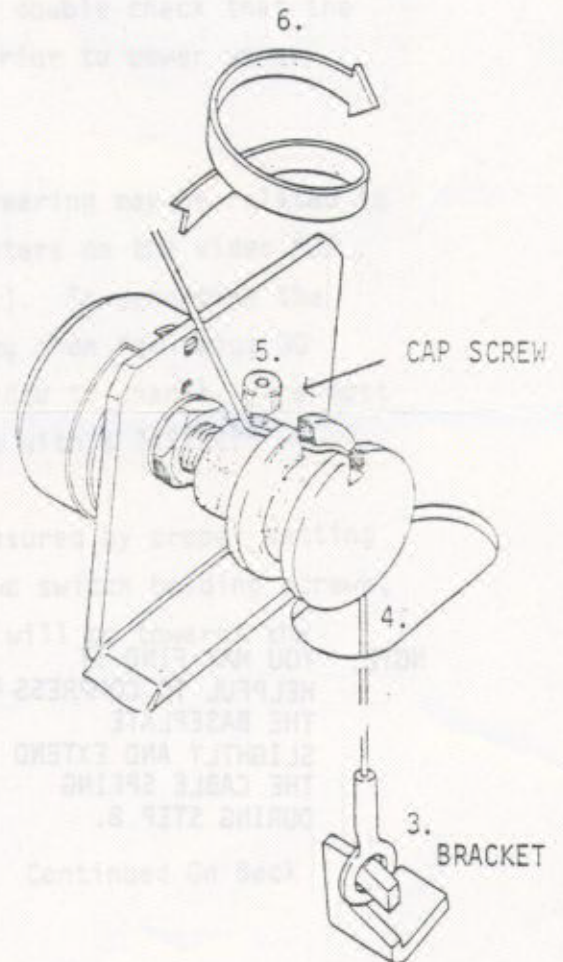

## "REWINDING THE PULLEY CABLE"

Part No.	Part Name	Qty.	Notes
1	Baseplate	1	
2	Bracket	1	
3	Cap Screw	1	
4	Washer	1	
5	Lock Washer	1	
6	Pin	1	
7	Pin	1	
8	Pin	1	
9	Pin	1	
10	Pin	1	
11	Pin	1	
12	Pin	1	
13	Pin	1	
14	Pin	1	
15	Pin	1	
16	Pin	1	
17	Pin	1	
18	Pin	1	
19	Pin	1	
20	Pin	1	
21	Pin	1	
22	Pin	1	
23	Pin	1	
24	Pin	1	
25	Pin	1	
26	Pin	1	
27	Pin	1	
28	Pin	1	
29	Pin	1	
30	Pin	1	
31	Pin	1	
32	Pin	1	
33	Pin	1	
34	Pin	1	
35	Pin	1	
36	Pin	1	
37	Pin	1	
38	Pin	1	
39	Pin	1	
40	Pin	1	
41	Pin	1	
42	Pin	1	
43	Pin	1	
44	Pin	1	
45	Pin	1	
46	Pin	1	
47	Pin	1	
48	Pin	1	
49	Pin	1	
50	Pin	1	

- BRING THE CABLE BACK THROUGH THE NOTCH AND WRAP ONE AND ONE-HALF TURNS AROUND THE PULLEY.

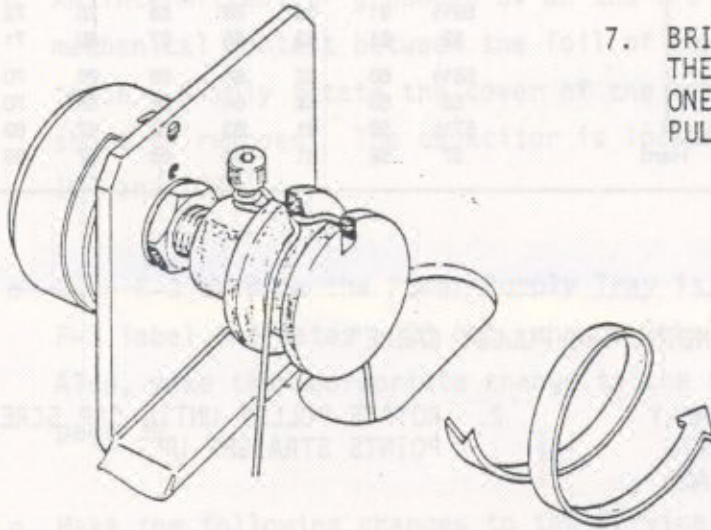

- ATTACH THE SMALLER EYELET ON THE CABLE TO THE CABLE SPRING.

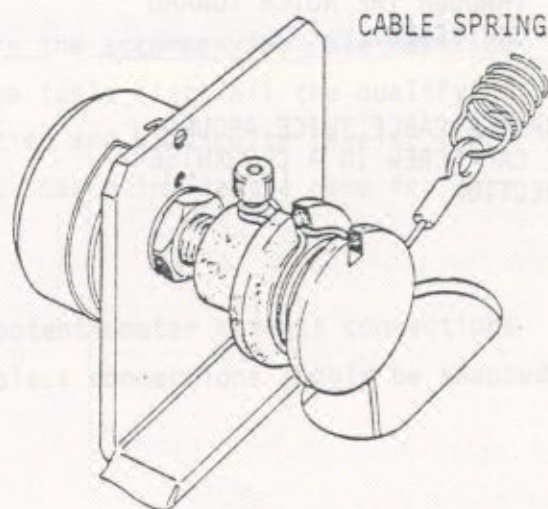

NOTE: YOU MAY FIND IT HELPFUL TO COMPRESS THE BASEPLATE SLIGHTLY AND EXTEND THE CABLE SPRING DURING STEP 8.

DEC 17 1982

17 JAN 1983

FIELD SERVICE

Coin Operated Games Division



NEW GAME

TECHNICAL UPDATE

POLE POSITION

- o The inability of high score retention after a player has entered his initials can easily be resolved. Change the 3.3v zener diode CR6 (1N4728) to a 3.9v  $\frac{1}{4}$ W zener diode (1N748A), or 3.9v  $\frac{1}{2}$ W (1N5228). The Atari part number is 131000-002.
  
- o Maximum speed limitations is caused by improper program initialization on either power up or activating self test. Refer to page 1-10 of the service manual which contains important information relating to this subject. Always double check that the gas pedal is in the uppermost position prior to power up or self test.
  
- o Double objects, split objects or video tearing may be related to a 74LS161 in the Horizontal Address Counters on the video PCB (Locations 9H, 9K, 10H, 10J, 10K and 10L). To determine the failing IC, heat each IC with a soldering iron for about 30 seconds. A failing IC will cause the video to change. The most likely suspects are 9H and 10H. Replace with a 74S161.
  
- o Continuous high gear operation can be insured by proper seating of the gear shift switch. Loosen the two switch holding screws, push and hold the switch as close as it will go towards the actuator pin and then tighten the screws.

Continued on Back



FIELD SERVICE  
JAN 17 1985

DEC 17 1985

Continued on back

- o An intermittent or grounded 5v on the CPU PCB could be a mechanical contact between the foil of capacitor C54 and a trace. Simply rotate the cover of the capacitor until the short is removed. The capacitor is located between IC's 10D and 10E.

The intensity of high score retention after a player has entered his initials can easily be resolved. Change the 0.3V zener diode CR8 (1M475) to a 1.5V zener diode (1M475A), or 0.3V zener diode (1M475B). The Atari part number is 131000-002.

Maximum speed limitations is caused by improper program initialization on either power up or activating soft test. Refer to page 1-10 of the service manual which contains important information relating to this subject. Always double check that the gas pedal is in the upmost position prior to power up or soft test.

Double objects, split objects or video tearing may be related to a 74LS161 in the Horizontal Address Counter on the video PCB (locations 9H, 9K, 10H, 10J, 10K and 10L). To determine the failing IC, heat each IC with a soldering iron for about 30 seconds. A failing IC will cause the video to change. The most likely suspects are 9H and 10H. Replace with a 74LS161.

Continuous high gear operation can be insured by proper seating of the gear shift switch. Loosen the two switch holding screws, push and hold the switch as close as it will go towards the actuator pin and then tighten the screws.

Continued on back