

# Votrax<sup>®</sup>

1394 Rankin  
Troy, MI. 48083

## SC-01 SPEECH SYNTHESIZER DATA SHEET

### Votrax<sup>®</sup> CMOS Phoneme Speech Synthesizer

#### GENERAL DESCRIPTION

The SC-01 Speech Synthesizer is a completely self-contained solid state device. This single chip phonetically synthesizes continuous speech, of unlimited vocabulary, from low data rate inputs. Figure 1.

Speech is synthesized by combining phonemes (the building blocks of speech) in the appropriate sequence. The SC-01 Speech Synthesizer contains 64 different phonemes which are accessed by a 6-bit code. It is the proper sequential combination of these phoneme codes that creates continuous speech.

The SC-01 Speech Synthesizer is cost-effective, consumes minimal power and enables in-house product development without vendor dependency. Signals from the SC-01 are applied to an audio output device to amplify and distribute the synthesized speech. See Figure 2.

#### FEATURES

- Single CMOS chip
- 70 bits per second
- 22 pin package
- 9 ma. current drain
- Wide voltage supply range
- Latched 5V. compatible inputs
- Digital pitch level inputs
- Automatic inflection
- On-chip master clock circuit
- Optional external master clock
- Variety of voice effects
- Sound effects
- Customer product security

The design of the equipment specified herein is proprietary. Rights for the reproduction and distribution of the data contained herein are granted except for the manufacture and reproduction of the subject equipment.

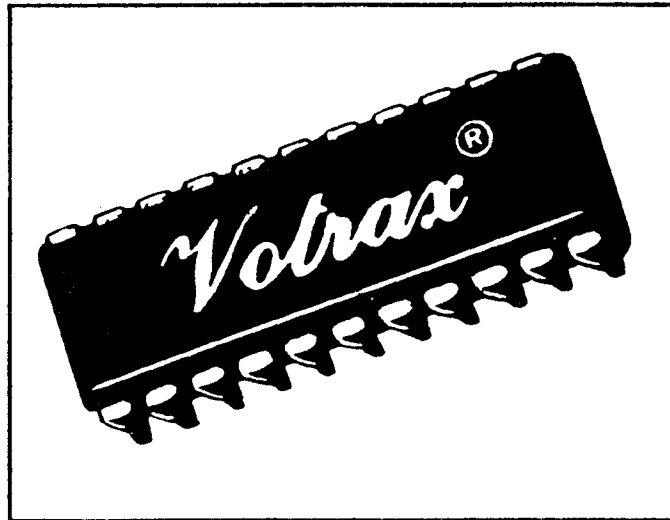

Figure 1. Votrax<sup>®</sup> SC-01 Speech Synthesizer

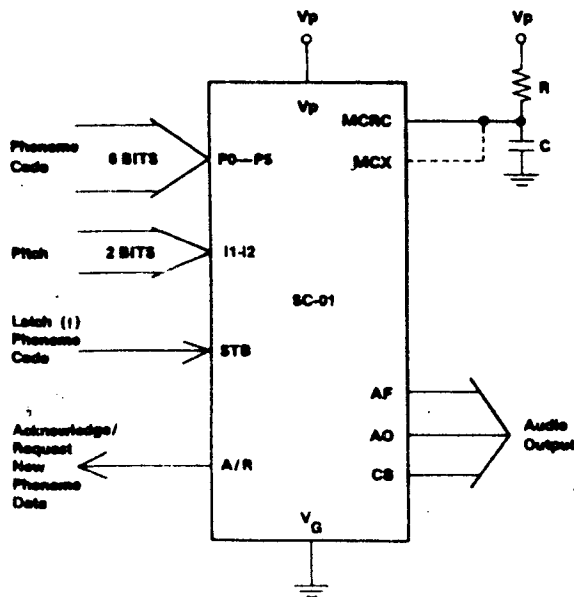

Figure 2. SC-01 Flow Diagram

CMOS technology, which offers high input impedance and low power drain.

## ELECTRICAL DESCRIPTION

The SC-01 Speech Synthesizer is a program-compatible with existing Votrax<sup>®</sup> phoneme synthesizers. It requires 70 bits of data per second for continuous speech production. The 6-bit phoneme codes are 5 volt logic compatible and are latched for data bus applications. A phoneme-construction algorithm and filters, within the chip, create the synthesized audio output.

example word demonstrate the phoneme use, i.e., sound to be pronounced.

Table 2 subdivides the 64 phoneme symbols into seven categories. Each category represents a different production feature. The first six categories are characterized by voiced, fricative (expired voice), and nasal sounds. The seventh category is characterized by phonemes with no sound output.

## PHONEME PROGRAMMING

**Manual Operations:** Votrax<sup>®</sup> maintains a library of phonetically programmed words. Reference to this library and programming manuals will aid in word synthesis.

**Automatic Operations:** Votrax<sup>®</sup> can supply a micro-computer system for automatic conversion of English text into phoneme sequences. This system is particularly useful for in-house vocabulary development and product security. Contact Votrax<sup>®</sup> for further information.

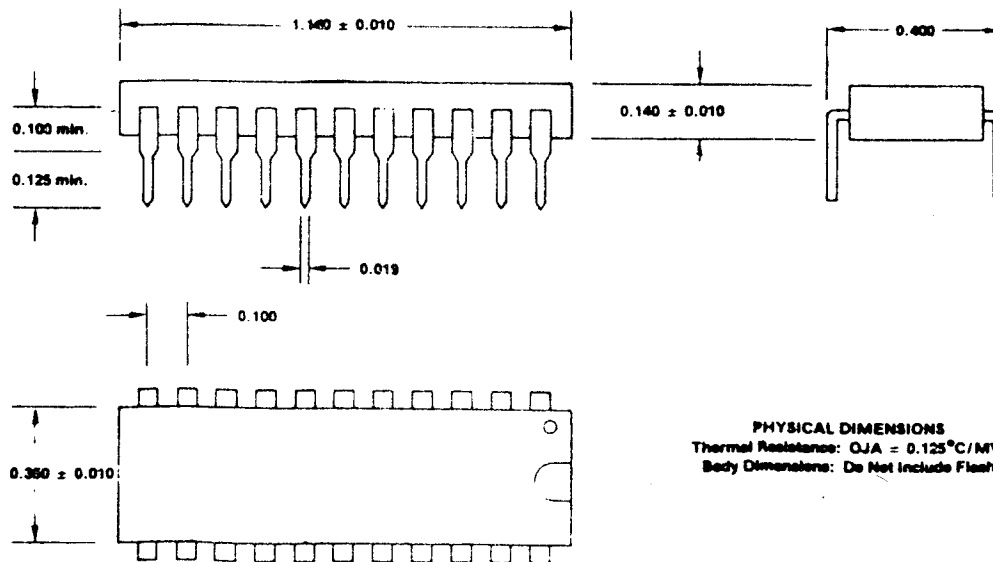
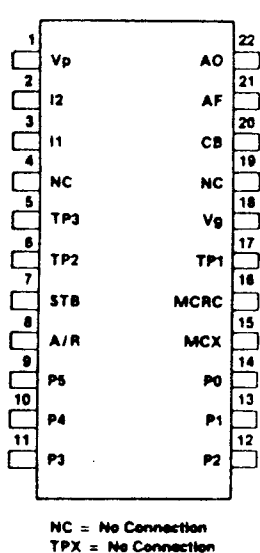

Table 1. Phoneme Chart

1-8 HEX  
 9-16 PHON  
 17-24 CAT  
 25-32 DUR  
 33- EXAMPLE

Phoneme Code	Phoneme Symbol	CAT	Duration (ms)	Example Word
00	EH3	✓	59	jacket
01	EH2	✓	71	enlist
02	EH1	✓	121	heavy
03	PA0	NS	47	no sound
04	DT	FS	47	butter
05	A2	✓	71	made
06	A1	✓	103	made
07	ZH	VF	90	azure
08	AH2	✓	71	honest
09	I3	✓	55	inhibit
0A	I2	✓	80	inhibit
0B	I1	✓	121	inhibit
0C	M	N	103	mat
0D	N	N	80	sun
0E	B	VS	71	bag
0F	V	VF	71	van
10	CH*	F	71	chip
11	SH	F	121	shop
12	Z	VF	71	zoo
13	AW1	✓	146	lawful
14	NG	N	121	thing
15	AH1	✓	146	father
16	OO1	✓	103	looking
17	OO	✓	185	book
18	L	✓	103	land
19	K	FS	80	trick
1A	J*	VF	47	judge
1B	H	F	71	hello
1C	G	VS	71	get
1D	F	F	103	fast
1E	D	VS	55	paid
1F	S	F	90	pass

Phoneme Code	Phoneme Symbol	Duration (ms)	Example Word
20	A	✓	185 day
21	AY	✓	65 day
22	Y1	✓	80 yard
23	UH3	✓	47 mission
24	AH	✓	250 mop
25	P	FS	103 past
26	O	✓	185 cold
27	I	✓	185 pin
28	U	✓	185 move
29	Y	✓	103 any
2A	T	FS	71 tap
2B	R	✓	90 red
2C	E	✓	185 meet
2D	W	✓	80 win
2E	AE	✓	185 dad
2F	AE1	✓	103 after
30	AW2	✓	90 salty
31	UH2	✓	71 about
32	UH1	✓	103 uncle
33	UH	✓	185 cup
34	O2	✓	80 for
35	O1	✓	121 aboard
36	IU	✓	59 you
37	U1	✓	90 you
38	THV	VF	80 the
39	TH	F	71 thin
3A	ER	✓	146 bird
3B	EH	✓	185 get
3C	E1	✓	121 be
3D	AW	✓	250 call
3E	PA1	NS	185 no sound
3F	STOP	NS	47 no sound

\*T/ must precede /CH/ to produce CH sound.

\*D/ must precede /J/ to produce J sound.

Table 2. Phoneme Categories According to Production Features

Voiced	V	VF 'Voiced' Fricat.	VS 'Voiced' Stop	FS Fricative Stop	F Fricative	N Nasal	NS No Sound			
E	EH	AE	UH	OO1	Z	B	T	S	M	PA0
E1	EH1	AE1	UH1	R	ZH	D	DT	SH	N	PA1
Y	EH2	AH	UH2	ER	J	G	K	CH	NG	STOP
Y1	EH3	AH1	UH3	L	V		P	TH		
I	A	AH2	O	IU	THV			F		
I1	A1	AW	O1	U				H		
I2	A2	AW1	O2	U1						
I3	AY	AW2	OO	W						

**SIGNAL DESCRIPTION** (See Figures 4 and 5)

**NOTE**

**Phoneme 6-Bit Selection Code (P0-P5):** Data input is to six pins. Latching is controlled by the strobe (STB) signal.

Varying clock frequency varies voice and sound effects. As clock frequency decreases, audio frequency decreases and phoneme timing lengthens. Figures 6 and 7 illustrate manual and DAC (Digital to Analog Converter) voice variation schematics, respectively.

**Strobe (STB):** Latching occurs on rising edge of strobe signal.

**Inflection Level Setting (I1, I2):** Instantaneously sets pitch level of voiced phonemes.

**Acknowledge/Request ( $\bar{A}/R$ ):** Acknowledges receipt of phoneme data (signal goes from high to low one master clock cycle following active edge of STB signal). Also indicates timing out of old phoneme concurrent with request for new phoneme data (signal goes from low to high)

**Master Clock External (MCX):** Allows control by an external clock signal.

**NOTE**

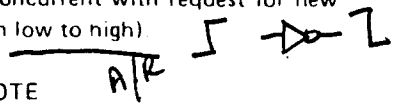
NOTE  Ground MCRC during MCX operation.

If external phoneme timing is desired, phoneme requests can be ignored. However, best speech is realized with internal timing.

**Audio Output (AO):** Supplies analog signal to audio output device.

**Audio Feedback (AF):** Used with Class A or Class B transistor audio amplifiers for added stability

**Master Clock Resistor-Capacitor (MCRC):** This input determines the internal master clock frequency. Select R-C values for 720 kHz to achieve standard phoneme timing. Connect this input to MCX when using internal clock; ground when using external clock.

**Class B (CB):** Current source for Class B transistor audio amplifier

Table 3. Timing Specifications

CHARACTERISTIC	SYMBOL	MIN	TYP	MAX	UNIT
Input Setup Time ( $P_i$ to STB)	$T_S$	450			NS
Input Hold Time ( $P_i$ to STB)	$T_H$	0			NS
Rise Time of STB Edge (.8V to 4V)	$T_{RS}$			100	NS
A/R Width ( $\bar{A}/R$ Connected to STB) *	$T_{ARW}$	1	1.3	2	$\mu s$
STB Width	$T_{SW}$	200			NS
STB Low *	$T_{SL}$				NS
Propagation Delay (STB to $\bar{A}/R$ after $T_{ARW}$ )	$T_{DAR}$			500	NS
A/R Rise Time (Capacitive load = 30pf)	$T_{RAR}$			100	NS
A/R Fall Time (Capacitive load = 30pf)	$T_{FAR}$			100	NS
Time from $\bar{A}/R$ Request to STB Service)	$T_{ARS}$	0		500	$\mu s$
Time of Phoneme Duration *	$T_{PH}$	47	107	250	MS

\* Dependent on Master Clock frequency: 720kHz

\* Strobe must remain low (72x Master Clock Period) before rising edge

Votrax® reserves the right to alter its product line at any time, or change specifications or design without notice and without obligation.

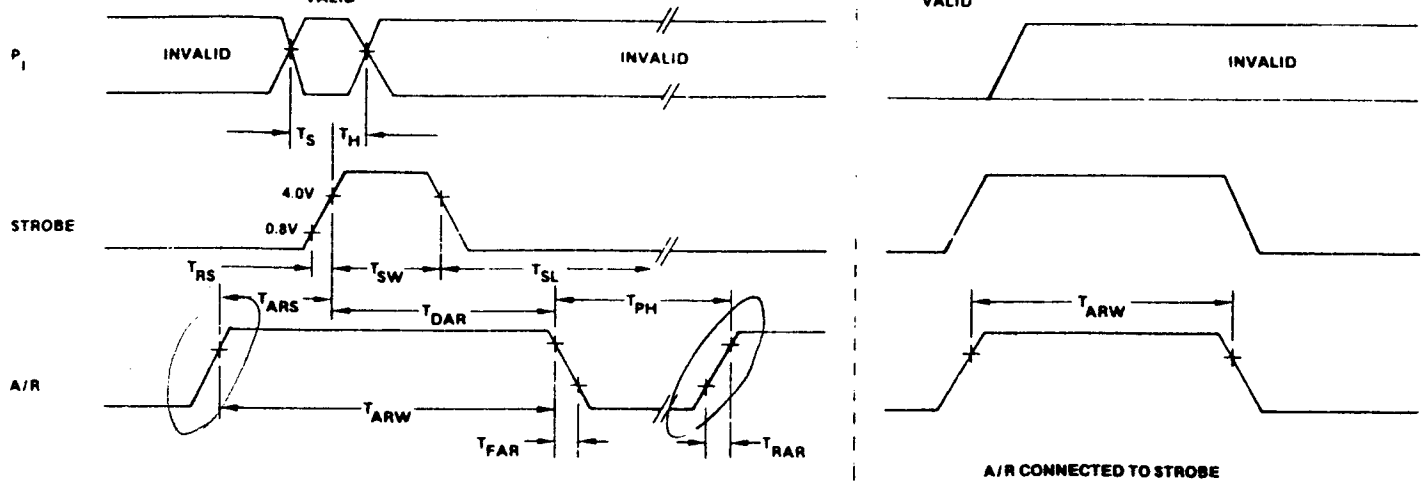

Figure 4. Timing Diagram

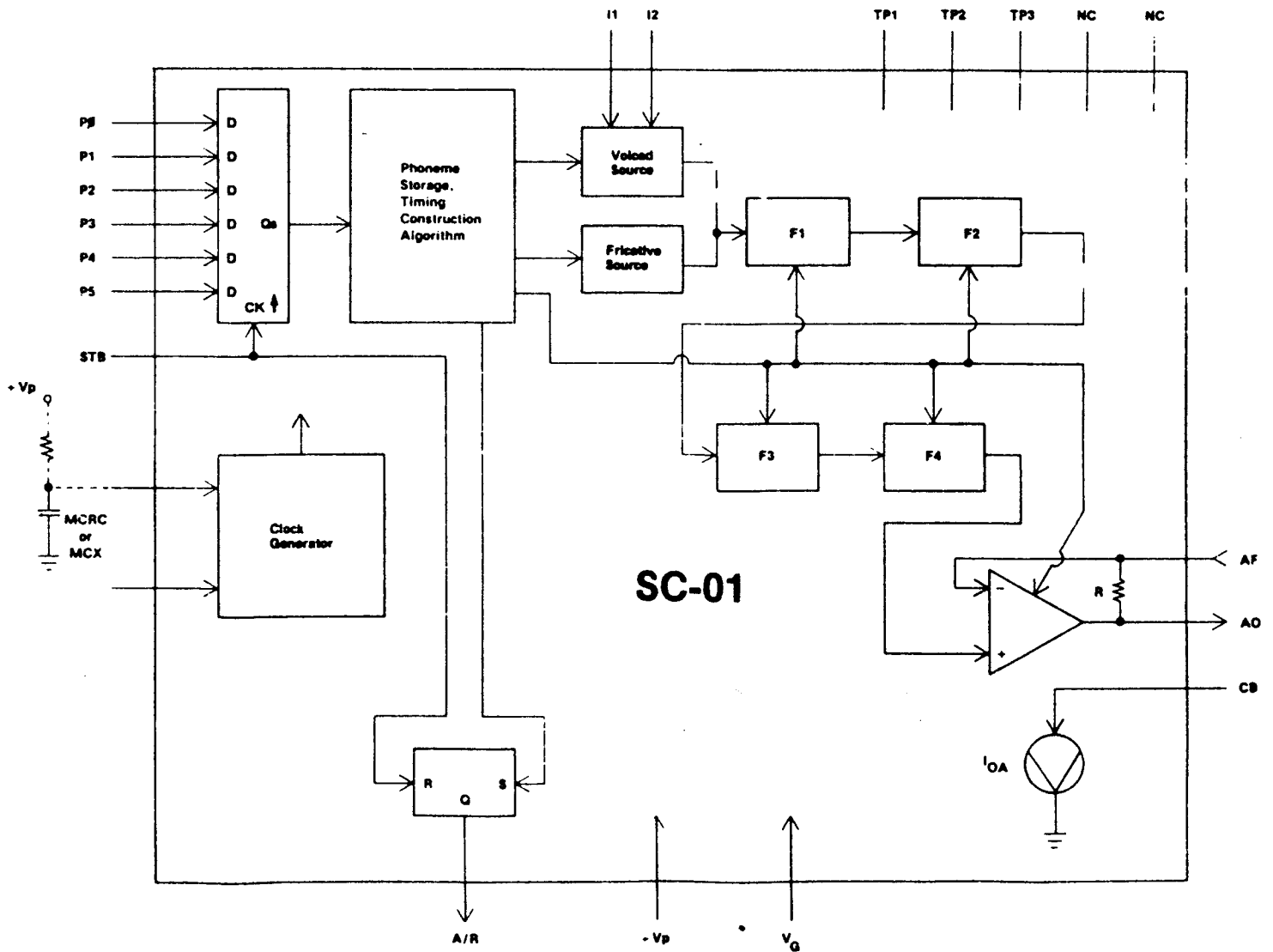

Figure 5. SC-01 Block Diagram

Votrax® reserves the right to alter its product line at any time, or change specifications or design without notice and without obligation.

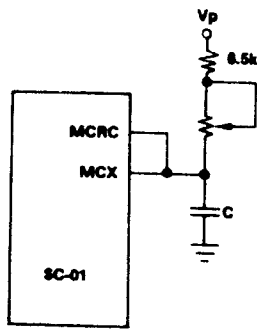

Figure 6. Variable Voice by Potentiometer Control

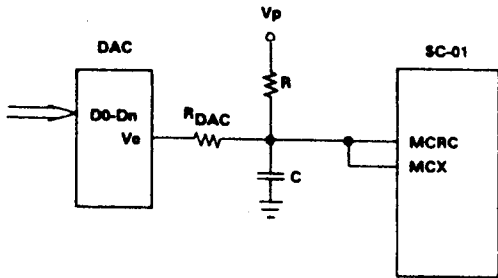

Figure 7. Variable Voice by DAC Current Injection

## TYPICAL APPLICATIONS

**General:** The SC-01 Speech Synthesizer is easily designed into systems ranging in complexity from ROM/counters to microprocessor controllers.

**Single Message System:** See Figure 8. When the counter is released (START is TRUE), the message is clocked out of the ROM by the A/R signal. The system must be stopped when DONE is TRUE. Note: When using A/R tied to STB, connect a .01 uF capacitor to TP3 to insure power up reset of SC-01.

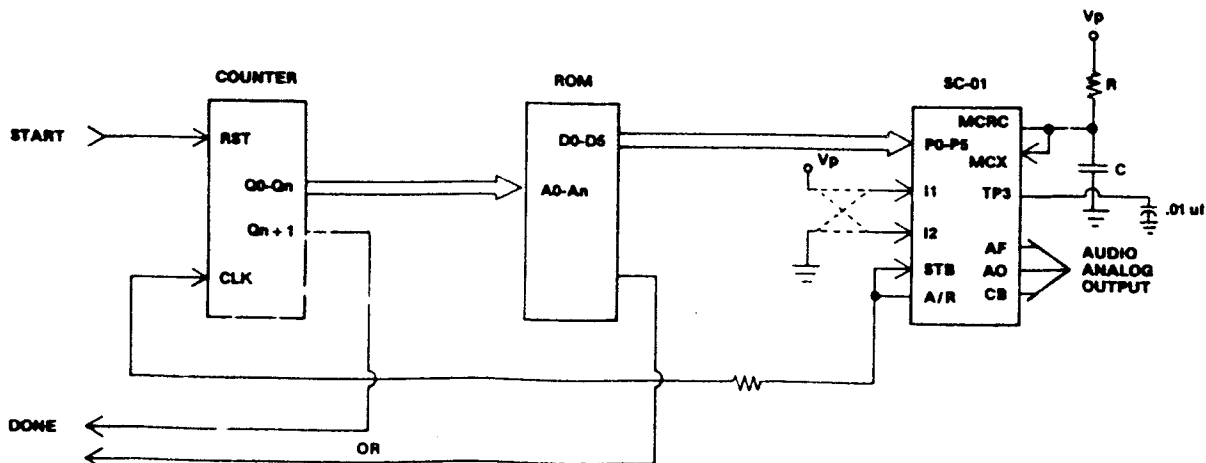

Figure 8. Single Message System

## NOTE

Data at address 0 must be a pause phoneme code.

**Multiple Message, Fixed Block Size:** See Figure 9. Message address block is loaded into the counter. The message is then clocked out of the ROM by the A/R signal.

## NOTE

Message Block =  $2^n$  maximum.

**Multiple Message, Variable Block Size:** See Figure 10. The microprocessor loads phonemes into a data bus. The A/R signal generates an interrupt request for each new phoneme.

## CONNECTING THE AUDIO OUTPUT DEVICE

**Audio Output:** The AO signal has a maximum peak to peak voltage swing of .26 times  $V_p$ , depending upon the phoneme selected, and the AO signal is D.C. biased.

**Class A Amplifier:** See Figure 11. For a single transistor amplifier, the selection of R, C, or  $R_s$  values depends upon the value of  $V_p$  and the desired audio level.

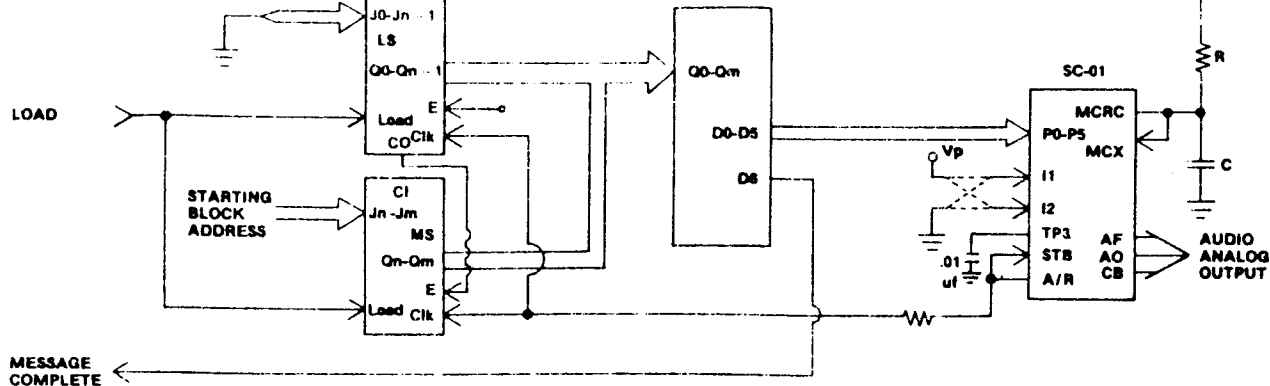

Figure 9. Multiple Message, Fixed Block Size

**Class B Amplifier:** See Figure 12. A current source (CB) is required for this push-pull amplifier.

**NOTE**

Minimum power is consumed when speech is inactive. When  $V_p = +12.0$  volts and  $R_s = 40$  ohms, the bias current drain is approximately 3.5 milliamps.

**Controlling Audio Output Power:** See Figure 13. A resistor or potentiometer from the speaker to ground can be used to control the audio output power.

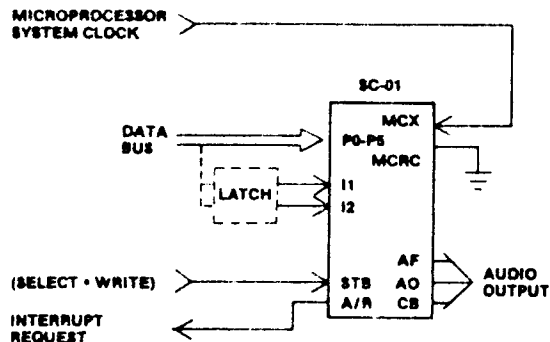

Figure 10. Multiple Message, Variable Block Size

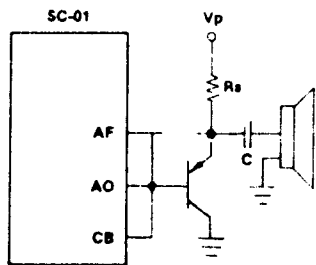

Figure 11. Class A Amplifier

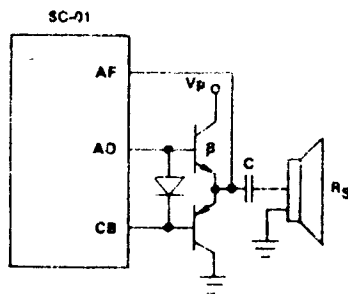

Figure 12. Class B Amplifier \*

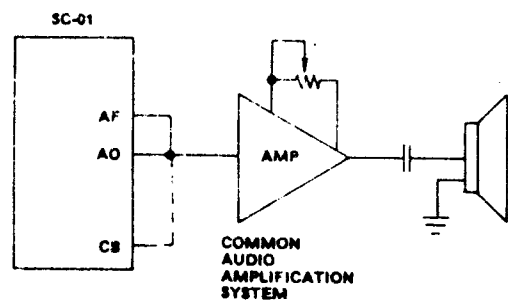

Figure 13. Controlling Audio Output Power

\*For Class B Amplifier:  $(\beta) \times (R_s \text{ min.}) = 81.6 \times (V_p)$  where  $\beta$  is beta or current gain of transistor. The AO line is protected by an internal series current limiting resistor of 90 ohms maximum. If more current is required of the SC-01, then the above formula

CHARACTERISTIC	MIN	MAX	UNIT
Output Voltage (AH Phoneme)	.18 x V <sub>p</sub>	.26 x V <sub>p</sub>	V <sub>p-p</sub>
Output Bias Current ** (.6V < CB < V <sub>p</sub> )	3.5	7.3	mA

**ELECTRICAL CHARACTERISTICS:** T<sub>o</sub> = 0 to 70°C, V<sub>p</sub> = 7 to 14 V<sub>DC</sub>

CHARACTERISTIC	MIN	TYP	MAX	UNIT
Digital Input Impedance	1 meg.			Ohm
Input Capacitance (P <sub>1</sub> , STB)			3	pf
Input Capacitance (I1, I2, MCX)			8	pf
Digital Input Logic "0" (except I1, I2, MCX)	V <sub>G</sub> - 0.5		V <sub>G</sub> + 0.8	V <sub>DC</sub>
Digital Input Logic "0" (MCX)			V <sub>G</sub> + 1.0	V <sub>DC</sub>
Digital Input Logic "0" (I1, I2)			.2 x V <sub>p</sub>	V <sub>DC</sub>
Digital Input Logic "1" (except I1, I2, MCX)	V <sub>G</sub> + 4.0		V <sub>p</sub> + 0.5	V <sub>DC</sub>
Digital Input Logic "1" (I1, I2)	.8 x V <sub>p</sub>			V <sub>DC</sub>
Digital Input Logic "1" (MCX)	4.6			V <sub>DC</sub>
Digital Output Logic "0" (I sink = 0.8mA)			V <sub>G</sub> + 0.5	V <sub>DC</sub>
Digital Output Logic "1" (I source = 0.5mA)	V <sub>p</sub> - 0.5			V <sub>DC</sub>
Power Supply Current	V <sub>p</sub> = 9V	9.1		mA
	V <sub>p</sub> = 9V**	11	18	mA
	V <sub>p</sub> = 14V**	18	27	mA
*Master Clock Frequency		720K		Hz
MCX Input Duty Cycle	60:40		40:60	%
Master Clock Resistor Value (MCRC)***	6.5k			Ohm
Master Clock Capacitor Value (MCRC)***			300	pf

\*Variable

\*\*With CB, AF, AO connected for Class B audio amplifier (see APPLICATION NOTES)

\*\*\*Frequency of Master Clock  $\approx 1.25 / RC$

Note: TP1, TP2 must be left open for normal operation.

Votrax® reserves the right to alter its product line at any time, or change specifications or design without notice and without obligation.



RATING	SYMBOL	VALUE	UNIT
Power Supply Voltage	$V_p$	20	$V_{DC}$
Power Dissipation at 25°C	$P_{DM}$	650	mW
Derating Above 25°C		5	mW °C
Operating Ambient Temperature	$T_o$	0 to 70	°C
Storage Temperature	$T_{STG}$	-55 to 125	°C
Input Voltage	$V_{INM}$	-0.5 to $V_p+0.5$	$V_{DC}$
DC Current Max. Above $V_p+0.5V$	$I_{INM}$	1.0	ma
Lead Temperature (soldering 10 sec.)	$T_L$	300	°C

\* Operation above these limits could damage the device.

NORMAL OPERATING CONDITIONS:  $7v \leq V_p \leq 14v$ ,  $0^\circ C \leq T_o \leq 70^\circ C$

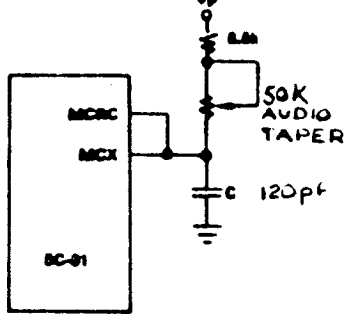

Figure 6. Variable Voice by Potentiometer Control

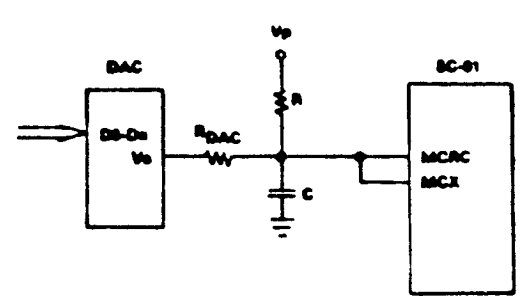

Figure 7. Variable Voice by DAC Current Injection

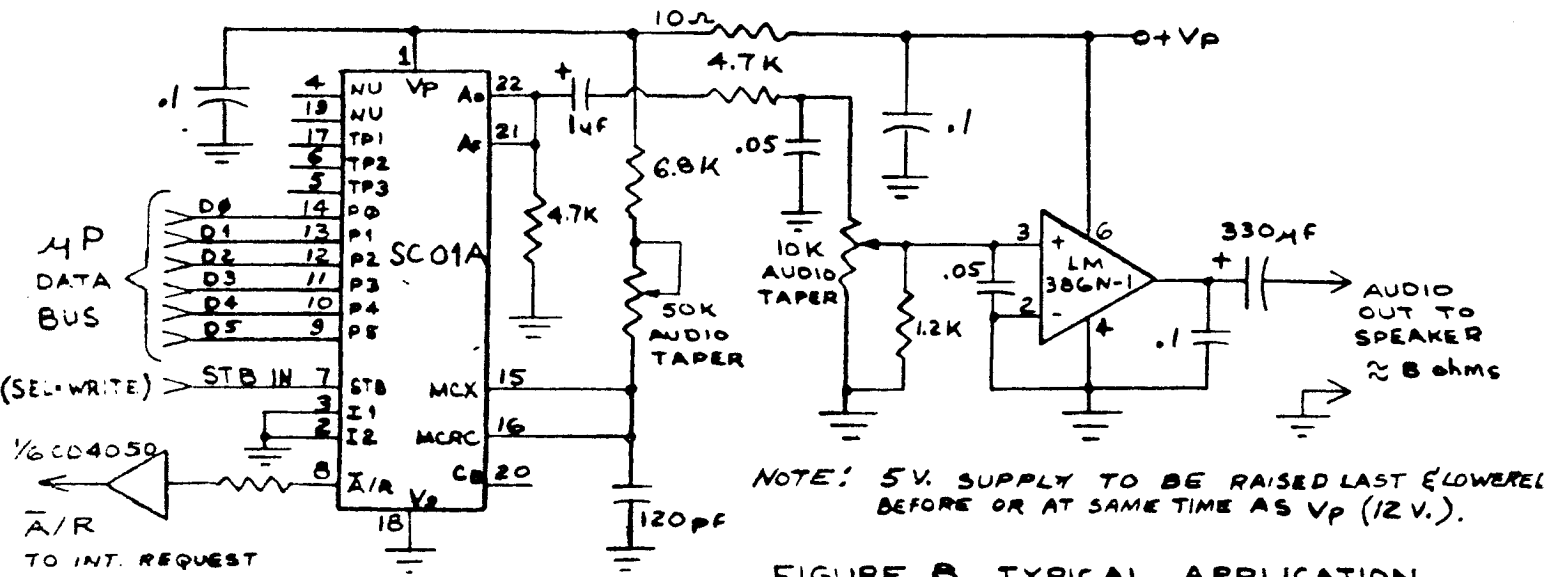

FIGURE 8. TYPICAL APPLICATION

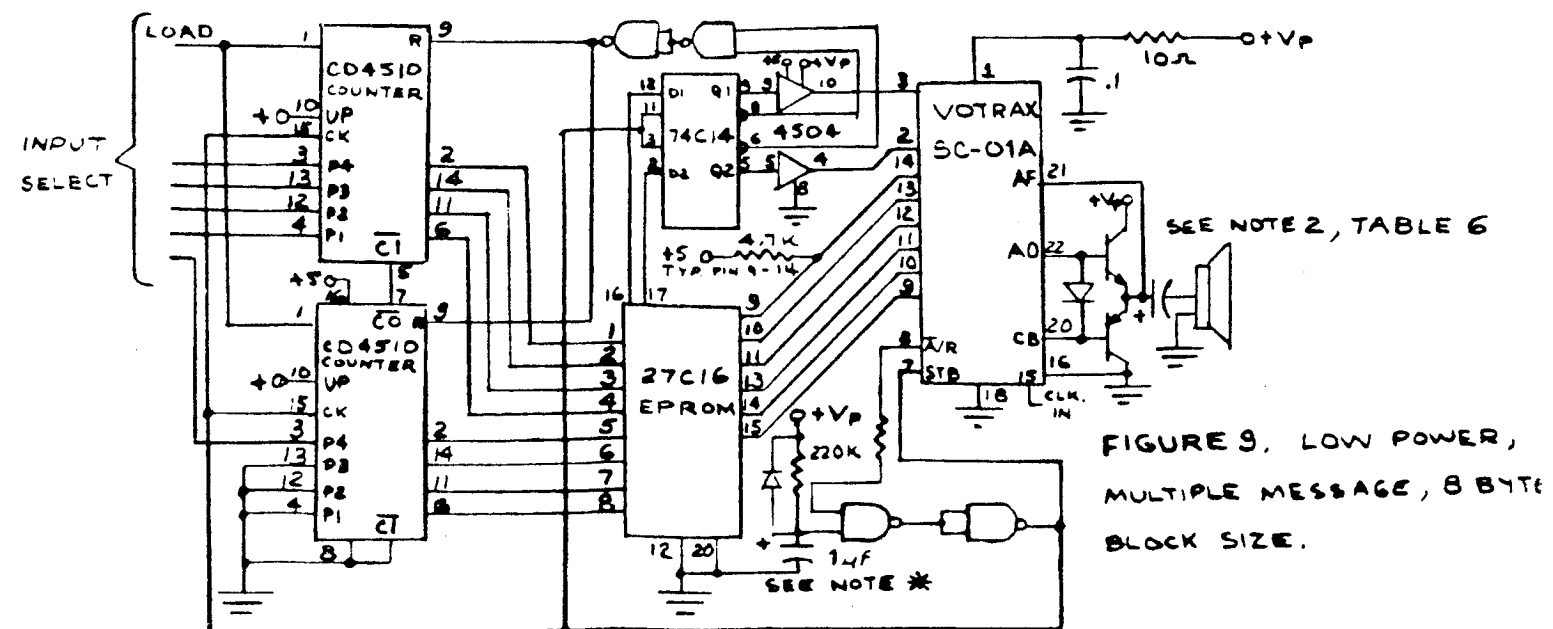

FIGURE 9. LOW POWER, MULTIPLE MESSAGE, 8 BYTE BLOCK SIZE.